



Jersey

MOTOR VEHICLES (CONSTRUCTION AND USE) (JERSEY) ORDER 1998

Official Consolidated Version

This is an official version of consolidated legislation compiled and issued under the authority of the Legislation (Jersey) Law 2021.

Showing the law from 1 January 2025 to 31 December 2025



Jersey

MOTOR VEHICLES (CONSTRUCTION AND USE) (JERSEY) ORDER 1998

Contents

Article

PART 1		10
<hr/>		
PRELIMINARY		10
1	Interpretation	10
2	Application and exemptions.....	25
3	Trade description legislation	27
4	Compliance with Community Directives and ECE Regulations	27
PART 2		28
<hr/>		
THE CONSTRUCTION, EQUIPMENT AND MAINTENANCE OF VEHICLES		28
<i>A – DIMENSIONS AND MANOEUVRABILITY</i>		
5	Length	28
6	Width	31
7	Height	32
8	Indication of overall travelling height	32
9	Overhang	33
10	Minimum ground clearance	34
11	Turning circle – buses	35
12	Turning circle-articulated vehicles other than those incorporating a car transporter	35
13	Turning circle-articulated vehicles incorporating a car transporter	36
14	Connecting sections and direction-holding of articulated buses.....	36
<i>B – BRAKES</i>		
15	Braking systems of certain vehicles first used on or after 1st April 1983	37
16	Braking systems of vehicles to which Article 15 does not apply.....	40
17	Vacuum or pressure brakes warning devices.....	45
18	Maintenance and efficiency of brakes	45
19	Application of brakes of trailers	49
<i>C – WHEELS, SPRINGS, TYRES AND TRACKS</i>		
20	General requirements as to wheels and tracks.....	49

21	Diameter of wheels	49
22	Springs and resilient material	50
23	Wheel loads	50
24	Tyres	51
25	Tyre loads and speed ratings	55
26	Mixing of tyres	60
27	Condition and maintenance of tyres	62
28	Tracks	64
<i>D – STEERING</i>		
29	Maintenance of steering gear	64
<i>E – VISION</i>		
30	View to the front	65
31	Glass to be fitted to certain vehicles	65
32	Glass to be fitted to other vehicles	66
33	Mirrors	70
34	Windscreen wipers and washers	75
<i>F – INSTRUMENTS AND EQUIPMENT</i>		
35	Speedometers	76
36	Maintenance of speedometers	76
37	Audible warning instruments	77
38	Motor cycle sidestands	78
<i>G – FUEL</i>		
39	Fuel tanks	78
40	Vehicles designed and constructed to run on unleaded petrol	79
41	Dimension of fuel tanks for purposes of filling	79
42	Gas propulsion systems and gas-fired appliances	80
<i>H – MINIBUSES</i>		
43	Minibuses	80
44	Fire extinguishing apparatus	80
45	First aid equipment	81
46	Carriage of dangerous substances	81
<i>I – POWER TO WEIGHT RATIO</i>		
47	Power to weight ratio	81
<i>J – PROTECTIVE SYSTEMS</i>		
48	Seat belt anchorage points	82
49	Seat belts	85
50	Maintenance of seat belts and anchorage points	90
51	Minibuses and coaches to be fitted with additional seat belts when used in certain circumstances	91
52	Rear under-run protection	93
53	Maintenance of rear under-run protective device	95
54	Sideguards	95
55	Maintenance of sideguards	100

56	Mascots, ornamental objects, etc.	100
57	Strength of superstructure	100
58	Additional exits from double-decked coaches	100

K – CONTROL OF EMISSIONS

59	Silencers – general	101
60	Noise limits – general	102
61	Noise limits – agricultural motor vehicles and industrial tractors	105
62	Noise limits – motor cycles construction requirements	105
63	Exhaust systems – motor cycles	106
64	Noise limits – maintenance requirements relating to motor cycles	108
65	Noise limits – vehicles not subject to Articles 60 to 62 first used on or after 1st April 1970	109
66	Exceptions to Articles 60 and 65	111
67	Radio interference suppression	111
68	Emission of smoke, vapour, gases, oily substances, etc.	111
69	Closets etc.	124
70	Wings	124
71	Spray suppression devices	125
72	Maintenance of spray suppression devices	126

PART 3 **127**

PLATES AND MARKINGS **127**

73	Plates for goods vehicles and buses	127
74	Vehicle identification number	129
75	Plates – agricultural trailed appliances	130
76	Plates – motor cycles and mopeds	130
77	Department plates	130
78	Marking of weights on certain vehicles	131
79	Additional markings	131
80	Test date discs	131

PART 4 **132**

CONDITIONS RELATING TO USE **132**

A – LADEN WEIGHT

81	Maximum permitted laden weight of a vehicle	132
82	Maximum permitted laden weight of a vehicle and trailer, other than an articulated vehicle	135
83	Maximum permitted laden weight of an articulated vehicle	136
84	Maximum permitted wheel and axle weights	137
85	Maximum permitted weights for certain closely-spaced axles etc.	139
86	Over-riding weight restrictions	140

B – DIMENSIONS OF LADEN VEHICLES

87	Interpretation for the purposes of Articles 87, 88 and Schedule 14	140
88	Restrictions on use of vehicles carrying wide or long loads or having fixed appliances or apparatus	142

C – TRAILERS AND SIDECAR

89	Number of trailers	145
90	Trailers drawn by motor cycles	146
91	Trailers drawn by agricultural motor vehicles.....	146
92	Distance between motor vehicles and trailers.....	147
93	Use of secondary coupling on trailers	147
94	Unbraked trailers.....	148
95	Use of bridging plates between motor vehicle and trailer	148
96	Leaving trailers at rest	148
97	Passengers in trailer	149
98	Attachment of sidecars.....	149
99	Use of sidecars.....	149

D – USE OF GAS PROPULSION SYSTEMS AND GAS-FIRED APPLIANCES

100	Use of gas propulsion systems	149
101	Use of gas-fired appliances – general.....	150
102	Use of gas-fired appliances when a vehicle is in motion	150

E – CONTROL OF NOISE

103	Avoidance of excessive noise	151
104	Stopping of engine when stationary	152
105	Use of audible warning instruments	152

F – AVOIDANCE OF DANGER

106	Maintenance and use of vehicle so as not to be a danger, etc.....	153
107	Restricted speed.....	154
108	Parking in darkness.....	154
109	Passengers on motor cycles	155
110	Obstruction of emergency vehicles.....	155
111	Driver’s control	155
112	Opening of doors.....	155
113	Reversing	155
114	Leaving motor vehicles unattended.....	155
115	Securing of suspended implements	156
116	Television sets.....	156

PART 5 156**TESTING OF VEHICLES ETC 156**

117	Testing of vehicles	156
118	Defect notice	157
119	Impounding of vehicles	158
120	Power to require certificates of compliance.....	158
120A	Annual examination and certificate of compliance for certain goods vehicles and trailers used for business.....	159
121	Lost or defaced certificate of compliance	160

PART 6 161**MISCELLANEOUS AND GENERAL 161**

122	Citation	161
SCHEDULE 1		162
COMMUNITY DIRECTIVES AND ECE REGULATIONS		162
SCHEDULE 2		171
BRAKING REQUIREMENTS		171
SCHEDULE 3		175
EXCLUSION OF CERTAIN VEHICLES FROM THE APPLICATION OF ARTICLE 40		175
PART 1		175
PART 2		176
Symbol indicating that vehicle can run on unleaded petrol		176
SCHEDULE 4		177
GAS CONTAINERS		177
PART 1		177
1	Definitions relating to gas containers	177
2	Gas containers	177
3	Pipe lines	177
4	Unions	178
5	Reducing valves	178
6	Valves and cocks	178
7	Pressure gauges	178
8	Charging connections	179
9	Trailers	179
10	Construction, etc. of system	179
PART 2		180
1	Manufacture of valves	180
2	Heat treatment	180
3	Freedom from defects	180
4	Tensile test	180
SCHEDULE 5		181
GAS SYSTEMS		181
1	Definitions	181
2	Gas containers	182
3	Filling systems for fixed gas containers	182
4	Pipelines	183
5	Unions and joints	184
6	Reducing valves	184
7	Pressure relief valves	184
8	Valves and cocks	185
9	Gauges	185

10	Propulsion systems.....	186
11	Special requirements for buses.....	186
12	Gas-fired appliances.....	186
13	186
14	187
15	General requirements.....	187
SCHEDULE 6		188
CONSTRUCTION OF MINIBUSES		188
1	Exhaust pipes.....	188
2	Doors – number and position.....	188
3	Emergency doors.....	188
4	Power-operated doors.....	188
5	Locks, handles and hinges of doors.....	189
6	View of doors.....	190
7	Access to doors.....	190
8	Grab handles and hand rails.....	190
9	Seats.....	190
10	Electrical equipment and wiring.....	191
11	Fuel tanks.....	191
12	Lighting of steps.....	192
13	General construction and maintenance.....	192
14	Definitions.....	192
SCHEDULE 7		193
FIRE EXTINGUISHING APPARATUS AND FIRST AID EQUIPMENT FOR MINIBUSES		193
PART 1		193
Fire extinguishing apparatus.....		193
PART 2		193
First aid equipment.....		193
SCHEDULE 8		194
MOTOR CYCLE NOISE AND MOTOR CYCLE SILENCERS		194
PART 1		194
PART 2		195
PART 3		195
SCHEDULE 9		197
EMISSIONS FROM CERTAIN MOTOR VEHICLES		197
PART 1		197
Vehicles propelled by spark ignition engines.....		197
PART 2		198
Vehicles propelled by compression ignition engines.....		198

SCHEDULE 10	199
<hr/>	
PLATES FOR CERTAIN VEHICLES	199
PART 1	199
PART 2	199
PART 3	200
SCHEDULE 11	203
<hr/>	
Plates for motor cycles and mopeds.....	203
Diagram of Plate.....	203
SCHEDULE 12	206
<hr/>	
DEPARTMENT PLATE	206
SCHEDULE 13	207
<hr/>	
MAXIMUM PERMITTED WEIGHTS, ETC.	207
PART 1	207
PART 2	208
PART 3	209
PART 4	209
PART 5	210
PART 6	211
PART 7	212
SCHEDULE 14	213
<hr/>	
CONDITIONS TO BE COMPLIED WITH IN RELATION TO THE USE OF VEHICLES CARRYING WIDE OR LONG LOADS OR VEHICLES CARRYING LOADS OR HAVING FIXED APPLIANCES OR APPARATUS WHICH PROJECT	213
PART 1	213
1 Advance notice to highway authority	213
2 Attendance	214
3 Marking of longer projections	214
4 Marking of shorter projections	215
5 Marking of wide loads	215
PART 2	216
PROJECTION MARKERS	216
Diagram of end marker surface	216
Diagram of side marker surface	217
SCHEDULE 15	218
<hr/>	
PLATE FOR RESTRICTED SPEED VEHICLE	218

ENDNOTES	219
Table of Legislation History.....	219
Table of Renumbered Provisions	221
Table of Endnote References.....	222



Jersey

MOTOR VEHICLES (CONSTRUCTION AND USE) (JERSEY) ORDER 1998¹

THE HOME AFFAIRS COMMITTEE, in pursuance of Articles 77 and 84 of the [Road Traffic \(Jersey\) Law 1956](#), orders as follows –

Commencement [[see endnotes](#)]

PART 1

PRELIMINARY

1 Interpretation

(1) In this Order, unless the context otherwise requires –

“1935 Law” means the [Motor Traffic \(Jersey\) Law 1935](#);

“1993 Law” means the [Motor Vehicle Registration \(Jersey\) Law 1993](#);

“Act of Accession” means the Treaty concerning the Accession of the Kingdom of Denmark, Iceland, the Kingdom of Norway and the United Kingdom of Great Britain and Northern Ireland to the European Economic Community and the European Atomic Energy Community;

“agricultural motor vehicle” means a motor vehicle which is constructed or adapted for use off roads for the purpose of agriculture, horticulture or forestry and which is primarily used for one or more of those purposes, not being a dual-purpose vehicle;

“agricultural trailed appliance” means a trailer –

(a) which is an implement constructed or adapted –

(i) for use off roads for the purpose of agriculture, horticulture or forestry and which is only used for one or more of those purposes, and

(ii) so that, save in the case of an appliance manufactured before 1st December 1985, or a towed roller, its maximum gross weight is not more than twice its unladen weight; but

(b) which is not –

- (i) a vehicle which is used primarily as living accommodation by one or more persons, and which carries no goods or burden except those needed by such one or more persons for the purpose of their residence in the vehicle, or
- (ii) an agricultural, horticultural or forestry implement rigidly but not permanently mounted on any vehicle whether or not any of the weight of the implement is supported by one or more of its own wheels; so however that such an implement is an agricultural trailed appliance if –
 - (A) part of the weight of the implement is supported by one or more of its own wheels; and
 - (B) the longitudinal axis of the greater part of the implement is capable of articulating in the horizontal plane in relation to the longitudinal axis of the rear portion of the vehicle on which it is mounted;

“agricultural trailed appliance conveyor” means an agricultural trailer which –

- (a) has an unladen weight which does not exceed 510 kg;
- (b) is clearly and indelibly marked with its unladen weight;
- (c) has a pneumatic tyre fitted to each one of its wheels;
- (d) is designed and constructed for the purpose of conveying one agricultural trailed appliance or one agricultural, horticultural or forestry implement;

“agricultural trailer” means a trailer which is constructed or adapted for the purpose of agriculture, horticulture or forestry and which is only used for one or more of those purposes, not being an agricultural trailed appliance;

“Approval Marks Regulations” means the Motor Vehicles (Designation of Approval Marks) Regulations 1979 of the United Kingdom;

“articulated bus” means a bus so constructed that –

- (a) it can be divided into 2 parts, both of which are vehicles and one of which is a motor vehicle, but cannot be so divided without the use of facilities normally available only at a workshop; and
- (b) passengers carried by it can at all times pass from either part to the other;

“articulated vehicle” means a heavy motor car or motor car, not being an articulated bus, with a trailer so attached that part of the trailer is superimposed on the drawing vehicle and, when the trailer is uniformly loaded, not less than 20% of the weight of its load is borne by the drawing vehicle;

“axle” and the “number of axles on a vehicle” shall be interpreted in accordance with paragraph (9);

“axle weight”, in relation to each axle of a vehicle, means the sum of the weights transmitted to the road surface by all the wheels of that axle, having regard to the provisions of paragraph (9);

“braking efficiency” means the maximum braking force capable of being developed by the brakes of a vehicle, expressed as a percentage of the weight of the vehicle including any persons or load carried in the vehicle;

“braking system” shall be interpreted in accordance with paragraph (7);

“bus” means a motor vehicle which is constructed or adapted to carry more than 8 seated passengers in addition to the driver;

“car transporter” means a trailer which is constructed and normally used for the purpose of carrying at least 2 other wheeled vehicles;

“cc” means cubic centimetres;

“close-coupled”, in relation to wheels on the same side of a trailer, means fitted so that at all times while the trailer is in motion they remain parallel to the longitudinal axis of the trailer, and the distance between the centres of their respective areas of contact with the road surface does not exceed 1 m;

“cm” means centimetres;

“cm²” means square centimetres;

“coach” means a large bus with a maximum gross weight of more than 7.5 tonnes and with a maximum speed exceeding 60 mph;

“Community Directive”, followed by a number, means the Directive adopted by the Council or the Commission of the European Communities of which identifying particulars are given in the item in column 3 of Table 1 in Schedule 1 in which that number appears in column 2; where such a Directive amends a previous Directive mentioned in column 3(d) of the Table the reference to the amending Directive includes a reference to that previous Directive as so amended; any reference to a Directive which has been amended by the Act of Accession is a reference to the Directive as so amended;

“composite trailer” means a combination of a converter dolly and a semi-trailer;

“container” means an article of equipment, not being a motor vehicle or trailer, having a volume of at least 8 cubic metres, constructed wholly or mostly of metal and intended for repeated use for the carriage of goods or burden;

“converter dolly” means –

- (a) a trailer which is –
 - (i) equipped with 2 or more wheels,
 - (ii) designed to be used in combination with a semi-trailer without any part of the weight of the semi-trailer being borne by the drawing vehicle, and
 - (iii) not itself a part either of the semi-trailer or the drawing vehicle when being so used; or
- (b) a trailer which is –
 - (i) equipped with 2 or more wheels,
 - (ii) designed to be used in combination with a semi-trailer with part of the weight of the semi-trailer being borne by the drawing vehicle,
 - (iii) not itself a part either of the semi-trailer of the drawing vehicle when being so used, and
 - (iv) used solely for the purposes of agriculture, horticulture or forestry, or for any 2 or for all of those purposes;

“Council Regulation (EEC)”, followed by a number, means the Regulation adopted by the Council of the European Communities;

“deck” means a floor or platform on which seats are provided for the accommodation of passengers;

“Departmental plate” means a plate required to be fixed to every goods vehicle by virtue of Article 77 and in the form in and containing the particulars required by Schedule 12;

“design weight” in relation to the gross weight, each axle weight or the train weight of a motor vehicle or trailer, means the weight at or below which, in the opinion of the Secretary of State for Transport of the United Kingdom or of a person authorized in that behalf by the Secretary of State for Transport of the United Kingdom or the Inspector of Motor Traffic, the vehicle could safely be driven on a road;

“double-decked vehicle” means a vehicle having 2 decks one of which is wholly or partly above the other and each of which is provided with a gangway serving seats on that deck only;

“dual-purpose vehicle” means a vehicle constructed or adapted for the carriage both of passengers and of goods or burden of any description, being a vehicle of which the unladen weight does not exceed 2,040 kg and which either –

- (a) is so constructed or adapted that the driving power of the engine is, or by the appropriate use of the controls of the vehicle can be, transmitted to all the wheels of the vehicle; or
- (b) satisfies the following conditions as to construction, namely –
 - (i) the vehicle must be permanently fitted with a rigid roof, with or without a sliding panel,
 - (ii) the area of the vehicle to the rear of the driver’s seat must –
 - (A) be permanently fitted with at least one row of transverse seats (fixed or folding) for 2 or more passengers and those seats must be properly sprung or cushioned and provided with upholstered back-rests, attached either to the seats or to a side or the floor of the vehicle, and
 - (B) be lit on each side and at the rear by a window or windows of glass or other transparent material having an area or aggregate area of not less than 1,850 square centimetres on each side and not less than 770 square centimetres at the rear, and
 - (iii) the distance between the rearmost part of the steering wheel and the back-rests of the row of transverse seats satisfying the requirements specified in clause (ii)(A) (or, if there is more than one such row of seats, the distance between the rearmost part of the steering wheel and the back-rests of the rearmost such row) must, when the seats are ready for use, be not less than one-third of the distance between the rearmost part of the steering wheel and the rearmost part of the floor of the vehicle;

“ECE Regulation”, followed by a number, means the Regulation annexed to the Agreement concerning the adoption of uniform conditions of approval for Motor Vehicles Equipment and Parts and reciprocal recognition thereof concluded at Geneva on 20th March 1958, as amended, to which the United Kingdom is a party, of which identifying particulars are given in the item in column (3)(a), (b) and (c) of Table 2 in Schedule 1 in which that number appears in column (2), and where

that number contains more than 2 digits, it refers to that Regulation with the amendments in force at the date specified in column (3)(d) in that item;

“engine power in kilowatts (KW)” means the maximum net power ascertained in accordance with Community Directive 80/1269;

“engineering equipment” means engineering plant and any other plant or equipment designed and constructed for the purpose of engineering operations;

“engineering plant” means –

- (a) movable plant or equipment being a motor vehicle or trailer specially designed and constructed for the special purposes of engineering operations, and which cannot, owing to the requirements of those purposes, comply with all the requirements of this Order and which is not constructed primarily to carry a load other than a load being either excavated materials raised from the ground by apparatus on the motor vehicle or trailer or materials which the vehicle or trailer is specially designed to treat while carried thereon; or
- (b) a mobile crane which does not comply in all respects with the requirements of this Order;

“exhaust system” means a complete set of components through which the exhaust gases escape from the engine unit of a motor vehicle including those which are necessary to limit the noise caused by the escape of those gases;

“first used” shall be interpreted in accordance with paragraph (4);

“gangway” means the space provided for obtaining access from any entrance to the passengers’ seats or from any such seat to an exit other than an emergency exit, but excluding a staircase and any space in front of a seat which is required only for the use of passengers occupying that seat or a seat in the same row of seats;

“gas” means any fuel which is wholly gaseous at 17.5°C under a pressure of 1.013 bar absolute;

“gas-fired appliance” means a device carried on a motor vehicle or trailer when in use on a road, which consumes gas and which is neither –

- (a) a device owned or operated by or with the authority of the Jersey Gas Company Limited for the purpose of detecting gas;
- (b) an engine for the propulsion of a motor vehicle; nor
- (c) a lamp which consumes acetylene gas;

“gritting trailer” means a trailer which is used on a road for the purposes of spreading grit or other matter so as to avoid or reduce the effect of ice or snow on the road;

“gross weight” means –

- (a) in relation to a motor vehicle, the sum of the weights transmitted to the road surface by all the wheels of the vehicle;
- (b) in relation to a trailer, the sum of the weights transmitted to the road surface by all the wheels of the trailer and of any weight of the trailer imposed on the drawing vehicle;

“home force” has the meaning given by Article 3(1) of the [Armed Forces \(Offences and Jurisdiction\) \(Jersey\) Law 2017](#);

“indivisible load” means a load which cannot, without undue expense or risk of damage, be divided into 2 or more loads for the purpose of conveyance on a road;

“industrial tractor” means a tractor, not being an agricultural motor vehicle, which –

- (a) has an unladen weight not exceeding 7,370 kg;
- (b) is designed and used primarily for work off roads, or for work on roads in connection only with road construction or maintenance (including any such tractor when fitted with an implement or implements designed primarily for use in connection with such work, whether or not any such implement is of itself designed to carry a load; and
- (c) has a maximum speed not exceeding 20 mph;

“kg” means kilograms;

“km/h” means kilometres per hour;

“kW” means kilowatts;

“large bus” means a vehicle constructed or adapted to carry more than 16 seated passengers in addition to the driver;

“Law” means the [Road Traffic \(Jersey\) Law 1956](#);

“light trailer” means a trailer with a maximum gross weight which does not exceed 3,500 kg;

“Lighting Order” means the [Road Traffic \(Lighting\) \(Jersey\) Order 1998](#);

“living van” means a vehicle used primarily as living accommodation by one or more persons, and which is not also used for the carriage of goods or burden which are not needed by such one or more persons for the purpose of their residence in the vehicle;

“longitudinal plane” means a vertical plane parallel to the longitudinal axis of a vehicle;

“low loader” means a semi-trailer, not being a stepframe low loader, which is constructed and normally used for the carriage of engineering equipment so constructed that the major part of the load platform does not extend over or between the wheels and the upper surface of which is below the height of the topmost point of the tyres of those wheels, measured on level ground and when –

- (a) any adjustable suspension is at the normal travelling height;
- (b) all pneumatic tyres are suitably inflated for use when the vehicle is fully laden; and
- (c) the semi-trailer is unladen;

“low platform trailer” means a trailer fitted with tyres with a rim diameter size code of less than 20 and displaying a rectangular plate which –

- (a) is at least 225 mm wide and at least 175 mm high; and
- (b) bears 2 black letters “L” on a white ground each at least 125 mm high and 90 mm wide with a stroke width of 12 mm;

“m” means metres;

“m²” means square metres;

“m³” means cubic metres;

“maximum permitted axle weight” means, in relation to an axle –

- (a) in the case of a vehicle which is equipped with a plate in accordance with Article 73, the maximum axle weight shown for that axle on the plate in respect of item 6 of Part 1 of Schedule 10 in the case of a motor vehicle and item 4 of Part 2 of Schedule 10 in the case of a trailer; and
- (b) in any other case, the weight which the axle is designed or adapted not to exceed when the vehicle is travelling on a road;

“maximum gross weight” means –

- (a) in the case of a vehicle equipped with a Department Plate in accordance with Article 77, the maximum gross weight shown at item 3 of that plate where the plate is in the form required by Schedule 12;
- (b) in the case of a vehicle which is equipped with a plate in accordance with Article 73, the maximum gross weight shown on the plate in respect of item 7 of Part 1 of Schedule 10 in the case of a motor vehicle and item 6 of Part 2 of Schedule 10 in the case of a trailer;
- (c) in any other case, the weight which the vehicle is designed or adapted not to exceed when the vehicle is travelling on a road;

“maximum speed” means the speed which a vehicle is incapable, by reason of its construction, of exceeding on the level under its own power when fully laden;

“maximum total design axle weight” (being an expression used only in relation to trailers) means –

- (a) in the case of a trailer equipped with a plate in accordance with Article 73, the sum of the maximum axle weights shown on the plate in respect of item 4 of Part 2 of Schedule 10; or
- (b) in the case of any other trailer, the sum of the axle weights which the trailer is designed or adapted not to exceed when the vehicle is travelling on a road;

“Minister” means, except in Article 74(2)(c)(ii), the Minister for Infrastructure;

“mm” means millimetres;

“motor ambulance” means a motor vehicle which is specially designed and constructed (and not merely adapted) for carrying, as equipment permanently fixed to the vehicle, equipment used for medical, dental, or other health purposes and is used primarily for the carriage of persons suffering from illness, injury or disability;

“motor caravan” means a motor vehicle which is constructed or adapted for the carriage of passengers and their effects and which contains as permanently installed equipment, the facilities which are reasonably necessary for enabling the vehicle to provide mobile living accommodation for its users;

“motor cycle” means a heavy motor cycle or a light motor cycle or a moped;

“mph” means miles per hour;

“N/mm²” means newtons per square millimetre;

“off-road vehicle” means an off-road vehicle defined in Annex 1 to Council Directive 70/156/EEC of 6th February 1970 as read with Council Directive 87/403/EEC of 25th June 1987;

“overall height” means the vertical distance between the ground and the point on the vehicle which is furthest from the ground, calculated when –

- (a) the tyres of the vehicle are suitably inflated for the use to which it is being put;
- (b) the vehicle is at its unladen weight; and
- (c) the surface of the ground under the vehicle is reasonably flat,

but, in the case of a trolley bus, exclusive of the power collection equipment mounted on the roof of the vehicle;

“overall length”, in relation to a vehicle, means the distance between transverse planes passing through the extreme forward and rearward projecting points of the vehicle inclusive of all parts of the vehicle, of any receptacle which is of a permanent character and accordingly strong enough for repeated use, and any fitting on, or attached to, the vehicle except –

- (a) for all purposes –
 - (i) any driving mirror,
 - (ii) any expanding or extensible contrivance forming part of a turntable fire escape fixed to a vehicle,
 - (iii) any snow-plough fixed in front of a vehicle,
 - (iv) any receptacle specially designed to hold and keep secure a seal issued for the purpose of customs clearance,
 - (v) any tailboard which is let down while the vehicle is stationary in order to facilitate its loading or unloading,
 - (vi) any tailboard which is let down in order to facilitate the carriage of, but which is not essential for the support of, loads which are in themselves so long as to extend at least as far as the tailboard when upright,
 - (vii) any fitting attached to a part of, or to a receptacle on, a vehicle which does not increase the carrying capacity of the part or receptacle but which enables it to be –
 - (A) transferred from a road vehicle to a railway vehicle or from a railway vehicle to a road vehicle,
 - (B) secured to a railway vehicle by a locking device, and
 - (C) carried on a railway vehicle by the use of stanchions,
 - (viii) any plate, whether rigid or movable, fitted to a trailer constructed for the purpose of carrying other vehicles and designed to bridge the gap between that trailer and a motor vehicle constructed for that purpose and to which the trailer is attached so that, while the trailer is attached to the motor vehicle, vehicles which are to be carried by the motor vehicle may be moved from the trailer to the motor vehicle before a journey begins, and vehicles which have been carried on the motor vehicle may be moved from it to the trailer after a journey ends,

- (ix) any sheeting or other readily flexible means of covering or securing a load,
 - (x) any receptacle with an external length, measured parallel to the longitudinal axis of the vehicle, not exceeding 2.5 m,
 - (xi) any empty receptacle which itself forms a load,
 - (xii) any empty receptacle which contains an indivisible load of exceptional length,
 - (xiii) any receptacle manufactured before 30th October 1985, not being a maritime container (namely a container designed primarily for carriage on sea transport without an accompanying road vehicle),
 - (xiv) any special appliance or apparatus described in Article 87(c) which does not itself increase the carrying capacity of the vehicle, or
 - (xv) any rearward projecting buffer made of rubber or other resilient material;
- (b) for the purpose of Articles 5 and 12 –
- (i) any part of a trailer (not being in the case of an agricultural trailed appliance a drawbar or other thing with which it is equipped for the purpose of being towed) designed primarily for use as a means of attaching it to another vehicle and any fitting designed for use in connection with any such part,
 - (ii) the thickness of any front or rear wall on a semi-trailer and of any part forward of such front wall or rearward of such rear wall which does not increase the vehicle's load-carrying space;

“overall width” means the distance between longitudinal planes passing through the extreme lateral projecting points of the vehicle inclusive of all parts of the vehicle, of any receptacle which is of permanent character and accordingly strong enough for repeated use, and any fitting on, or attached to, the vehicle except –

- (a) any driving mirror;
- (b) any snow-plough fixed in front of the vehicle;
- (c) so much of the distortion of any tyre as is caused by the weight of the vehicle;
- (d) any receptacle specially designed to hold and keep secure a seal issued for the purposes of customs clearance;
- (e) any lamp or reflector fitted to the vehicle in accordance with the Lighting Order;
- (f) any sideboard which is let down while the vehicle is stationary in order to facilitate its loading or unloading;
- (g) any fitting attached to part of, or to a receptacle on, a vehicle which does not increase the carrying capacity of the part or receptacle but which enables it to be –
 - (i) transferred from a road vehicle to a railway vehicle or from a railway vehicle to a road vehicle,
 - (ii) secured to a railway vehicle by a locking device, and

- (iii) carried on a railway vehicle by the use of stanchions; and
- (h) any sheeting or other readily flexible means of covering or securing a load;
- (i) any receptacle with an external width, measured at right angles to the longitudinal axis of the vehicle, which does not exceed 2.3 m;
- (j) any empty receptacle which itself forms a load;
- (k) any receptacle which contains an indivisible load of exceptional width;
- (l) any receptacle manufactured before 30th October 1985, not being a maritime container (namely a container designed primarily for carriage on sea transport without an accompanying road vehicle); or
- (m) any special appliance or apparatus as described in Article 87(c) which does not itself increase the carrying capacity of the vehicle;

“overhang” means the distance measured horizontally and parallel to the longitudinal axis of a vehicle between transverse planes passing through the following 2 points –

- (a) the rearmost point of the vehicle exclusive of –
 - (i) any expanding or extensible contrivance forming part of a turntable fire escape fixed to a vehicle,
 - (ii) in the case of a motor car constructed solely for the carriage of passengers and their effects and adapted to carry not more than 8 passengers exclusive of the driver, any luggage carrier fitted to the vehicle; and
- (b)
 - (i) in the case of a motor vehicle having not more than 3 axles of which only one is not a steering axle, the centre point of that axle,
 - (ii) in the case of a motor vehicle having 3 axles of which the front axle is the only steering axle and of a motor vehicle having 4 axles of which the 2 foremost are the only steering axles, a point 110 mm behind the centre of a straight line joining the centre points of the 2 rearmost axles, and
 - (iii) in any other case a point situated on the longitudinal axis of the vehicle and such that a line drawn from it at right angles to that axis will pass through the centre of the minimum turning circle of the vehicle;

“passenger vehicle” means a vehicle constructed solely for the carriage of passengers and their effects;

“Plating and Testing Regulations” means the Goods Vehicles (Plating and Testing) Regulations 1982 of the United Kingdom;

“pneumatic tyre” means a tyre which –

- (a) is provided with, or together with the wheel upon which it is mounted, forms a continuous closed chamber inflated to a pressure substantially exceeding atmospheric pressure when the tyre is in the condition in which it is normally used, but is not subject to any load;

- (b) is capable of being inflated and deflated without removal from the wheel or vehicle; and
- (c) is such that, when it is deflated and is subjected to a normal load, the sides of the tyre collapse;

“public works vehicle” means a mechanically propelled vehicle which is used on a road by or on behalf of –

- (a) the States of Jersey Public Services Department;
- (b) a Parish Authority;
- (c) the Jersey Postal Administration;
- (d) the Jersey Telecommunications Board;
- (e) the Jersey Electricity Company Limited;
- (f) the Jersey Gas Company Limited; or
- (g) the Jersey New Waterworks Company Limited,

for the purpose of works which such a body has a duty or power to carry out, and which is used only for the carriage of –

- (i) the crew, and
- (ii) goods which are needed for works in respect of which the vehicle is used;

“recut pneumatic tyre” means a pneumatic tyre in which all or part of its original tread pattern has been cut deeper or burnt deeper or a different tread pattern has been cut deeper or burnt deeper than the original tread pattern;

“refuse vehicle” means a vehicle designed for use and used solely in connection with street cleansing, the collection or disposal of refuse, or the collection or disposal of the contents of gullies or cesspools, registered under the 1993 Law;

“registered” means registered under the 1993 Law;

“relevant braking requirement” means a requirement that the brakes of a motor vehicle (as assisted, where a trailer is being drawn, by the brakes on the trailer) comply –

- (a) in a case to which item 1 in Table 1 in Article 18 applies, with the requirements specified in Article 18(5) for vehicles falling in that item;
- (b) in any other case, with the requirements specified in Article 18(5) for vehicle classes (a) and (b) in item 2 of that Table (whatever the date of first use of the motor vehicle and the date of manufacture of any trailer drawn by it may be);

“resilient tyre” means a tyre, not being a pneumatic tyre, which is of soft or elastic material, having regard to paragraph (6);

“restricted speed vehicle” means a vehicle displaying at its rear a “30” plate in accordance with the requirements of Schedule 15;

“retreaded tyre” means a tyre which has been reconditioned to extend its useful life by replacement of the tread rubber or by replacement of the tread rubber and renovation of the sidewall rubber;

“rigid vehicle” means a motor vehicle which is not constructed or adapted to form part of an articulated vehicle or articulated bus;

“rim diameter” shall be interpreted in accordance with the British Standard BS AU 50: Part 2: Section 1: 1980 entitled “British Standard Automobile Series: Specification for Tyres and Wheels Part 2, Wheels and rims Section 1. Rim profiles and dimensions (including openings for valves)” which came into effect on 28th November 1980;

“rim diameter size code” shall be interpreted in accordance with the British Standard referred to in the meaning given in this paragraph to “rim diameter”;

“secondary braking system” means a braking system of a vehicle applied by a secondary means of operation independent of the service braking system or by one of the sections comprised in a split braking system;

“service braking system” means the braking system of a vehicle which is designed and constructed to have the highest braking efficiency of any of the braking systems with which the vehicle is equipped;

“silencer” means a contrivance suitable and sufficient for reducing as far as may be reasonable the noise caused by the escape of exhaust gases from the engine of a motor vehicle;

“single-decked vehicle” means a vehicle upon which no part of a deck or gangway is vertically above another deck or gangway;

“split braking system”, in relation to a motor vehicle, means a braking system so designed and constructed that –

- (a) it comprises 2 independent sections of mechanism capable of developing braking force such that, excluding the means of operation, a failure of any part (other than a fixed member or a brake shoe anchor pin) of one of the said sections will not cause a decrease in the braking force capable of being developed by the other section;
- (b) the said 2 sections are operated by a means of operation which is common to both sections;
- (c) the braking efficiency of either of the said 2 sections can be readily checked;

“staircase” means a staircase by means of which passengers on a double-decked vehicle may pass to and from the upper deck of the vehicle;

“stepframe low loader” means a semi-trailer (not being a low loader) which is constructed and normally used for the carriage of engineering equipment and is so constructed that the upper surface of the major part of the load platform is at a height of less than 1 m above the ground when measured on level ground and when –

- (a) any adjustable suspension is at the normal travelling height;
- (b) all pneumatic tyres are suitably inflated for use when the vehicle is fully laden; and
- (c) the semi-trailer is unladen;

“stored energy”, in relation to a braking system of a vehicle, means energy (other than the muscular energy of the driver or the mechanical energy of a spring) stored in a reservoir for the purpose of applying the brakes under the control of the driver, either directly or as a supplement to the driver’s muscular energy;

“straddle carrier” means a motor vehicle constructed to straddle and lift its load for the purpose of transportation;

“statutory power of removal” means a power conferred by or under any enactment passed in Jersey to remove or move a vehicle from any road or from any part of a road;

“temporary use spare tyre” means a pneumatic tyre which is designed for use on a motor vehicle only –

(a) in the event of the failure of one of the tyres normally fitted to a wheel of the vehicle; and

(b) at a speed lower than that for which such normally fitted tyres are designed;

“towing implement” means a device on wheels designed for the purpose of enabling a motor vehicle to draw another vehicle by the attachment of that device to that other vehicle in such a manner that part of that other vehicle is secured to and either rests on or is suspended from the device and some but not all of the wheels on which the other vehicle normally runs are raised off the ground;

“trailer” means a vehicle drawn by a motor vehicle and shall be interpreted in accordance with paragraphs (11) and (13);

“train weight”, in relation to a motor vehicle which may draw a trailer, means the maximum laden weight for the motor vehicle together with any trailer which may be drawn by it;

“transverse plane” means a vertical plane at right angles to the longitudinal axis of a vehicle;

“trolley bus” means a bus adapted for use on roads without rails and moved by power transmitted thereto from some external source;

“Type Approval (Great Britain) Regulations” means the Motor Vehicles (Type Approval) (Great Britain) Regulations 1984 of the United Kingdom;

“Type Approval for Agricultural Vehicles Regulations” means the Agricultural or Forestry Tractors and Tractor Components (Type Approval) Regulations 1979 of the United Kingdom;

“Type Approval for Goods Vehicles Regulations” means the Type Approval for Goods Vehicles (Great Britain) Regulations 1982 of the United Kingdom;

“Type Approval Regulations” means the Motor Vehicles (Type Approval) Regulations 1980 of the United Kingdom;

“unbraked trailer” means any trailer other than one which, whether or not Article 15 or 16 applies to it, is equipped with a braking system in accordance with one of those Articles;

“unladen weight” means any weight of a vehicle or trailer inclusive of the body and all parts (the heavier being taken where alternative bodies or parts are used) which are necessary to or ordinarily used with the vehicle or trailer when working on a road, but exclusive of the weight of water, fuel or accumulators used for the purpose of the supply of power for the propulsion of the vehicle or, as the case may be, of any vehicle by which the trailer is drawn, and of loose tools and loose equipment;

“visiting force” means a visiting force of a listed country, as defined by Article 3(1) and (4) of the [Armed Forces \(Offences and Jurisdiction\) \(Jersey\) Law 2017](#);

“wheel” means a wheel the tyre or rim of which when the vehicle is in motion on a road is in contact with the ground; 2 wheels are to be regarded as one wheel in the circumstances specified in paragraph (8);

“wheeled”, in relation to a vehicle, means a vehicle so constructed that the whole weight of the vehicle is transmitted to the road surface by means of wheels;

“wide tyre” means a pneumatic tyre of which the area of contact with the road surface is not less than 300 mm in width when measured at right angles to the longitudinal axis of the vehicle;

“works trailer” means a trailer designed for use in private premises and used on a road only in delivering goods from or to such premises to or from a vehicle on a road in the immediate neighbourhood, or in passing from one part of any such premises to another or to other private premises in the immediate neighbourhood or in connection road works while at or in the immediate neighbourhood of the site of such works;

“works truck” means a motor vehicle (other than a straddle carrier) designed for use in private premises and used on a road only in delivering goods from or to such premises to or from a vehicle on a road in the immediate neighbourhood, or in passing from one part of any such premises to another or to other private premises in the immediate neighbourhood or in connection with road works while at or in the immediate neighbourhood of the side of such works.²

- (2) A reference in this Order to a Table, or to a numbered Table, is a reference to the Table, or to the Table bearing that number, in the Article or Schedule in which that reference occurs.
- (3) A reference in this Order to any enactment is a reference to that enactment as from time to time amended or re-enacted with or without modification, and for the purposes of this paragraph “enactment” includes an enactment of the United Kingdom, as it has effect on the coming into force of this Order.
- (4) For the purposes of this Order, the date on which a motor vehicle is first used is –
 - (a) in the case of a vehicle not falling within sub-paragraph (b) and which is registered, the date on which it was registered;
 - (b) in each of the following cases –
 - (i) a vehicle which is being or has been used under a trade licence issued under Article 8 of the 1993 Law (otherwise than for the purposes of demonstration or testing or of being delivered from premises of the manufacturer by whom it was made or of a distributor of vehicles, or dealer in vehicles, to premises of a distributor of vehicles, dealer in vehicles or purchaser thereof or to premises of a person obtaining possession thereof under a hiring agreement or hire purchase agreement),
 - (ii) a vehicle belonging, or which has belonged, to a home force and which is or was used or appropriated for the purposes of that force,
 - (iii) a vehicle belonging, or which has belonged, to a visiting force,

- (iv) a vehicle which has been used on roads outside Jersey before being imported into Jersey, and
 - (v) a vehicle which has been used otherwise than on roads after being sold or supplied by retail and before being registered,
- the date of manufacture of the vehicle.

In sub-paragraph (b)(v) “sold or supplied by retail” means sold or supplied otherwise than to a person acquiring it solely for the purpose of resale or re-supply for a valuable consideration.³

- (5) The date of manufacture of a vehicle to which the Type Approval for Goods Vehicles Regulations apply shall be the date of manufacture described in Regulation 2(4)(a) of those Regulations.
- (6) Save where otherwise provided in this Order a tyre shall not be deemed to be of soft or elastic material unless the said material is either –
 - (a) continuous round the circumference of the wheel; or
 - (b) fitted in sections so that so far as reasonably practicable no space is left between the ends thereof,and is of such thickness and design as to minimize, so far as reasonably possible, vibration when the vehicle is in motion and so constructed as to be free from any defect which might in any way cause damage to the surface of a road.
- (7) For the purpose of this Order a brake drum and a brake disc shall be deemed to form part of the wheel and not of the braking system.
- (8) For the purpose of this Order other than Articles 26 and 27 any 2 wheels of a motor vehicle or trailer shall be regarded as one wheel if the distance between the centres of the areas of contact between such wheels and the road surface is less than 460 mm.
- (9) For the purpose of this Order other than Articles 26 and 27 in counting the number of axles of, and in determining the sum of the weights transmitted to the road surface by any one axle of, a vehicle, all the wheels of which the centres of the areas of contact with the road surface can be included between any 2 transverse planes less than 0.5 m apart shall be treated as constituting one axle.
- (10) For the purpose of this Order, a reference to axles being closely-spaced is a reference to –
 - (a) 2 axles (not being part of a group of axles falling within sub-paragraph (b) or (c)) which are spaced at a distance apart of not more than 2.5 m;
 - (b) 3 axles (not being part of a group of axles falling within sub-paragraph (c)) the outermost of which are spaced at a distance apart of not more than 3.25 m; or
 - (c) 4 or more axles the outermost of which are spaced at a distance apart of not more than 4.6 m;

the number of axles for the purposes of these paragraphs being determined in accordance with paragraph (8), and a reference to any particular number of closely-spaced axles shall be construed accordingly.

- (11) The provisions of this Order relating to trailers do not apply to any part of an articulated bus.

- (12) For the purpose of paragraph (10), Articles 54, 82, 83 and 85 and Schedule 13, the distance between any 2 axles shall be obtained by measuring the shortest distance between the line joining the centres of the areas of contact with the road surface of the wheels of one axle and the line joining the centres of the areas of contact with the road surface of the wheels of the other axle.
- (13) For the purpose of the following provisions only, a composite trailer shall be treated as one trailer (not being a semi-trailer or a converter dolly) –
- (a) Articles 5, 82 and 89;
 - (b) paragraph (2) of, and items 4 and 11 in the Table in, Article 81;
 - (c) item 2 in the Table in Article 84.

2 Application and exemptions

- (1) Save where the context otherwise requires, this Order applies to both wheeled vehicles and track-laying vehicles.
- (2) Where a provision is applied by this Order to a motor vehicle first used on or after a specified date it does not apply to that vehicle if it was manufactured at least 6 months before that date.
- (3) Where an exemption from, or relaxation of, a provision is applied by this Order to a motor vehicle first used before a specified date it shall also apply to a motor vehicle first used on or after that date if it was manufactured at least 6 months before that date.
- (4) The Articles specified in an item in column 3 of the Table do not apply in respect of a vehicle of a class specified in that item in column 2.

TABLE⁴

(Article 2(4))

1	2	3
<i>Item</i>	<i>Class of vehicle</i>	<i>Articles which do not apply</i>
1	A vehicle proceeding to a port for export	The Articles in Part 2 insofar as they relate to construction and equipment, except Articles 16 (insofar as it concerns parking brakes), 20, 30, 34, 37 and 56 Articles 73 to 76 and 78
2 (a)	A vehicle brought temporarily into Jersey by a person resident outside Jersey, provided that the vehicle complies in every respect with the requirements relating to motor vehicles or trailers contained in – Article 21 and Article 22(1) of the Convention on Road Traffic concluded at Geneva on 19th September 1949 and Part 1, Part 2 (so far as it relates to direction	The Articles in Part 2 insofar as they relate to construction and equipment except Articles 5, 6, 8, 42 and 56 Articles 73 to 76 and 78

1	2	3
Item	Class of vehicle	Articles which do not apply
(b)	indicators and stop lights) and Part 3 of Annex 6 to that Convention; or Paragraphs I, III and VIII of Article 3 of the International Convention relative to Motor Traffic concluded at Paris on 24th April 1926	
3	A vehicle manufactured in Great Britain which complies with the requirement referred to in item 2 above and contained in the Convention of 1949, or, as the case may be, 1926 referred to in that item as if the vehicle had been brought temporarily into Jersey and is exempt from registration by virtue of the 1993 Law	The Articles in Part 2 insofar as they relate to construction and equipment, except Articles 5, 6, 8, 42 and 56 Articles 73 to 76 and 78
4	[deleted]	
5	A vehicle which has been submitted for an examination under the Law while it is being used on a road in connection with the carrying out of that examination and is being so used by a person who is empowered to carry out that examination, or by a person acting under the direction of a person so empowered	The Articles in Part 2 Articles 81 to 85 and 106
6	A motor car or a motor cycle in respect of which a certificate has been issued by the Inspector of Motor Traffic that it was designed before 1st January 1905 and constructed before 31st December 1905	Articles 16 (except insofar as it applies requirements 3 and 5 in Schedule 2), 21, 37(4), 70 and 105(4)
7(a)	A towing implement which is being drawn by a motor vehicle while it is not attached to any vehicle except the one drawing it if – (i) the towing implement is not being so drawn during the hours of darkness, and (ii) the vehicle by which it is being so drawn is not driven at a speed exceeding 20 mph; or	The Articles in Part 2 insofar as they relate to the construction and equipment of trailers, except Article 20
(b)	A vehicle which is being drawn by a motor vehicle in the exercise of a statutory power of removal	

- (5) Any reference to a broken-down vehicle shall include a reference to any towing implement which is being used for the drawing of any such vehicle.
- (6) The provisions of this Order shall have effect subject to any condition or restriction of any licence granted under Article 78 of the Law.
- (7) For the purposes of Article 78(3) of the Law, the fee to accompany an application for a licence authorising the use of a vehicle not complying with Orders under Article 77 of the Law is –
 - (a) if the application is for a licence for the use of the vehicle on a specified journey or for a specified purpose or for a period of not more than 12 months, £113.70;
 - (b) if the application is for a licence for the use of the vehicle in any other case, £201.70;
 - (c) if the application is a second or subsequent application (after an earlier application under Article 78 of the Law was refused within the period of 30 days before the second or subsequent application is made) and both or all the applications are for a licence for the use of the vehicle as referred to in sub-paragraph (b), £100.80.⁵
- (8) No fee is required under paragraph (7) in respect of a vehicle used for the purposes of a home force or of a visiting force.⁶
- (9) No fee is required under paragraph (7) in respect of a vehicle which is of a make and model specified in a list (specified zero emission motor vehicles) published under paragraph 4D of Schedule 2 to the [Motor Vehicle Registration \(General Provisions\) \(Jersey\) Order 1993](#).⁷

3 Trade description legislation

Nothing in any provision of this Order whereby any vehicle or any of its parts or equipment is required to be marked with a specification number or the registered certification trade mark of the British Standards Institution or with an approval mark, or whereby such a marking is treated as evidence of compliance with a standard to which the marking relates, shall be taken to authorize any person to apply any such marking to the vehicle, part or equipment in contravention of any enactment passed in Jersey relating to trade descriptions.

4 Compliance with Community Directives and ECE Regulations

- (1) For the purpose of any Article which requires or permits a vehicle to comply with the requirements of a Community Directive or an ECE Regulation, a vehicle shall be deemed so to have complied at the date of its first use only if –
 - (a) one of the certificates referred to in paragraph (2) has been issued in relation to it;
 - (b) the marking referred to in paragraph (3) has been applied; or
 - (c) it was, before it was used on a road, subject to relevant type approval requirements as specified in paragraph (4).
- (2) The certificates mentioned in paragraph (1) are –

- (a) a type approval certificate issued by the Secretary of State for Transport of the United Kingdom under regulation 5 of the Type Approval Regulations or of the Type Approval for Agricultural Vehicles Regulations;
- (b) a certificate of conformity issued by the manufacturer of the vehicle under regulation 6 of either of those regulations;
- (c) a certificate issued under a provision of the law of any member state of the European Union which corresponds to the said regulations 5 or 6; or
- (d) a sound level measurement certificate issued by the Secretary of State for Transport of the United Kingdom under regulation 4 of the Motor cycle (Sound Level Measurement Certificates) Regulations 1980 of the United Kingdom,

being in each case a certificate issued by reason of the vehicle's conforming to the requirements of the Community Directive in question.

- (3) The marking mentioned in paragraph (1) is a marking designated as an approval mark by regulation 4 of the Approval Marks Regulations, being in each case a mark shown in column 2 of an item in Schedule 2 to those regulations which refers, in column 5, to the ECE Regulation in question, applied as indicated in column 4 in that item.
- (4) A relevant type approval requirement is a requirement of the Type Approval (Great Britain) Regulations or the Type Approval for Goods Vehicles Regulations which appears –
 - (a) in column 4 of Table 1 in Schedule 1 in the item in which the Community Directive in question appears in column 3; or
 - (b) in column 4 of Table 2 in Schedule 1 in the item in which the ECE Regulation in question appears in column 3.

PART 2

THE CONSTRUCTION, EQUIPMENT AND MAINTENANCE OF VEHICLES

A – DIMENSIONS AND MANOEUVRABILITY

5 Length

- (1) Subject to paragraphs (2) and (3), the overall length of a vehicle or combination of vehicles of a class specified in an item in column 2 of the Table shall not exceed the maximum length specified in that item in column 3 of the Table, the overall length in the case of a combination of vehicles being calculated in accordance with Article 87(g) and (h).

TABLE

(Article 5(1))

1	2	3
<i>Item</i>	<i>Class of Vehicle</i>	<i>Maximum length (metres)</i>
	Vehicle Combinations	
1	A motor vehicle drawing one trailer, where the combination of vehicles does not meet the requirements of paragraph (7) and the trailer is not a semi-trailer	16.50
2	A motor vehicle drawing one trailer where the combination meets the requirements of paragraph (7) and the trailer is not a semi-trailer	16.85
3	An articulated bus	11
4	An articulated vehicle the semi-trailer of which does not meet the requirements of paragraph (8) and is not a low loader	11
5	An articulated vehicle, the semi-trailer of which meets the requirements of paragraph (8) and is not a low loader	11
6	An articulated vehicle, the semi-trailer of which is a low loader	11
	Motor Vehicles	
7	A wheeled motor vehicle	9.3
8	A track-laying motor vehicle	9.3
9	A large passenger carrying vehicle	9.7
	Trailers	
10	An agricultural trailed appliance manufactured on or after 1st December 1985	8
11	A semi-trailer which meets the requirements of paragraph (8)	8
12	A composite trailer being drawn by – (a) a goods vehicle being a motor vehicle having a maximum gross weight exceeding 3,500 kg; or (b) an agricultural motor vehicle	8
13	An agricultural trailer	8
14	Any other trailer not being an agricultural trailed appliance or a semi-trailer	6.7

- (2) In the case of a motor vehicle drawing one trailer where –
- (a) the motor vehicle is a showman’s vehicle as defined in paragraph 7 of Schedule 3 to the Vehicles Excise Act 1971 of the United Kingdom; and
 - (b) the trailer is used primarily as living accommodation by one or more persons and is not also used for the carriage of goods or burden which is not needed for the purpose of such residence in the vehicle,
- item 1 in the Table applies with the substitution of 22 m for 16.5 m and item 2 in the Table does not apply.
- (3) Items 1, 2, 4, 5 and 6 of the Table do not apply to –

- (a) a vehicle combination which includes a trailer which is constructed and normally used for the conveyance of indivisible loads of exceptional length;
 - (b) a vehicle combination consisting of a broken-down vehicle (including an articulated vehicle) being drawn by a motor vehicle in consequence of a breakdown; or
 - (c) an articulated vehicle, the semi-trailer of which is a low loader manufactured before 1st April 1991.
- (4) Items 10, 11, 12, 13 and 14 of the Table do not apply to –
- (a) a trailer which is constructed and normally used for the conveyance of indivisible loads of exceptional length;
 - (b) a broken-down vehicle (including an articulated vehicle) which is being drawn by a motor vehicle in consequence of a breakdown; or
 - (c) a trailer being a drying or mixing plant designed for the production of asphalt or of bituminous or tar macadam and used mainly for the construction, repair or maintenance of roads, or a road planing machine so used.
- (5) Where a motor vehicle is drawing 2 trailers, then none of those trailers may exceed an overall length of 7 m.
- (6) Where a motor vehicle is drawing –
- (a) 2 or more trailers; or
 - (b) one trailer constructed and normally used for the conveyance of indivisible loads of exceptional length –
- then –
- (i) the overall length of that motor vehicle shall not exceed 9.3 m, and
 - (ii) the overall length of the combination of vehicles, calculated in accordance with Article 87(g) and (h), shall not exceed 16.5 m, unless the conditions specified in paragraphs 1 and 2 of Schedule 14 have been complied with.
- (7) The requirements of this paragraph, in relation to a combination of vehicles, are that at least one of the vehicles in the combination is not a goods vehicle or, if both vehicles in the combination are goods vehicles that –
- (a) the maximum distance measured parallel to the longitudinal axis of the combination of vehicles from the foremost point of the loading area behind the driver's cab to the rear of the trailer, less the distance between the rear of the motor vehicle and the front of the trailer, does not exceed 14.15 m; and
 - (b) the maximum distance measured parallel to the longitudinal axis of the combination of vehicles from the foremost point of the loading area behind the driver's cab to the rear of the trailer does not exceed 14.5 m,
- but sub-paragraph (a) shall not apply if both vehicles in the combination are car transporters.
- (8) The requirements of this paragraph, in relation to a semi-trailer, are that –
- (a) the longitudinal distance from the axis of the king-pin to the rear of the semi-trailer does not exceed 12 m; and

- (b) no point in the semi-trailer forward of the transverse plane passing through the axis of the king-pin is more than 2.04 m.
- (9) For the purposes of paragraph (7) –
- (a) where the forward end of the loading area of a motor vehicle is bounded by a wall, the thickness of the wall shall be regarded as part of the loading area; and
- (b) any part of a vehicle designed primarily for use as a means of attaching another vehicle to it and any fitting designed for use in connection with any such part shall be disregarded in determining the distance between the rear of a motor vehicle and the front of a trailer being drawn by it.
- (10) For the purpose of paragraph (8) the longitudinal distance from the axis of the king-pin to the rear of a semi-trailer is the distance between a transverse plane passing through the axis of the king-pin and the rear of the semi-trailer.
- (11) Where a semi-trailer has more than one king-pin or is constructed so that it can be used with a king-pin in different positions, references in this Article to a distance from the king-pin shall be construed as the distance from the rearmost king-pin, or as the case may be, the rearmost king-pin position.
- (12) For the purpose of paragraphs (7), (8) and (10) –
- (a) a reference to the front of a vehicle is a reference to the transverse plane passing through the extreme forward projecting points of the vehicle; and
- (b) a reference to the rear of a vehicle is a reference to the transverse plane passing through the extreme rearward projecting points of the vehicle,
- inclusive (in each case) of all parts of the vehicle of any receptacle which is of a permanent character and accordingly strong enough for repeated use, and any fitting on, or attached to the vehicle but exclusive of –
- (i) the things set out in sub-paragraph (a) of the definition of “overall length” in Article 1(1), and
- (ii) in the case of a semi-trailer, the things set out in sub-paragraph (b)(i) of that definition.
- (13) Where a broken-down articulated vehicle is being towed by a motor vehicle in consequence of a breakdown –
- (a) paragraph (6) shall have effect in relation to the combination of vehicles as if sub-paragraph (b) were omitted; and
- (b) for the purposes of paragraph (5) and of paragraph (6) as so modified, the articulated vehicles shall be regarded as a single trailer.
- (14) No person shall use or cause or permit to be used on a road, a trailer with an overall length exceeding 16.5 m unless the requirements of paragraphs 1 and 2 of Schedule 14 are complied with.

6 Width

- (1) Save as provided in paragraph (2), the overall width of a vehicle of a class specified in an item in column 2 of the Table shall not exceed the maximum width specified in column 3 in that item.

TABLE
(Article 6(1))

1	2	3
<i>Item</i>	<i>Class of vehicle</i>	<i>Maximum width (metres)</i>
1	A locomotive other than an agricultural motor vehicle	2.3
2	A refrigerated vehicle	2.3
3	Any other motor vehicle	2.3
4	A trailer drawn by a motor vehicle having maximum gross weight (determined as provided in Part 1 of Schedule 10) exceeding 3,500 kg	2.3
5	An agricultural trailer	2.3
6	An agricultural trailed appliance	2.5
7	Any other trailer drawn by a vehicle other than a motor cycle	2.3
8	A trailer drawn by a motor cycle	1.5

- (2) Paragraph (1) does not apply to a broken-down vehicle which is being drawn in consequence of the breakdown.
- (3) No person shall use or cause or permit to be used on a road a wheeled agricultural motor vehicle drawing a wheeled trailer if, when the longitudinal axes of the vehicles are parallel but in different vertical planes, the overall width drawn of the 2 vehicles, measured as if they were one vehicle, exceeds 2.3 m.
- (4) In this Article “refrigerated vehicle” means any vehicle which is specially designed for the carriage of goods at low temperature.

7 Height

The overall height of a bus shall not exceed 4.57 m.

8 Indication of overall travelling height

- (1) This Article applies to every motor vehicle which is –
- (a) constructed or adapted so as to be capable of hoisting and carrying a skip;
 - (b) carrying a container;
 - (c) drawing a trailer or semi-trailer carrying a container;
 - (d) engineering plant;
 - (e) carrying engineering equipment; or
 - (f) drawing a trailer or semi-trailer carrying engineering equipment.
- (2) No person shall use or cause or permit to be used on a road a vehicle to which this Article applies if the overall travelling height exceeds 3.66 m unless there is carried in the vehicle in the manner specified in paragraph (3) a notice clearly indicating both in feet and inches and millimetres and in figures not less than 40 mm tall, the overall travelling height.

(3) The notice referred to in paragraph (2) shall be attached to the vehicle in such a manner that it can be read by the driver when in the driving position.

(4) In this Article –

“overall travelling height” means not less than and not above 25 mm more than the distance between the ground and the point on the motor vehicle, or on any trailer drawn by it, or on any load being carried by it, or on any equipment which is fitted to the said motor vehicle or trailer, which is farthest from the ground, and for the purpose of determining the overall travelling height –

- (a) the tyres of the motor vehicle and of any trailer which it is drawing shall be suitably inflated for the use to which the vehicle or combination of vehicles is being put;
- (b) the surface under the motor vehicle and any trailer which it is drawing and any load which is being carried on and any equipment which is fitted to any part of the said vehicle or combination of vehicles and which projects beyond any part of the said vehicle or combination of vehicles shall be reasonably flat; and
- (c) any equipment which is fitted to the motor vehicle or any trailer which it is drawing shall be stowed in the position in which it is to proceed on the road;

“skip” means an article of equipment designed and constructed to be carried on a road vehicle and to be placed on a road or other land for the storage of materials, or for the removal and disposal of rubble, waste, household or other rubbish or earth.

9 Overhang

(1) The overhang of a wheeled vehicle of a class specified in an item in column 2 of the Table shall not, subject to any exemption specified in that item in column 4, exceed the distance specified in that item in column 3.

TABLE
(Article 9(1))

1	2	3	4
<i>Item</i>	<i>Class of vehicle</i>	<i>Maximum overhang</i>	<i>Exemptions</i>
1	Motor tractor	1.83 m	(a) a track-laying vehicle; (b) an agricultural motor vehicle;
2	Heavy motor car and motor car	60% of the distance between the transverse plane which passes through the centre or centres of the foremost wheel or wheels and the transverse plane which passes through the foremost point from which the overhang is to be measured as provided in Article 1(1)	(a) a bus; (b) a refuse vehicle; (c) a works truck; (d) a track-laying vehicle; (e) an agricultural motor vehicle; (f) a motor car which is an ambulance; (g) a vehicle designed to dispose of its load to the rear, if the overhang does

1	2	3	4
<i>Item</i>	<i>Class of vehicle</i>	<i>Maximum overhang</i>	<i>Exemptions</i>
			<p>not exceed 1.15 m;</p> <p>(h) a vehicle first used before 2nd January 1933;</p> <p>(i) a vehicle first used before 1st January 1966 if –</p> <p style="padding-left: 20px;">(i) the distance between the centres of the rearmost and foremost axles does not exceed 2.29 m, and</p> <p style="padding-left: 20px;">(ii) the distance specified in column 3 is not exceeded by more than 76 mm;</p> <p>(j) heating plant on a vehicle designed and mainly used to heat the surface of a road or other similar surface in the process of construction, repair or maintenance shall be disregarded.</p>

- (2) In the case of an agricultural vehicle the distance measured horizontally and parallel to the longitudinal axis of the rear portion of the vehicle between the transverse planes passing through the rearmost point of the vehicle and through the centre of the rear or the rearmost axle shall not exceed 3 m.

10 Minimum ground clearance

- (1) Save as provided in paragraph (2), a wheeled trailer which is –

- (a) a goods vehicle; and
- (b) manufactured on or after 1st April 1984,

shall have a minimum ground clearance of not less than 160 mm if the trailer has an axle interspace of more than 6 m but less than 11.5 m, and a minimum ground clearance of not less than 190 mm if the trailer has an axle interspace of 11.5 m or more.

- (2) Paragraph (1) shall not apply in the case of a trailer –

- (a) which is fitted with a suspension system with which, by the operation of a control, the trailer may be lowered or raised, while that system is being operated to enable the trailer to pass under a bridge or other obstruction over a road provided that at such times the system is operated so that no part of the trailer (excluding any wheel) touches the ground or is likely to do so; or
- (b) while it is being loaded or unloaded.

(3) In this Article –

“axle interspace” means –

- (a) in the case of a semi-trailer, the distance between the point of support of the semi-trailer at its forward end and, if it has only one axle, the centre of that axle, or if it has more than one axle, the point halfway between the centres of the foremost and rearmost of those axles; and
- (b) in the case of any other trailer, the distance between the centre of its front axle or, if it has more than one axle at the front, the point halfway between the centres of the foremost and rearmost of those axles, and the centre of its rear axle or, if it has more than one axle at the rear, the point halfway between the centre of the foremost and rearmost of those axles; and

“ground clearance” means the shortest distance between the ground and the lowest part of that position of the trailer (excluding any part of a suspension, steering or braking system attached to any axle, and wheel and any air skirt) which lies within the area formed by the overall width of the trailer and the middle 70% of the axle interspace, such distance being ascertained when the trailer –

- (a) is fitted with suitable tyres which are inflated to a pressure recommended by the manufacturer; and
- (b) is reasonably horizontal and standing on ground which is reasonably flat.

11 Turning circle – buses

- (1) This Article applies to a bus first used on or after 1st April 1982.
- (2) Every vehicle to which this Article applies shall be able to move on either lock so that no part of it projects outside the area contained between concentric circles with radii of 12 m and 5.3 m.
- (3) When a vehicle to which this Article applies moves forward from rest, on either lock, so that its outmost point describes a circle of 12 m radius, no part of the vehicle shall project beyond the longitudinal plane which, at the beginning of the manoeuvre, defines the overall width of the vehicle on the side opposite to the direction in which it is turning by more than –
 - (a) 0.8 m if it is a rigid vehicle; or
 - (b) 1.2 m if it is an articulated bus.
- (4) For the purpose of paragraph (3) the 2 rigid portions of an articulated bus shall be in line at the beginning of the manoeuvre.

12 Turning circle-articulated vehicles other than those incorporating a car transporter

- (1) Subject to paragraphs (2) and (3), this Article applies to an articulated vehicle having an overall length exceeding 11 m.
- (2) This Article does not apply to an articulated vehicle, the semi-trailer of which –
 - (a) was manufactured before the 1st April 1990; and
 - (b) has an overall length that does not exceed the overall length it had on that date.

- (3) This Article does not apply to an articulated vehicle the semi-trailer of which is –
 - (a) a car transporter;
 - (b) a low loader;
 - (c) a stepframe low loader; or
 - (d) constructed and normally used for the conveyance of indivisible loads of exceptional length.
- (4) Every vehicle to which this Article applies shall be able to move on either lock so that, disregarding the things set out in sub-paragraphs (a) to (m) in the definition of “overall width” in Article 1(1), no part of it projects outside the area contained between concentric circles with radii of 12.5 m and 5.3 m.

13 Turning circle-articulated vehicles incorporating a car transporter

- (1) Subject to paragraphs (2) and (3), this Article applies to an articulated vehicle having an overall length exceeding 11 m, the semi-trailer of which is a car transporter.
- (2) This Article does not apply to an articulated vehicle, the semi-trailer of which satisfies the following conditions –
 - (a) it was manufactured before 1st April 1990; and
 - (b) the distance from the front of the trailer to the rearmost axle is no greater than it was on that date.
- (3) This Article does not apply to an articulated vehicle the semi-trailer of which is –
 - (a) a low loader; or
 - (b) a stepframe low loader.
- (4) Every articulated vehicle to which this Article applies shall be able to move on either lock so that, disregarding the things set out in sub-paragraphs (a) to (m) in the definition of “overall width” in Article 1(1), no part of –
 - (a) the motor vehicle drawing the car transporter; or
 - (b) the car transporter to the rear of the transverse plane passing through the king-pin,projects outside the area between concentric circles with radii at 12.5 m and 5.3 m.

14 Connecting sections and direction-holding of articulated buses

- (1) This Article applies to every articulated bus first used on or after 1st April 1982.
- (2) The connecting section of the 2 parts of every articulated bus to which this Article applies shall be constructed so as to comply with the provisions relating to such a section specified in paragraph 5.9 in ECE Regulation 36 as regards vehicles within the scope of that Regulation.
- (3) Every articulated bus to which this Article applies shall be constructed so that when the vehicle is moving in a straight line the longitudinal median planes of its 2 parts coincide and form a continuous plane without any deflection.

*B – BRAKES***15 Braking systems of certain vehicles first used on or after 1st April 1983**

- (1) Save as provided in paragraphs (2), (3) and (4), the braking system of every wheeled vehicle of a class specified in an item in column 2 of the Table which, in the case of a motor vehicle, is first used on or after 1st April 1983 or which, in the case of a trailer, is manufactured on or after 1st October 1982 shall comply with the construction, fitting and performance requirements specified in Annexes I, II and VII to Community Directive 79/489, and if relevant, Annexes III, IV, V, VI and VIII to that Directive, in relation to the category of vehicles specified in that item in column 3:

Provided that it shall be lawful for any vehicle of such a class which, in the case of a motor vehicle, was first used before 1st April 1983 or, in the case of a trailer, was manufactured before 1st October 1982 to comply with the said requirements instead of complying with Articles 16 and 17.

- (2) Save as provided in paragraph (6), paragraphs (7)(b) and (c) and paragraphs (8) and (10), the braking system of every wheeled vehicle of a class specified in an item in column 2 of the Table which, in the case of a motor vehicle is first used on or after the relevant date or which, in the case of a trailer, is manufactured on or after the relevant date, shall comply with the construction, fitting and performance requirements specified in Annexes I, II and VII to Community Directive 85/647, and if relevant, Annexes III, IV, V, VI, VIII, X, XI and XII to that Directive, in relation to the category of vehicles specified in that item in column 3:

Provided that it shall be lawful for any vehicle of such a class which, in the case of a motor vehicle was first used before the relevant date or which, in the case of a trailer, was manufactured before the relevant date to comply with the said requirements instead of complying with paragraph (1) or with Articles 16 and 17.

- (3) In paragraph (2), the relevant date in relation to a vehicle of a class specified in item 1 or 2 of the Table is 1st April 1990, in relation to a vehicle specified in item 4 of that Table is 1st April 1992, in relation to a vehicle in items 7, 8, 9 or 10 of that Table is 1st October 1988 and in relation to a vehicle in any other class is 1st April 1989.

- (4) Save as provided in paragraph (6), paragraphs (7)(b) and (c) and paragraphs (8) and (10), the braking system of every wheeled vehicle of a class specified in an item in column 2 of the Table which in the case of a motor vehicle is first used on or after 1st April 1992 or in the case of a trailer is manufactured on or after 1st October 1991 shall comply with the construction, fitting and performance requirements specified in Annexes I, II and VII to the Community Directive 88/194, and if relevant, Annexes III, IV, V, VI, VIII, X, XI and XII to that Directive, in relation to the category of vehicles specified in that item in column 3:

Provided that it shall be lawful for any vehicle of such a class which, in the case of a motor vehicle was first used before 1st April 1992 or which, in the case of a trailer, was manufactured before 1st October 1991, to comply with the said requirements instead of complying with paragraph (1) or (2), or with Articles 16 and 17.

- (5) Save as provided in paragraphs (6), (7), (8) and (11), the braking system of every wheeled vehicle of a class specified in an item in column 2 of the Table which, in the case of a motor vehicle, is first used on or after 1st April 1995 or which, in the

case of a trailer, is manufactured on or after that date shall comply with the construction, fitting and performance requirements specified in Annexes I, II and VII to Community Directive 91/422, and if relevant, Annexes III, IV, V, VI, VIII, X, XI and XII to that Directive in relation to the category of vehicles specified in that item in column 3:

Provided that it shall be lawful for any vehicle of such a class which, in the case of a motor vehicle, was first used before 1st April 1995 or which, in the case of a trailer, was manufactured before that date to comply with the said requirements instead of complying with paragraph (1), (2) or (4) or with Articles 16 and 17.

TABLE
(Article 15(1))

1	2	3
<i>Item</i>	<i>Class of vehicle</i>	<i>Vehicle Category in the Community Directive</i>
1	Passenger vehicles and dual-purpose vehicles which have 3 or more wheels except – (a) dual-purpose vehicles constructed and adapted to carry not more than 2 passengers exclusive of the driver; (b) motor cycles with sidecar attached; (c) vehicles having 3 wheels, an unladen weight not exceeding 410 kg, a maximum design speed not exceeding 50 km/h and an engine capacity not exceeding 50 cc; (d) Buses	M1
2	Buses having a maximum gross weight which does not exceed 5,000 kg	M2
3	Buses having a maximum gross weight which exceeds 5,000 kg	M3
4	Dual-purpose vehicles not within item 1; and goods vehicles, having a maximum gross weight which does not exceed 3,500 kg, and not being motor cycles with a sidecar attached.	N1
	Goods vehicles with a maximum gross weight which –	
5	Exceeds 3,500 kg but does not exceed 12,000 kg	N2
6	Exceeds 12,000 kg	
	Trailers with a maximum total design axle weight which –	
7	Does not exceed 750 kg	O1
8	Exceeds 750 kg but does not exceed 3,500 kg	O2
9	Exceeds 3,500 kg but does not exceed 10,000 kg	O3
10	Exceeds 10,000 kg	O4

- (6) The requirements specified in paragraphs (1), (2) and (4) do not apply to –
- (a) an agricultural trailer or agricultural trailed appliance that is not, in either case, drawn at a speed exceeding 20 mph;

- (b) a locomotive;
 - (c) a motor tractor;
 - (d) an agricultural motor vehicle unless it is first used after 1st June 1986 and is driven at more than 20 mph;
 - (e) a vehicle which has a maximum speed not exceeding 25 km/h;
 - (f) a works trailer;
 - (g) a works truck;
 - (h) a public works vehicle;
 - (i) a trailer designed and constructed, or adapted, to be drawn exclusively by a vehicle to which sub-paragraph (b), (c), (e), (g) or (h) applies; or
 - (j) a trailer mentioned in Article 16(3)(b), (d), (e), (f) and (g).
- (7) The requirements specified in paragraphs (1), (2) and (4) shall apply to the classes of vehicles specified in the Table so that –
- (a) in item 3, the testing requirements specified in paragraphs 1.5.1 and 1.5.2 of Annex II to Community Directives 79/489, 85/647, 88/194 and 91/422 shall apply to every vehicle specified in that item other than –
 - (i) a double-decked vehicle first used before 1st October 1983, or
 - (ii) a vehicle of a type in respect of which a member state of the European Economic Community has issued a type approval certificate in accordance with Community Directive 79/489, 85/647 or 88/194;
 - (b) in items 2 and 3 –
 - (i) the requirements specified in paragraph 1.1.4.2 of Annex II to Community Directive 79/489, 85/647, 88/194 and 92/422 shall not apply in relation to any vehicle first used before 1st January 1999,
 - (ii) those requirements shall not apply in relation to any relevant bus first used on or after that date,
 - (iii) sub-note (2) to paragraph 1.17.2 of Annex I to Community Directive 85/647, 88/194 and 91/422 shall not apply in relation to any vehicle,and for the purposes of this sub-paragraph “relevant bus” means a bus that is not a coach;
 - (c) in items 1, 2, 3, 4, 5 and 6, in the case of vehicles constructed or adapted for use by physically handicapped drivers, the requirements in paragraph 2.1.2.1 of Annex I to Community Directive 79/489 that the driver must be able to achieve the braking action mentioned in that paragraph from the driver’s driving seat without removing the driver’s hands from the steering control shall be modified so as to require that the driver is able to achieve that action while continuing to steer the vehicle; and
 - (d) in items 1, 4, 5, 6, 7, 8, 9 and 10 the requirement specified in paragraph 1.1.4.2 of Annex II to Community Directive 79/489 shall not apply to a vehicle first used (in the case of a motor vehicle) or manufactured (in the case of a trailer) before the relevant date as defined in paragraph (3) if either –

- (i) following a test in respect of which the fee numbered 26024/26250 to 26257, prescribed in Schedule 1 of the Motor Vehicles (Type Approval and Approval Marks) (Fees) Regulations 1994 of the United Kingdom or the corresponding fee prescribed under any corresponding previous enactment is payable, a document is issued by the Secretary of State for Transport of the United Kingdom indicating that, at the date of manufacture of the vehicle, the type to which it belongs complied with the requirements specified in Annex 13 to ECE Regulation 13.03, 13.04, 13.05 or 13.06, or
 - (ii) as a result of a notifiable alteration to the vehicle, within the meaning of regulation 3 of the Plating and Testing Regulations, a fitment has been approved as complying with the requirements mentioned in clause (i).
- (8) The requirements specified in paragraph (2) shall apply to a road tanker subject to the exclusion of paragraph 4.3 of Annex X to Community Directive 85/647.
- (9) Instead of complying with paragraph (1), a vehicle to which this Article applies may comply with ECE Regulation 13.03, 13.04, 13.05 or 13.06.
- (10) Instead of complying with paragraph (2), a vehicle to which this Article applies may comply with ECE Regulation 13.05 or 13.06.
- (11) Instead of complying with paragraph (4), a vehicle to which this Article applies may comply –
 - (a) in the case of a trailer manufactured before 1st April 1992, with ECE Regulation 13.05 or 13.06; or
 - (b) in the case of any vehicle not falling within sub-paragraph (a), with ECE Regulation 13.06.
- (12) In paragraph (8) “road tanker” means any vehicle or trailer which carries liquid fuel in a tank forming part of the vehicle or trailer other than that containing the fuel which is used to propel the vehicle, and also includes any tank with a capacity exceeding 3m³ carried on a vehicle.
- (13) In this Article and in relation to the application to any vehicle of any provision of Community Directive 85/647, the definitions of “semi-trailer”, “full trailer” and “centre-axle trailer” set out in that Directive shall apply and the meaning of “semi-trailer” in Article 1(1) shall not apply.

16 Braking systems of vehicles to which Article 15 does not apply

- (1) Save as provided in paragraphs (2) and (3), this Article applies to every vehicle to which Article 15 does not apply.
- (2) Paragraph (4) does not apply to a vehicle which complies with Article 15 by virtue of the proviso to paragraphs (1), (2), (4) or (5) of Article 15, or which complies with Community Directive 79/489, 85/647, 88/194 or 91/422 or ECE Regulation 13.03, 13.04, 13.05 or 13.06.
- (3) This Article does not apply to the following vehicles, except in the case of a vehicle referred to in sub-paragraph (a) insofar as the Article concerns parking brakes (requirements 16 to 18 in Schedule 2)–

- (a) a locomotive first used before 2nd January 1933, propelled by steam, and with an engine which is capable of being reversed;
- (b) a trailer which –
- (i) is designed for use and used for street cleansing and does not carry any load other than its necessary gear and equipment,
 - (ii) has a maximum total design axle weight which does not exceed 750 kg,
 - (iii) is an agricultural trailer manufactured before 1st July 1947 drawn by a motor tractor or an agricultural motor vehicle if the trailer –
 - (A) has a laden weight not exceeding 4,070 kg, and
 - (B) is the only trailer being drawn, and
 - (C) is drawn at a speed not exceeding 10 mph, or
 - (iv) is drawn by a motor cycle in accordance with Article 90;
- (c) an agricultural trailed appliance;
- (d) an agricultural trailed appliance conveyor;
- (e) a broken-down vehicle;
- (f) before 1st October 1986 –
- (i) a trailer with an unladen weight not exceeding 103 kg which was manufactured before 1st October 1982, and
 - (ii) a gritting trailer; or
- (g) on or after 1st October 1986 a gritting trailer with a maximum gross weight not exceeding 2,000 kg.
- (4) Save as provided in paragraph (10), a vehicle of a class specified in an item in column 2 of Table 1 shall comply with the requirements shown in column 3 in that item, subject to any exemptions or modifications shown in column 4 in that item, reference to numbers in column 3 being references to the requirements so numbered in Schedule 2.

TABLE 1

(Article 16(4))

1	2	3	4
<i>Item</i>	<i>Class of vehicle</i>	<i>Requirements in Schedule 2</i>	<i>Exemptions or modifications</i>
Motor cars			
1	First used before 1st January 1915	3, 6, 7, 13, 16	Requirements 13 and 16 do not apply to a motor car with less than 4 wheels
2	First used on or after 1st January 1915 but before 1st April 1938	1, 4, 6, 7, 9, 16	A works truck within items 1 to 11 is not subject to requirements 1, 2, 3

1	2	3	4
<i>Item</i>	<i>Class of vehicle</i>	<i>Requirements in Schedule 2</i>	<i>Exemptions or modifications</i>
			or 4 if it is equipped with one braking system with one means of operation
3	First used on or after 1st April 1938 and being either a track-laying vehicle or a vehicle first used before 1st January 1968	1, 4, 6, 7, 8, 9, 16	
4	Wheeled vehicles first used on or after 1st January 1968	1, 4, 6, 7, 8, 9, 15, 18	
Heavy motor cars			
5	First used before 15th August 1928	1, 6, 16	
6	First used on or after 15th August 1928 but before 1st April 1938	1, 4, 6, 7, 8, 16	
7	First used on or after 1st April 1938 and being either a track-laying vehicle first used before 1st January 1968	1, 4, 6, 7, 8, 9, 16	
8	Wheeled vehicles first used on or after 1st January 1968	1, 4, 6, 7, 8, 9, 15, 18	
Motor cycles and motor tricycles			
9	First used before 1st January 1927	3, and, in the case of 3-wheeled vehicles, 16	
10	First used on or after 1st January 1927 but before 1st January 1968	2, 7 and, in the case of 3-wheeled vehicles, 16	
11	First used on or after 1st January 1968 and not being a motor cycle to which paragraph (5) applies	2, 7 and, in the case of 3-wheeled vehicles, 18	
Locomotives			
12	Wheeled vehicles first used before 1st June 1955	3, 6, 12, 16	
13	Wheeled vehicles first used on or after 1st June 1955 but before 1st January 1968	3, 4, 6, 7, 8, 9, 18	
14	Wheeled vehicles first used on or after 1st January 1968	3, 4, 6, 7, 8, 9, 18	
15	Track-laying vehicles	3, 6, 16	
Motor tractors			
16	Wheeled vehicles first used before 14th January 1931 and track-laying vehicles first used before 1st April 1938	3, 4, 6, 7, 16	Industrial tractors within items 16 to 19 are subject to requirement 5 instead of requirement 4
17	Wheeled vehicles first used on or	3, 4, 6, 7, 9, 16	

1	2	3	4
<i>Item</i>	<i>Class of vehicle</i>	<i>Requirements in Schedule 2</i>	<i>Exemptions or modifications</i>
	after 14th January 1931 but before 1st April 1938		
18	Wheeled vehicles first used on or after 1st April 1938 but before 1st January 1968	3, 4, 6, 7, 8, 9, 16	
19	Wheeled vehicles first used on or after 1st January 1968	3, 4, 6, 7, 8, 9, 18	
20	Track-laying vehicles first used on or after 1st April 1938	3, 4, 6, 7, 8, 16	
Wheeled agricultural motor vehicles not driven at more than 20 mph			
21	First used before 1st January 1968	3, 4, 6, 7, 8, 16	
22	First used on or after 1st January 1968 but before 9th February 1980	3, 4, 6, 7, 8, 18	
23	First used on or after 9th February 1980	3, 5, 6, 7, 8, 18	
Invalid carriages			
24	Whenever first used	3, 13	
Trailers			
25	Manufactured before 1st April 1938	3, 10, 14, 17	
26	Manufactured on or after 1st April 1938 and being either a track-laying vehicle, an agricultural trailer or a vehicle manufactured before 1st January 1968	3, 8, 10, 14, 17	Agricultural trailers are not subject to requirement 8
27	Wheeled vehicles manufactured on or after 1st January 1968, not being an agricultural trailer	3, 4, 8, 11, 15, 18	Trailers equipped with brakes which come into operation on the overrun of the vehicle are not subject to requirement 15

Provided that wheeled agricultural motor vehicles not driven at more than 20 mph are excluded from all items other than items 21 to 23.

- (5) Subject to paragraphs (7) and (8), the braking system of a motor cycle to which this Article applies and which is –
- (a) of a class specified in an item in column 2 of Table 2; and
 - (b) first used on or after 1st April 1987 and before 22nd May 1995;
- shall comply with ECE Regulation 13.05, 78 or 78.01 in relation to the category of vehicles specified in that item in column 3.
- (6) Subject to paragraph (8), the braking system of a motor cycle to which this Article applies and which is –
- (a) of a class specified in an item in column 2 of Table 2; and

(b) first used on or after 22nd May 1995;

shall comply with ECE Regulation 78.01 in relation to the category of vehicles specified in that item in column 3.

TABLE 2
(Article 16(5) and (6))

<i>Item</i>	<i>Class of vehicle</i>	<i>Vehicle Category in ECE Regulations</i>
1	Vehicles (without a sidecar attached) with 2 wheels, an engine capacity not exceeding 50 cc and a maximum design speed not exceeding 50 km/h	L.1
2	Vehicles with 3 wheels (including 2-wheeled vehicles with a sidecar attached) and with an engine capacity not exceeding 50 cc and a maximum design speed not exceeding 50 km/h	L.2
3	Vehicles with 2 wheels (without a sidecar attached) and with – (a) an engine capacity exceeding 50 cc; or (b) a maximum design speed exceeding 50 km/h	L.3
4	Vehicles with 2 wheels, a sidecar attached and – (a) an engine capacity exceeding 50 cc; or (b) a maximum design speed exceeding 50 km/h	L.4

- (7) In relation to a motor cycle with 2 wheels manufactured by Piaggio Veicoli Europei Societa per Azione and known as the Cosa 125, the Cosa 125E, the Cosa L125, the Cosa LX125, the Cosa 200, the Cosa 200E, the Cosa L200 or the Cosa LX200, paragraph (5) shall have effect as if ECE Regulation 13.05 were modified by –
- the omission of paragraph 4.4 (approval marks); and
 - in paragraph 5.3.1.1 (independent braking devices and controls), the omission of the word “independent” in the first place where it appears,
- but this paragraph shall not apply to a motor cycle first used on or after 1st July 1991.
- (8) Paragraph (5) does not apply to a works truck or to a vehicle constructed or assembled by a person not ordinarily engaged in the business of manufacturing vehicles of that description.
- (9) Paragraph (6) does not apply to –
- a vehicle with a maximum speed not exceeding 25 km/h; or
 - a vehicle fitted for an invalid driver.
- (10) Instead of complying with the provisions of paragraph (4) an agricultural motor vehicle may comply with Community Directive 76/432.

17 Vacuum or pressure brakes warning devices

- (1) Save as provided in paragraph (2), every motor vehicle which is equipped with a braking system which embodies a vacuum or pressure reservoir or reservoirs shall be equipped with a device so placed as to be readily visible to the driver of the vehicle and which is capable of indicating any impending failure of, or deficiency in, the vacuum or pressure system.
- (2) The requirement specified in paragraph (1) does not apply in respect of –
 - (a) a vehicle to which Article 15(1), (2), (4) or (5) applies, or which complies with the requirements of that Article, of Community Directive 79/489, 85/647, 88/194 or 91/422 or of ECE Regulation 13.03, 13.04, 13.05 or 13.06;
 - (b) an agricultural motor vehicle which complies with Community Directive 76/432;
 - (c) a vehicle with an unladen weight not exceeding 3,050 kg propelled by an internal combustion engine, if the vacuum in the reservoir or reservoirs is derived directly from the induction system of the engine and if in the event of a failure of, or deficiency in, the vacuum system, the brakes of that braking system are sufficient under the most adverse conditions to bring the vehicle to rest within a reasonable distance; or
 - (d) a vehicle first used before 1st October 1937.

18 Maintenance and efficiency of brakes

- (1) Every part of every braking system and of the means of operation thereof fitted to a vehicle shall be maintained in good and efficient working order and be properly adjusted.
- (2) Without prejudice to paragraph (5), where a vehicle is fitted with an anti-lock braking system (“ABS”), then while the condition specified in paragraph (3) is fulfilled, any fault in the ABS shall be disregarded for the purposes of paragraph (1).
- (3) The condition is fulfilled while the vehicle is completing a journey at the beginning of which the ABS was operating correctly or is being driven to a place where the ABS is to undergo repairs.
- (4) Paragraph (5) applies to every wheeled motor vehicle except –
 - (a) an agricultural motor vehicle which is not driven at more than 20 mph;
 - (b) a works truck;
 - (c) a pedestrian-controlled vehicle; and
 - (d) an industrial tractor.
- (5) Every vehicle to which this paragraph applies and which is of a class specified in an item in column 2 of Table 1 shall, subject to any exemption shown for that item in column 4, be so maintained that –
 - (a) its service braking system has a total braking efficiency not less than that shown in column 3(a) for that item; and

- (b) if the vehicle is a heavy motor car, a motor car first used on or after 1st January 1915 or a motor cycle first used on or after 1st January 1927, its secondary braking system has a total braking efficiency not less than that shown in column 3(b) for those items:

Provided that a reference in Table 1 to a trailer is a reference to a trailer required by Article 15 or 16 to be equipped with brakes.

TABLE 1
(Article 18(1))

1 <i>Item</i>	2 <i>Class of vehicle</i>	3		4 <i>Exemptions</i>	
		<i>Efficiencies (%)</i>			
		(a)	(b)		
1	A vehicle to which Article 15 applies or which complies in all respects other than its braking efficiency with the requirements of that Article or with Community Directive 79/489, 88/647, 88/194 or 91/422 or with ECE Regulation 13.03, 13.04, 13.05 or 13.06 – (a) when not drawing a trailer;	50	25	A motor cycle	
		(b) when drawing a trailer	45		25
2	A vehicle, not included in item 1 and not being a motor cycle, which is first used on or after 1st January 1968 – (a) when not drawing a trailer;	50	25		
		(b) when drawing a trailer manufactured on or after 1st January 1968;	50		25
		(c) when drawing a trailer manufactured before 1st January 1968	40		15
3	Goods vehicles and buses in each case first used on or after 15th August 1928 but before 1st January 1968 having an unladen weight exceeding 1,525 kg being – (a) rigid vehicles with 2 axles not constructed to form part of an articulated vehicle – (i) when not drawing a trailer;	45	20		
		(ii) when drawing a	40	15	
			40	15	

1 <i>Item</i>	2 <i>Class of vehicle</i>	3 <i>Efficiencies (%)</i>		4 <i>Exemptions</i>
		(a)	(b)	
	trailer; (b) other vehicles, including vehicles constructed to form part of an articulated vehicle, whether or not drawing a trailer			
4	Vehicles not included in items 1 to 3 – (a) having at least one means of operation applying to at least 4 wheels; (b) having 3 wheels and at least one means of operation applying to all 3 wheels and not being a motor cycle with sidecar attached – (i) when not drawing a trailer, (ii) in the case of a motor cycle when drawing a trailer; (c) other – (i) When not drawing a trailer, (ii) in the case of a motor cycle when drawing a trailer	50 40 40 30 30	25 25 25 25 25	(a) a bus; (b) an agricultural vehicle; (c) a vehicle constructed or adapted to form part of an articulated vehicle; (d) a heavy motor car which is a goods vehicle first used before 15th August 1928

- (6) A goods vehicle shall not be deemed to comply with the requirements of paragraph (5) unless it is capable of complying with those requirements both at the laden weight at which it is operating at any time and when its laden weight is equal to the design gross weight of the vehicle:

Provided that in the case of a goods vehicle drawing a trailer, references in this paragraph to laden weight refer to the combined laden weight of the drawing vehicle and the trailer and references to design gross weight are to be taken as references to design train weight.

- (7) A bus shall be deemed not to comply with the requirements of paragraph (5) unless it is capable of complying with those requirements both at its laden weight for the time being and at its relevant weight.
- (8) For the purposes of paragraph (7), the relevant weight –
- (a) in relation to a bus first used on or after 1st April 1982, is its maximum gross weight; and
- (b) in relation to a bus first used before that date, is the weight specified in paragraph (9).
- (9) The weight referred to in paragraph (8(b)) is –

$X + 63.5 (Y + Z)$ kg

where –

X is the unladen weight of that bus in kilograms;

Y is the number of passengers that the bus is constructed or adapted to carry seated in addition to the driver; and

Z is –

- (a) in the case of a PSV which is not an articulated bus and has a standing capacity exceeding 8 persons, the standing capacity minus 8;
 - (b) in the case of a PSV which is an articulated bus, the standing capacity; or
 - (c) in any other case, nil.
- (10) The brakes of every agricultural motor vehicle which is first used on or after 1st June 1986 and is not driven at more than 20 mph, and of every agricultural trailer manufactured on or before 1st December 1985 shall be capable of achieving a braking efficiency of not less than 25% when the weight of the vehicle is equal to the total maximum weights which the vehicle is designed to have.
- (11) Every vehicle or combination of vehicles specified in an item in column 2 of Table 2 shall be so maintained that its brakes are capable, without the assistance of stored energy, of holding it stationary on a gradient of at least the percentage specified in column 3 in that item.

TABLE 2

(Article 18(6))

1	2	3
<i>Item</i>	<i>Class of vehicle or combination</i>	<i>Percentage gradient</i>
1	A vehicle specified in item 1 of Table 1 – (a) when not drawing a trailer; (b) when drawing a trailer	16 12
2	A vehicle to which requirement 18 in Schedule 2 applies by virtue of Article 16	16
3	A vehicle, not included in item 1, drawing a trailer manufactured on or after 1st January 1968 and required, by Article 15 or 16, to be fitted with brakes	16

- (12) For the purpose of this Article the date of manufacture of a trailer which is a composite trailer shall be deemed to be the same as the date of manufacture of the semi-trailer which forms part of the composite trailer.
- (13) A vehicle which is subject to, and which complies with the requirements in, item 1 in Tables 1 and 2 shall not be treated as failing, by reason of its braking efficiency, to comply with Article 15 or with Community Directives 79/489, 85/647, 88/194 or 91/422 or ECE Regulation 13.03, 13.04, 13.05 or 13.06.
- (14) In this Article –
“PSV” means a Public Service Vehicle within the meaning of the 1935 Law;

“standing capacity” in relation to a PSV means the number of persons that can be carried standing pursuant to a determination by the Minister under Article 9 of the 1935 Law.

19 Application of brakes of trailers

Where a trailer is drawn by a motor vehicle the driver (or in the case of a locomotive one of the persons employed in driving or tending the locomotive) shall be in a position readily to operate any brakes required by this Order to be fitted to the trailer as well as the brakes of the motor vehicle unless a person other than the driver or in the case of a locomotive a person other than one of the persons employed in driving or tending the locomotive is in a position and competent efficiently to apply the brakes of the trailer:

Provided that this Article shall not apply to a trailer which –

- (a) in compliance with this Order, is fitted with brakes which automatically come into operation on the overrun of the trailer; or
- (b) is a broken-down vehicle being drawn, whether or not in consequence of a breakdown, in such a manner that it cannot be steered by its own steering gear.

C – WHEELS, SPRINGS, TYRES AND TRACKS

20 General requirements as to wheels and tracks

Every motor cycle and invalid carriage shall be a wheeled vehicle, and every other motor vehicle and every trailer shall be either a wheeled vehicle or a track-laying vehicle.

21 Diameter of wheels

All wheels of a wheeled vehicle which are fitted with tyres other than pneumatic tyres shall have a rim diameter of not less than 670 mm:

Provided that this Article does not apply to –

- (a) a motor vehicle first used on or before 2nd January 1933;
- (b) a trailer manufactured before 1st January 1933;
- (c) a wheel fitted to a motor car first used on or before 1st July 1936, if the diameter of the wheel inclusive of the tyre is not less than 670 mm;
- (d) a works truck or works trailer;
- (e) a refuse vehicle;
- (f) a pedestrian-controlled vehicle;
- (g) a mobile crane;
- (h) an agricultural trailed appliance;
- (i) a broken-down vehicle which is being drawn by a motor vehicle in consequence of the breakdown; or
- (j) an electrically propelled goods vehicle the unladen weight of which does not exceed 1,270 kg.

22 Springs and resilient material

- (1) Save as provided in paragraphs (3) and (4), every motor vehicle and every trailer shall be equipped with suitable and sufficient springs between each wheel and the frame of the vehicle.
- (2) Save as provided in paragraphs (3) and (4), in the case of a track-laying vehicle –
 - (a) resilient material shall be interposed between the rims of the weight-carrying rollers and the road surface so that the weight of the vehicle, other than that borne by any wheel, is supported by the resilient material; and
 - (b) where the vehicle is a heavy motor car, motor car, or trailer it shall have suitable springs between the frame of the vehicle and the weight-carrying rollers.
- (3) This Article does not apply to –
 - (a) a wheeled vehicle with an unladen weight not exceeding 4,070 kg and which is –
 - (i) a motor tractor any unsprung wheel of which is fitted with a pneumatic tyre,
 - (ii) a vehicle specially designed, and mainly used, for work on rough ground or unmade roads and every wheel of which is fitted with a pneumatic tyre and which is not driven at more than 20 mph,
 - (iii) a vehicle constructed or adapted for, and being used for, road sweeping and every wheel of which is fitted with either a pneumatic tyre or a resilient tyre and which is not driven at more than 20 mph;
 - (b) an agricultural motor vehicle which is not driven at more than 20 mph;
 - (c) an agricultural trailer, or an agricultural trailed appliance;
 - (d) a trailer used solely for the haulage of felled trees;
 - (e) a motor cycle;
 - (f) a mobile crane;
 - (g) a pedestrian-controlled vehicle all the wheels of which are equipped with pneumatic tyres;
 - (h) a road roller;
 - (i) a broken-down vehicle; or
 - (j) a vehicle first used on or before 1st January 1932.
- (4) Paragraph (1) and paragraph (2)(b) do not apply to a works truck or a works trailer.

23 Wheel loads

- (1) Subject to paragraph (2), this Article applies to –
 - (a) a semi-trailer with more than 2 wheels;
 - (b) a track-laying vehicle with more than 2 wheels; and
 - (c) any other vehicle with more than 4 wheels.
- (2) This Article does not apply to a road roller.

- (3) Save as provided in paragraphs (4) and (5), every vehicle to which this Article applies shall be fitted with a compensating arrangement which will ensure that under the most adverse conditions every wheel will remain in contact with the road and will not be subject to abnormal variations of load.
- (4) Paragraph (3) does not apply in respect of a steerable wheel on which the load does not exceed –
- (a) if it is a wheeled vehicle, 3,560 kg; and
 - (b) if it is a track-laying vehicle, 2,540 kg.
- (5) In the application of paragraph (3) to an agricultural motor vehicle, wheels which are in line transversely on one side of the longitudinal axis of the vehicle shall be regarded as one wheel.

24 Tyres

- (1) Save as provided in paragraph (2), every wheel of a vehicle of a class specified in an item in column 2 of the Table shall be fitted with a tyre of a type specified in that item in column 3 which complies with any conditions specified in that item in column 4.
- (2) The requirements referred to in paragraph (1) do not apply to a road roller and are subject, in the case of any item in the Table, to the exemption specified in that item in column 5.

TABLE

(Article 24(1))

(1) <i>Item</i>	(2) <i>Class of vehicle</i>	(3) <i>Type of tyre</i>	(4) <i>Conditions</i>	(5) <i>Exemptions</i>
1	Locomotives not falling in item 6	Pneumatic or resilient		
2	Motor tractors not falling in item 6	Pneumatic or resilient	No re-cut pneumatic tyre shall be fitted to any wheel of a vehicle with an unladen weight of less than 2,540 kg unless the diameter of the rim of the wheel is at least 405 mm	

(1)	(2)	(3)	(4)	(5)
<i>Item</i>	<i>Class of vehicle</i>	<i>Type of tyre</i>	<i>Conditions</i>	<i>Exemptions</i>
3	Heavy motor cars not falling in item 6	Pneumatic		The following, if every wheel not fitted with a pneumatic tyre is fitted with a resilient tyre – (a) a vehicle mainly used for work on rough ground; (b) a tower wagon; (c) a vehicle fitted with a turntable fire escape; (d) a refuse vehicle; (e) a works truck; (f) a vehicle first used before 3rd January 1933
4	Motor cars not falling in item 6	Pneumatic	No re-cut tyre shall be fitted to any wheel of a vehicle unless it is – (a) an electrically propelled goods vehicle; or (b) a goods vehicle with an unladen weight of at least 2,540 kg and the diameter of the rim is at least 405 mm	The following, if every wheel not fitted with a pneumatic tyre is fitted with a resilient tyre – (a) a vehicle mainly used for work on rough ground; (b) a refuse vehicle; (c) a works truck; (d) a vehicle with an unladen weight not exceeding – (i) 1,270 kg if electrically propelled, (ii) 1,020 kg in any other case (e) a tower wagon; (f) a vehicle fitted with a turntable fire escape; (g) a vehicle first used before 3rd January 1933
5	Motor cycle	Pneumatic	No re-cut tyre shall be fitted	The following, if every wheel not fitted with a pneumatic tyre is fitted with a resilient tyre – (a) a works truck; (b) a pedestrian-controlled vehicle
6	Agricultural motor	Pneumatic or resilient	The same as for item 2	The requirement in column 3 does not apply

(1)	(2)	(3)	(4)	(5)
<i>Item</i>	<i>Class of vehicle</i>	<i>Type of tyre</i>	<i>Conditions</i>	<i>Exemptions</i>
	vehicles which are not driven at more than 20 mph			<p>to a vehicle of which –</p> <p>(a) every steering wheel is fitted with a smooth-soled tyre which is not less than 6.0 mm wide where it touches the road; and</p> <p>(b) in the case of a wheeled vehicle, every driving wheel is fitted with a smooth-sole tyre which –</p> <p>(i) is not less than 150 mm wide if the unladen weight of the vehicle exceeds 3,050 kg, or 76 mm wide in any other case, and either</p> <p>(ii) is shod with diagonal crossbars not less than 76 mm wide or more than 20 mm thick extending the full breadth of the tyre and so arranged that the space between adjacent bars is not more than 76 mm; or</p> <p>(iii) is shod with diagonal Crossbars of resilient material not</p>

(1)	(2)	(3)	(4)	(5)
<i>Item</i>	<i>Class of vehicle</i>	<i>Type of tyre</i>	<i>Conditions</i>	<i>Exemptions</i>
				less than 60 mm wide extending the full breadth of the tyre and so arranged that the space between adjacent bars is not more than 76 mm
7	Trailers	Pneumatic	<p>Except in the case of a trailer mentioned in paragraph (d) of column 5, no recut tyre shall be fitted to any wheel of a trailer drawn by a heavy motor car if the trailer –</p> <p>(a) has an unladen weight not exceeding –</p> <p>(i) if it is a living van 2,040 kg;</p> <p>or</p> <p>(ii) in any other case, 1,020 kg;</p> <p>or</p> <p>(b) Is not constructed or adapted to carry any load, other than plant or other special appliance which is a permanent or essentially permanent fixture and has a gross weight not exceeding 2,290 kg</p>	<p>(a) an agricultural trailer manufactured before 1st December 1985;</p> <p>(b) an agricultural trailer appliance;</p> <p>(c) a trailer used to carry water for a road roller being used in connection with road works;</p> <p>(d) the following, if every wheel which is not fitted with a pneumatic tyre is fitted with a pneumatic tyre is fitted with a resilient tyre –</p> <p>(i) a works trailer;</p> <p>(ii) a refuse vehicle;</p> <p>(iii) a trailer drawn by a heavy motor car every wheel of which is not required to be fitted with a pneumatic tyre;</p> <p>(iv) a broken-down vehicle;</p> <p>or</p> <p>(v) a trailer</p>

(1) <i>Item</i>	(2) <i>Class of vehicle</i>	(3) <i>Type of tyre</i>	(4) <i>Conditions</i>	(5) <i>Exemptions</i>
				drawn by a vehicle which is not a heavy motor car or a motor car

- (3) Save as provided in paragraph (4) a wheel of a vehicle may not be fitted with a temporary use spare tyre unless either –
- the vehicle is a passenger vehicle (not being a bus) first used before 1st April 1987; or
 - the vehicle complies at the time of its first use with ECE Regulation 64 or Community Directive 92/23.
- (4) Paragraph (3) does not apply to a vehicle constructed or assembled by a person not ordinarily engaged in the trade or business of manufacturing vehicles of that description.

25 Tyre loads and speed ratings

- (1) Save as provided in paragraphs (3), (4) and (8) any tyre fitted to the axle of a vehicle –
- which is a class of vehicle specified in an item in column 2 of Table 1; and
 - in relation to which the date of first use is as specified in that item in column 3 of that Table;
- shall comply with the requirements specified in that item in column 4 of that Table.

TABLE 1
(Article 25(1))

1 <i>Item</i>	2 <i>Class of vehicle</i>	3 <i>Date of first use</i>	4 <i>Requirements</i>
1	Vehicles which are of one or more of the following descriptions, namely – (a) goods vehicles; (b) trailers; (c) buses; (d) vehicles of a class mentioned in column 2 in Table 3	Before 1st April 1991	The requirements of paragraphs (5) and (6)
2	Vehicles which are of one of the following descriptions – (a) goods vehicles; (b) trailers; (c) buses; (d) vehicles of a class	On or after 1st April 1991	The requirements of paragraphs (5), (6) and (7)

1	2	3	4
<i>Item</i>	<i>Class of vehicle</i>	<i>Date of first use</i>	<i>Requirements</i>
	mentioned in column 2 in Table 3, and do not fall within item 3		
3	Vehicles of a class mentioned in paragraph (2)	On or after 1st April 1991	The requirements of paragraph (5)

- (2) The classes of vehicle referred to in item 3 in column 2 of Table 1 are –
- (a) engineering plant;
 - (b) track-laying vehicles;
 - (c) vehicles equipped with tyres of speed category Q;
 - (d) works trucks; and
 - (e) motor vehicles with a maximum speed not exceeding 30 mph, not being vehicles of a class specified in –
 - (i) items 2 and 3 of Table 2; or
 - (ii) paragraph (8) or sub-paragraphs (a) to (d); or trailers while being drawn by such vehicles.
- (3) Paragraph (1) shall not apply to any tyre fitted to the axle of a vehicle if the vehicle is –
- (a) broken-down or proceeding to a place where it is to be broken up; and
 - (b) being drawn by a motor vehicle at a speed not exceeding 20 mph.
- (4) Where in relation to any vehicle first used on or after 1st April 1991 a tyre supplied by a manufacturer for the purposes of tests or trials of that tyre is fitted to an axle of that vehicle, paragraph (7) shall not apply to that tyre while it is being used for those purposes.
- (5) The requirements of this paragraph are that the tyre, as respects strength, shall be designed and manufactured adequately to support the maximum permitted axle weight for the axle.
- (6) The requirements of this paragraph are that the tyre shall be designed and manufactured adequately to support the maximum permitted axle weight for the axle when the vehicle is driven at the speed shown in column 3 in Table 2 in the item in which the vehicle is described in column 2 (the lowest relevant speed being applicable to a vehicle which is described in more than one item).

TABLE 2
(Article 25(6))

1 <i>Item</i>	2 <i>Class of vehicle</i>	3 <i>Speed (mph)</i>	4 <i>Variation to the load-capacity index expressed as a percentage</i>	
			Tyres marked in accordance with ECE Regulation 30, 30.01 or 30.02 and relevant car tyres	Tyres marked in accordance with ECE Regulation 54 and relevant commercial vehicle tyres
1	A vehicle of a class for which maximum speeds are prescribed by Schedule 2 to the Law other than an agricultural motor vehicle	The highest speed so prescribed	Single wheels: None Dual wheels 95.5%	None
2	An electrically propelled vehicle used as a multi-stop local collection and delivery vehicle and having a maximum speed of not more than 25 mph	The maximum speed of the vehicle	None	150%
3	An electrically propelled vehicle used as a multi-stop collection and delivery vehicle and having a maximum speed of more than 25 mph and not more than 40 mph	The maximum speed of the vehicle	None	130%

1	2	3	4	
<i>Item</i>	<i>Class of vehicle</i>	<i>Speed (mph)</i>	<i>Variation to the load-capacity index expressed as a percentage</i>	
4	An electrically propelled vehicle used only within a radius of 25 miles from the permanent base at which it is normally kept and having a maximum speed of more than 40 mph and not more than 50 mph	The maximum speed of the vehicle	None	115%
5	A bus or coach	50	None	110%
6	A restricted speed vehicle	50	None	The relevant % variation specified in Annex 8 to ECE Regulation 54 or Appendix 8 to Annex II to Community Directive 92/23 Tyres marked in accordance with ECE Regulation 54
7	A low platform trailer, an agricultural motor vehicle, an agricultural motor vehicle, an agricultural trailer, an agricultural trailed appliance or an agricultural trailed appliance conveyor	40	None	The relevant % variation specified in Annex 8 to ECE Regulation 54 or Appendix 8 to Annex II to Community Directive 92/23 Tyres marked in accordance with ECE Regulation 30, 30.01 or 30.02
8	A public works vehicle	40	None	115%
9	A multi-stop local collection and delivery vehicle if not falling within the class of vehicle described in items 2 or 3 above	40	None	115%

1	2	3	4	
<i>Item</i>	<i>Class of vehicle</i>	<i>Speed (mph)</i>	<i>Variation to the load-capacity index expressed as a percentage</i>	
10	A light trailer or any trailer equipped with tyres of speed category F or G	60	Single wheels: 110% Dual wheels: 105%	The relevant variation specified in Annex 8 to ECE Regulation 54 or Appendix 8 to Annex II to Community Directive 92/23
11	A trailer not falling in items 6 – 10	60	Single wheels: none Dual wheels: 95.5%	None
12	A motor vehicle not falling in items 1 – 11	70	Single wheels: None Dual wheels: 95.5%	None

- (7) The requirement of this paragraph is that the tyre when first fitted to the vehicle was marked with a designated approval mark or complied with the requirements of ECE Regulation 30, 30.01, 30.02 or 54, but this requirement shall not apply to a retreaded tyre.
- (8) The requirements of paragraphs (6) and (7) shall not apply to any tyre fitted to the axle of a vehicle of a class specified in an item in column 2 of Table 3 while the vehicle is being driven or drawn at a speed not exceeding that specified in that item in column 3 of that Table.

TABLE 3

(Article 25(8))

1	2	3
<i>Item</i>	<i>Class of vehicle</i>	<i>Speed (mph)</i>
1	Agricultural motor vehicles	20
2	Agricultural trailers	20
3	Agricultural trailed appliances	20
4	Agricultural trailed appliance conveyors	20
5	Works trailers	18

- (9) Paragraph (10) applies where a tyre fitted to the axle of the vehicle –
- bears a speed category symbol and load-capacity index, being marks that were moulded on to or into the tyre at the time that it was manufactured;
 - is designed and manufactured so as to be capable of operating safely at the speed and load indicated by those marks; and
 - is designed so as to be capable of being fitted to the axle of a vehicle of a class specified in item 1, 2, 3 or 4 in column 2 of Table 3.
- (10) In the circumstances mentioned in paragraph (9), paragraph (7) shall not apply to the tyre if –
- the vehicle is being driven or drawn at a speed that does not exceed the speed indicated by the speed category symbol; and

- (b) the load on the tyre does not exceed the load indicated by the load capacity index.
- (11) A vehicle of a class described in column 2 in Table 2 first used on or after 1st April 1991 shall not be used on a road –
- (a) in the case where there is no entry in column 4 specifying a variation to the load-capacity index expressed as a percentage, if the load applied to any tyre fitted to the axle of the vehicle exceeds that indicated by the load-capacity index; or
- (b) in the case where there is such an entry in column 4, if the load applied to any tyre fitted to the axle of the vehicle exceeds the variation to the load-capacity index expressed as a percentage.
- (12) In this Article –
- “bus or coach” means an omnibus or char-à-banc used in the provision of a service licensed under the 1935 Law;
- “designated approval mark” means the marking designated as an approval mark by regulation 5 of the Approval Marks Regulations and shown at item 33 in Schedule 4 to those Regulations (that item being a marking relating to Community Directive 92/23);
- “dual wheels” means 2 or more wheels which are to be regarded as one wheel by virtue of Article 1(10) in the circumstances specified in that paragraph;
- “load-capacity index” has the same meaning as in paragraph 2.28 of Annex II to Community Directive 92/23 or paragraph 2.29 or ECE Regulation 30.02 or paragraph 2.27 of ECE Regulation 54;
- “multi-stop local collection and delivery vehicle” means a motor vehicle or trailer used for multi-stop collection and delivery services to be used only within Jersey;
- “single wheels” means wheels which are not dual wheels; and
- “speed category” has the same meaning as in paragraph 2.29 of Annex II to Community Directive 92/23 or paragraph 2.28 of ECE Regulation 54.
- (13) For the purposes of this Article, a tyre is a “relevant car tyre” if –
- (a) it has been marked with a designated approval mark; and
- (b) the first 2 digits of the approval number comprised in the mark are “02”.
- (14) For the purposes of this Article, a tyre is a “relevant commercial vehicle tyre” if –
- (a) it has been marked with a designated approval mark; and
- (b) the first 2 digits of the approval number comprised in the mark are “00”.
- (15) In this Article any reference to the first use shall, in relation to a trailer, be construed as a reference to the date which is 6 months after the date of manufacture of the trailer.

26 Mixing of tyres

- (1) Save as provided in paragraph (5), pneumatic tyres of different types of structure shall not be fitted to the same axle of a wheeled vehicle.

- (2) Save as provided in paragraph (3) or (5), a wheeled motor vehicle having only 2 axles each of which is equipped with one or 2 single wheels shall not be fitted with –
- (a) a diagonal-ply tyre or a bias-belted tyre on its rear axle if a radial-ply is fitted on its front axle; or
 - (b) a diagonal-ply tyre on its rear axle if a bias-belted tyre is fitted on the front axle.
- (3) Paragraph (2) does not apply to a vehicle to an axle of which there are fitted wide tyres not specially constructed for use on engineering plant or to a vehicle which has a maximum speed not exceeding 30 mph.
- (4) Save as provided in paragraph (5), pneumatic tyres fitted to –
- (a) the steerable axles of a wheeled vehicle; or
 - (b) the driven axle of a wheeled vehicle, not being steerable axles,
- shall all be of the same type of structure.
- (5) Paragraphs (1), (2) and (4) do not prohibit the fitting of a temporary use spare tyre to a wheel of a passenger vehicle (not being a bus).
- (6) In this Article –
- “axle” includes –
- (a) 2 or more sub axles which are fitted on opposite sides of the longitudinal axis of the vehicle so as to form –
 - (i) a pair in the case of 2 stub axles, and
 - (ii) pairs in the case of more than 2 stub axles; and
 - (b) a single stub axle which is not one of a pair;

“bias-belted tyre” means a pneumatic tyre, the structure of which is such that the ply cords extend to the bead so as to be laid at alternate angles of substantially less than 90 degrees to the peripheral line of the tread, and are constrained by a circumferential belt comprising 2 or more layers of substantially inextensible cord material laid at alternate angles smaller than those of the ply cord structure;

“diagonal-ply tyre” means a pneumatic tyre, the structure of which is such that the ply cords extend to the bead so as to be laid at alternate angles of substantially less than 90 degrees to the peripheral line of the tread, but not being a bias-belted tyre;

“driven axle” means an axle through which power is transmitted from the engine of a vehicle to the wheels on that axle;

“radial-ply tyre” means a pneumatic tyre, the structure of which is such that the ply cords extend to the bead so as to be laid at an angle of substantially 90 degrees to the peripheral line of the tread, the ply cord structure being stabilized by a substantially inextensible circumferential belt;

“stub axle” means an axle on which only one wheel is mounted; and

“type of structure”, in relation to a tyre, means a type of structure of a tyre of a kind defined in this paragraph.

27 Condition and maintenance of tyres

- (1) Save as provided in paragraphs (2), (3) and (4), a wheeled motor vehicle or trailer a wheel of which is fitted with a pneumatic tyre shall not be used on a road, if –
- (a) the tyre is unsuitable having regard to the use to which the motor vehicle or trailer is being put or to the types of tyres fitted to its other wheels;
 - (b) the tyre is not so inflated as to make it fit for the use to which the motor vehicle or trailer is being put;
 - (c) the tyre has a cut in excess of 25 mm or 10% of the section width of the tyre, whichever is the greater, measured in any direction on the outside of the tyre and deep enough to reach the ply or cord;
 - (d) the tyre has any lump, bulge or tear caused by separation or partial failure of its structure;
 - (e) the tyre has any of the ply or cord exposed;
 - (f) the base of any groove which showed in the original tread pattern of the tyre is not clearly visible;
 - (g) either –
 - (i) the grooves of the tread pattern of the tyre do not have a depth of at least 1 mm throughout a continuous band measuring at least $\frac{3}{4}$ of the breadth of the tread and round the entire outer circumference of the tyre, or
 - (ii) if the grooves of the original tread pattern of the tyre did not extend beyond $\frac{3}{4}$ of the breadth of the tread, any groove which showed in the original tread pattern does not have a depth of at least 1 mm; or
 - (h) the tyre is not maintained in such condition as to be fit for the use to which the vehicle or trailer is being put or has a defect which might in any way cause damage to the surface of the road or damage to persons on or in the vehicle or to other persons using the road.
- (2) Paragraph (1) does not prohibit the use on a road of a motor vehicle or trailer by reason only of the fact that a wheel of the vehicle or trailer is fitted with a tyre which is deflated or not fully inflated and which has any of the defects described in paragraph (1)(c), (d) or (e), if the tyre and the wheel to which it is fitted are so constructed as to make the tyre in that condition fit for the use to which the motor vehicle or trailer is being put and the outer sides of the wall of the tyre are so marked as to enable the tyre to be identified as having been constructed to comply with the requirements of this paragraph.
- (3) Paragraph (1)(a) does not prohibit the use on a road of a passenger vehicle (not being a bus) by reason only of the fact that a wheel of the vehicle is fitted with a temporary use spare tyre.
- (4)
- (a) Nothing in paragraph (1)(a) to (g) applies to –
 - (i) an agricultural motor vehicle that is not driven at more than 20 mph,
 - (ii) an agricultural trailer,
 - (iii) an agricultural trailed appliance, or

- (iv) a broken-down vehicle or a vehicle proceeding to a place where it is to be broken up, being drawn, in either case, by a motor vehicle at a speed not exceeding 20 mph;
 - (b) nothing in paragraph (1)(f) and (g) applies to –
 - (i) a motor tricycle the unladen weight of which does not exceed 102 kg and which has a maximum speed of 12 mph, or
 - (ii) a pedestrian-controlled works truck;
 - (c) nothing in paragraph (1)(g) applies to a motor cycle with an engine capacity which does not exceed 50 cc;
 - (d) paragraph (1)(f) and (g) shall not apply to the vehicles specified in sub-paragraph (e) but such vehicles shall comply with the requirements specified in sub-paragraph (f);
 - (e) the vehicles mentioned in sub-paragraph (d) are –
 - (i) passenger vehicles other than motor cycles constructed or adapted to carry no more than 8 seated passengers in addition to the driver,
 - (ii) goods vehicles with a maximum gross weight which does not exceed 3,500 kg, and
 - (iii) light trailers not falling within clause (ii),
first used on or after 3rd January 1933;
 - (f) the requirements referred to in sub-paragraph (d) are that the grooves of the tread pattern of every tyre fitted to the wheels of a vehicle mentioned in sub-paragraph (e) shall be of a depth of at least 1.6 mm throughout a continuous band comprising the central $\frac{3}{4}$ of the breadth of tread and round the entire outer circumference of the tyre.
- (5) A re-cut pneumatic tyre shall not be fitted to any wheel of a motor vehicle or trailer if –
- (a) its ply or cord has been cut or exposed by the re-cutting process; or
 - (b) it has been wholly or partially re-cut in a pattern other than the manufacturer's re-cut tread pattern.
- (6) (a) In this Article –
- “breadth of tread” means the breadth of that part of the tyre which can contact the road under normal conditions of use measured at 90 degrees to the peripheral line of the tread;
- “original tread pattern” means in the case of –
- (i) a re-treaded tyre, the tread pattern of the tyre immediately after the tyre was re-treaded,
 - (ii) a wholly re-cut tyre, the manufacturer's recut tread pattern,
 - (iii) a partially recut tyre, on that part of the tyre which has been re-cut, the manufacturer's re-cut tread pattern, and on the other part, the tread pattern of the tyre when new, and
 - (iv) any other tyre, the tread patter of the tyre when the tyre was new;

“tie-bar” means any part of the tyre moulded in the tread pattern of the tyre for the purpose of bracing 2 or more features of such tread pattern;

“tread pattern” means the combination of plain surfaces and grooves extending across the breadth of the tread and round the entire outer circumference of the tyre but excludes any –

- (i) tie bars or tread wear indicators,
- (ii) features which are designed to wear substantially before the rest of the pattern under normal conditions of use, and
- (iii) other minor features;

“tread wear indicator” means any bar, not being a tie-bar, projecting from the base of a groove of the tread pattern of a tyre and moulded between 2 or more features of the tread pattern of a tyre for the purpose of indicating the extent of the wear of such tread pattern;

- (b) the references in paragraph (1)(g)(i) to grooves are references –
 - (i) if a tyre has been re-cut, to the grooves of the manufacturer’s re-cut tread pattern; and
 - (ii) if a tyre has not been re-cut, to the grooves which showed when the tyre was new;
- (c) a reference in this Article to first use shall, in relation to a trailer, be construed as a reference to the date which is 6 months after the date of manufacture of the trailer.

28 Tracks

- (1) Every part of every track of a track-laying vehicle which comes into contact with the road shall be flat and have a width of not less than 12.5 mm.
- (2) The area of the track which is in contact with the road shall not at any time be less than 225 cm² in respect of every 1,000 kg of the total weight which is transferred to the road by the tracks.
- (3) The tracks of a vehicle shall not have any defect which might damage the road or cause damage to any person on or in the vehicle or using the road, and shall be properly adjusted and maintained in good and efficient working order.

D – STEERING

29 Maintenance of steering gear

All steering gear fitted to a motor vehicle shall at all times while the vehicle is used on a road be maintained in good and efficient working order and be properly adjusted.

*E – VISION***30 View to the front**

- (1) Every motor vehicle shall be so designed and constructed that the driver thereof while controlling the vehicle can at all times have a full view of the road and traffic ahead of the motor vehicle.
- (2) Instead of complying with the requirement of paragraph (1) a vehicle may comply with Community Directive 77/649, 81/643, 88/366, 90/630 or, in the case of an agricultural motor vehicle, 79/1073.
- (3) All glass or other transparent material fitted to a motor vehicle shall be maintained in such condition that it does not obscure the vision of the driver while the vehicle is being driven on a road.

31 Glass to be fitted to certain vehicles

- (1) This Article applies to a motor vehicle which is –
 - (a) a wheeled vehicle, not being a caravan, first used before 1st June 1978;
 - (b) a caravan first used before 1st September 1978; or
 - (c) a track-laying vehicle.
- (2) The glass fitted to any window specified in an item in column 3 of the Table of a vehicle of a class specified in that item in column 2 shall be safety glass.

TABLE

(Article 31(2))

1	2	3
<i>Item</i>	<i>Class of vehicle</i>	<i>Windows</i>
1	Wheeled vehicles first used on or after 1st January 1959 being passenger vehicles or dual-purpose vehicles	Windscreens and all outside windows
2	Wheeled vehicles first used on or after 1st January 1959, being goods vehicles (other than dual-purpose vehicles) locomotives or motor tractors	Windscreens and all windows in front of and on either side of the driver's seat
3	Wheeled vehicles not mentioned in item 1 or 2	Windscreens and windows facing to the front on the outside, except glass fitted to the upper decks of a double-decked vehicle
4	Track-laying vehicles	Windscreens and windows facing to the front

- (3) For the purposes of this Article any windscreen or window at the front of the vehicle the inner surface of which is at an angle exceeding 30 degrees to the longitudinal axis of the vehicle shall be deemed to face to the front.

- (4) In this Article and in Article 32 –
- “caravan” means a trailer which is constructed (and not merely adapted) for human habitation;
- “designated approval mark” means the marking designed as an approval mark by regulation 5 of the Approval Marks Regulations and shown at item 31 or 32 in Schedule 4 to those Regulations (those items being markings relating to Community Directive 92/22); and
- “safety glass” means glass so constructed or treated that if fractured it does not fly into fragments likely to cause severe cuts.
- (5) Paragraph (2) does not apply to glass which is legally and permanently marked with a designated approval mark.

32 Glass to be fitted to other vehicles

- (1) This Article applies to –
- a caravan first used on or after 1st September 1978; and
 - a wheeled motor vehicle and a wheeled trailer, not being a caravan, first used on or after 1st June 1978.
- (2) Save as provided in paragraphs (3) to (9) the windows specified in column 2 of Table 1 in relation to a vehicle of a class specified in that column shall be constructed of the material specified in column 3 of that Table.

TABLE 1
(Article 32(2))

1	2	3
<i>Item</i>	<i>Window</i>	<i>Materials</i>
1	Windscreens and other windows wholly or partly on either side of the driver’s seat fitted to motor vehicles first used on or after 1st April 1985	Specified safety glass (1980)
2	Windscreens and other windows wholly or partly on either side of the driver’s seat fitted to a motor vehicle first used before 1st April 1985	Specified safety glass, or specified safety glass (1980)
3	All other windows	Specified safety glass, specified safety glass (1980), or safety glazing

- (3) The windscreens and all other windows of security vehicles or vehicles being used for police purposes shall not be subject to the requirements specified in paragraph (2), but shall be constructed of either safety glass or safety glazing.
- (4) The windscreens of motor cycles not equipped with an enclosed compartment for the driver or for a passenger shall not be subject to the requirements specified in paragraph (2), but shall be constructed of safety glazing.

- (5) Any windscreens or other windows which are wholly or partly in front of or on either side of the driver's seat, and which are temporarily fitted to motor vehicles to replace any windscreens or other windows which have broken, shall –
- (a) be constructed of safety glazing; and
 - (b) be fitted only while the vehicles are being driven or towed either to premises where new windscreens or other windows are to be permanently fitted to replace the windscreens or other windows which have broken, or to complete the journey in the course of which the breakage occurred.
- (6) Windows forming all or part of a screen or door in the interior of a bus first used on or after 1st April 1988, shall be constructed either of safety glazing or of specified safety glass (1980).
- (7) Windows being –
- (a) windows (other than windscreens) of motor vehicles being engineering plant, industrial tractors, agricultural motor vehicles (other than agricultural motor vehicles first used on or after 1st June 1986) and driven at more than 20 mph which are wholly or partly in front or on either side of the driver's seat;
 - (b) windows of the upper deck of a double-decked bus; or
 - (c) windows in the roof of a vehicle,
- shall be constructed of either specified safety glass, specified safety glass (1980) or safety glazing.
- (8) In the case of motor vehicles and trailers which have not at any time been fitted with permanent windows and which are being driven or towed to a place where permanent windows are to be fitted, any temporary windscreens and any other temporary windows shall be constructed of either specified safety glass, specified safety glass (1980) or safety glazing.
- (9) No requirement in this Article that a windscreen or other window shall be constructed of specified safety glass or of specified safety glass (1980) shall apply to a windscreen or other window which is –
- (a) manufactured in France;
 - (b) marked with a marking consisting of letters “TP GS” or “TP GSE”; and
 - (c) fitted to a vehicle first used before 1st October 1986.
- (10) Save as provided in paragraph (11), the windscreens or other windows constructed in accordance with this Article of specified safety glass, specified safety glass (1980) or safety glazing and specified in column 3 of Table 2 in relation to a vehicle of a class specified in column 2 of that Table shall have a visual transmission for light of not less than the percentage specified in relation to those windows in column 4 when measured perpendicular to the surface in accordance with the procedure specified in a document specified in relation to those windows in column 5.

TABLE 2
(Article 32(10))

1	2	3	4	5
<i>Item</i>	<i>Class of vehicles</i>	<i>Windows</i>	<i>Percentage</i>	<i>Documents specifying procedure</i>
1	Motor vehicles first used before 1st April 1985	All windows	70	British Standard Specification No. 857 or No. 5282
2	Motor vehicles first used on or after 1st April 1985 and trailers	(a) Wind-screens (b) All other windows	75 70	The documents mentioned in sub-paragraph (a), (b) or (c) of the definition in paragraph (16) of “specified safety glass (1980)”

- (11) Paragraph (10) does not apply to –
- (a) any part of any windscreen which is outside the vision reference zone;
 - (b) windows through which the driver when in the driver’s seat is unable at any time to see any part of the road on which the vehicle is waiting or proceeding;
 - (c) windows in any motor ambulance which are not wholly or partly in front or on either side of any part of the driver’s seat; or
 - (d) windows in any bus, goods vehicle, locomotive, or motor tractor other than windows which –
 - (i) are wholly or partly in front of or on either side of any part of the driver’s seat,
 - (ii) face the rear of the vehicle, or
 - (iii) form the whole or part of a door giving access to or from the exterior of the vehicle.
- (12) For the purposes of this Article any window at the rear of the vehicle is deemed to face the rear of the vehicle if the inner surface of such window is at an angle exceeding 30 degrees to the longitudinal axis of the vehicle.
- (13) Paragraphs (2), (6), (7) and (8) do not apply to a window which is legibly and permanently marked with a designated approval mark.
- (14) Paragraph (10) does not apply to a window if –
- (a) it is a window to which paragraph (15) applies and is legibly and permanently marked with a designated approval mark which does not comprise the Roman numeral “V” (other than as part of the combination “VI”); or
 - (b) it is not a window to which paragraph (15) applies and is legibly and permanently marked with a designated approval mark.
- (15) This paragraph applies to a side or rear window if –
- (a) any part of it is on either side of or forward of the driver’s seat; or

- (b) any part of it within the driver's indirect field of view obtained by means of the mirror or mirrors which are required to be fitted by Article 33 when such mirrors are properly adjusted;

and for the purposes of this paragraph a mirror shall not be regarded as being required to be fitted by Article 33 if, were it to be removed, the vehicle would nevertheless meet the requirements of Article 33.

- (16) In this Article, unless the context otherwise requires –

“British Standard Specification No. 857” means the British Standard Specification for Safety Glass for Land Transport published on 30th June 1967 under the number BS 857 as amended by Amendment Slip No. 1 published on 15th January 1973 under the number AMD 1088;

“British Standard Specification No. 5282” means the British Standard Specification for Road Vehicle Safety Glass published in December 1975 under the number BS 5282 as amended by Amendment Slip No. 1 published on 31st March 1976 under the number AMD 1927, and as amended by Amendment Slip No. 2 published on 31st January 1977 under the number AMD 2185;

“British Standard Specification BS AU 178” means the British Standard Specification for Road Vehicle Safety Glass published on 28th November 1980 under the number BS AU 178;

“designated approval mark” means –

- (a) in relation to a windscreen, the marking designated as an approval mark by regulation 5 of the Approval Marks Regulations and shown at item 31 in Schedule 4 to those Regulations; and
- (b) in relation to a window other than a windscreen, the markings designated as approval marks by regulation 5 of those Regulations and shown at item 32 in Schedule 4 to those Regulations;

“safety glazing” means material (other than glass) which is so constructed or treated that if fractured it does not fly into fragments likely to cause severe cuts;

“security vehicle” means a motor vehicle which is constructed (and not merely adapted) for the carriage of either –

- (a) persons who are likely to require protection from any criminal offence involving violence; or
- (b) dangerous substances, bullion, money, jewellery, documents or other goods or burden which, by reason of their nature or value, are likely to require protection from any criminal offence;

“specified safety glass” means glass complying with the requirements of either –

- (a) British Standard Specification No. 857 (including the requirements as to marking); or
- (b) British Standard Specification No. 5282 (including the requirements as to marking);

“specified safety glass (1980)” means glass complying with the requirements of either –

- (a) the British Standard Specification for Safety Glass for Land Transport published on 30th June 1967 under the number BS 857 as amended by

Amendment Slip No. 1 published on 15th January 1973 under the number AMD 1088, Amendment Slip No. 2 published on 30th September 1980 under the number AMD 3402, Amendment Slip No. 4 published on 15th February 1981 under the number AMD 3548 (including the requirements as to markings);

- (b) British Standard Specification BS AU 178 (including the requirements as to marking); or
- (c) ECE Regulation 43 (including the requirements as to marking);

“vision reference zone” means either –

- (a) the primary vision area as defined in British Standard Specification No. 857;
- (b) Zone 1, as defined in British Standard Specification No. 5282;
- (c) Zone B (as regards passenger vehicles other than buses) and Zone 1 (as regards all other vehicles) as defined in British Standard Specification BS AU 178 and ECE Regulation 43; and

“windscreen” includes a windshield.

33 Mirrors

- (1) Save as provided in paragraphs (5) and (6), a motor vehicle (not being a road roller) which is of a class specified in an item in column 2 of the Table shall be fitted with such mirror or mirrors, if any, as are specified in that item in column 3; and any mirror which is fitted to such a vehicle shall, whether or not it is required to be fitted, comply with the requirements, if any, specified in that item in column 4.
- (2) Save as provided in paragraph (5), each exterior mirror with which a vehicle is required to be fitted in accordance with item 2 or 6 of the Table shall, if the vehicle has a technically permissible maximum weight (as mentioned in Annex I to Community Directive 71/127) exceeding 3,500 kg, be a Class II mirror (as described in that Annex) and shall in any other case be a Class II or a Class III mirror (as described in that Annex).
- (3) Save as provided in paragraph (5), in the case of a wheeled motor vehicle described in item 1, 2, 7 or 8 of the Table which is first used on or after 1st April 1969 the edges of any mirror fitted internally shall be surrounded by some material such as will render it unlikely that severe cuts would be caused if the mirror or that material were struck by any occupant of the vehicle.
- (4) Save as provided in paragraph (5), in the case of a motor vehicle falling within paragraph (a) in column 4 of items 1 and 5, or within item 6, of the Table –
 - (a) each mirror shall be fixed to the vehicle in such a way that it remains steady under normal driving conditions;
 - (b) each exterior mirror on a vehicle fitted with windows and a windscreen shall be visible to the driver, when in the driver’s driving position, through a side window or through the portion of the windscreen which is swept by the windscreen wiper;
 - (c) where the bottom edge of an exterior mirror is less than 2 m above the road surface when the vehicle is laden, that mirror shall not project more than 20 cm beyond the overall width of the vehicle or, in a case where the vehicle is

drawing a trailer which has an overall width greater than that of the drawing vehicle, more than 20 cm beyond the overall width of the trailer;

- (d) each interior mirror shall be capable of being adjusted by the driver when in the driver's driving position; and
- (e) except in the case of a mirror which, if knocked out of its alignment, can be returned to its former position without needing to be adjusted, each exterior mirror on the driver's side of the vehicle shall be capable of being adjusted by the driver when in the driver's driving position, but this requirement shall not prevent such a mirror from being locked into position from the outside of the vehicle.

TABLE

(Article 33(1))

1	2	3	4
<i>Item</i>	<i>Class of vehicle</i>	<i>Mirrors to be fitted</i>	<i>Requirements to be complied with by any mirrors fitted</i>
1	<p>A motor vehicle which is –</p> <ul style="list-style-type: none"> (a) drawing a trailer, if a person is carried on the trailer so that the person has an uninterrupted view to the rear and has an efficient means of communicating to the driver the effect of signals given by the drivers of other vehicles to the rear; (b)(i) a works truck; (ii) a track-laying agricultural motor vehicle; and (iii) a wheeled agricultural vehicle first used before 1st June 1978, <p>if, in each case, the driver can easily obtain a view to the rear;</p> <ul style="list-style-type: none"> (c) a pedestrian-controlled vehicle; (d) a chassis being driven from the place where it has been 	No requirements	<ul style="list-style-type: none"> (a) if the vehicle is a wheeled vehicle first used on or after 1st June 1978, Item 2 of Annex I to Community Directive 71/127 or 79/795 or Annex II to Community Directive 86/562 or paragraphs 4 to 8 of ECE Regulation 46.01 and paragraph (4); (b) in other cases, none, except as specified in paragraph (3)

1	2	3	4
<i>Item</i>	<i>Class of vehicle</i>	<i>Mirrors to be fitted</i>	<i>Requirements to be complied with by any mirrors fitted</i>
	<p>manufactured to the place where it is to receive a vehicle body; or</p> <p>(e) an agricultural motor vehicle which has an unladen weight exceeding 7370 kg and which –</p> <p>(i) is a track-laying vehicle, or</p> <p>(ii) is a wheeled vehicle first used before 1st June 1978</p>		
2	<p>A motor vehicle, not included in item 1, which is –</p> <p>(a) a wheeled locomotive or a wheeled motor tractor first used in either case on or after 1st June 1978;</p> <p>(b) an agricultural motor vehicle, not being a track-laying vehicle with an unladen weight not exceeding 7,370 kg (which falls in item 8) or a wheeled agricultural motor vehicle first used after 1st June 1986 which is driven at more than 20 mph (which falls in item (6)); or</p> <p>(c) a works truck</p>	At least one mirror fitted externally on the offside	None except as specified in paragraphs (2) and (3)

1	2	3	4
<i>Item</i>	<i>Class of vehicle</i>	<i>Mirrors to be fitted</i>	<i>Requirements to be complied with by any mirrors fitted</i>
3	A wheeled motor vehicle not included in item 1 first used on or after 1st April 1983 which is – (a) a bus; or (b) a goods vehicle with a maximum gross weight exceeding 3,500 kg (not being an agricultural motor vehicle or one which is not driven at more than 20 mph) other than a vehicle described in item 4	Mirrors complying with item 3 of Annex I to Community Directive 79/795 or with paragraph 2.1 of Annex III to Community Directive 86/562 or 88/321 or paragraph 16.2.1 of ECE Regulation 46.01 or, except in the case of a goods vehicle first used on or after 1st April 1985, mirrors as required in the entry in this column in item 6	Item 2 of Annex I to Community Directive 71/127 or 79/795 or Annex II to Community Directive 86/562 or 88/321 or paragraphs 4 to 8 of ECE Regulation 46.01
4	A goods vehicle not being an agricultural motor vehicle with a maximum gross weight exceeding 12,000 kg which is first used on or after 1st October 1988	Mirrors complying with paragraph 2.1 of Annex III to Community Directive 86/562 or 88/321 or paragraph 16.2.1 of ECE Regulation 46.01	Annex II to Community Directive 86/562 or 88/321 or paragraphs 4 to 8 of ECE Regulation 46.01
5	A motor cycle with or without a sidecar attached	No requirement	(a) if the vehicle is first used on or after 1st October 1978, item 2 of Annex I to Community Directive 71/127, 79/795 or 80/780 or Annex II to Community Directive 86/562 to 88/321 or paragraphs 4 to 8 of ECE Regulation 46.01 and paragraph (4); (b) in other cases, none
6	A wheeled motor vehicle not	(i) at least one	Item 2 of Annex I to

1	2	3	4
<i>Item</i>	<i>Class of vehicle</i>	<i>Mirrors to be fitted</i>	<i>Requirements to be complied with by any mirrors fitted</i>
	in items 1 to 5, which is first used on or after 1st June 1978 (or, in the case of a Ford Transit motor car, 10th July 1978)	<p>mirror fitted externally on the offside of the vehicle, and</p> <p>(ii) at least one mirror fitted internally, unless a mirror so fitted would give the driver no view to the rear of the vehicle, and</p> <p>(iii) at least one mirror fitted externally on the nearside of the vehicle unless a mirror which gives the driver an adequate view to the rear is fitted internally</p>	Community Directive 71/127 or 79/795 or Annex II to Community Directive 86/562 or 88/321 or paragraphs 4 to 8 of ECE Regulation 46.01 and paragraphs (2) and (4)
7	A wheeled motor vehicle, not in items 1 to 5, first used before 1st June 1978 (or in the case of a Ford Transit motor car, 10th July 1978) and a track-laying motor vehicle which is not an agricultural motor vehicle first used on or after 1st January 1958, which in either case is – (a) a bus; (b) a dual-purpose vehicle; or (c) a goods vehicle	At least one mirror fitted externally on the offside of the vehicle and at least one mirror fitted either internally or externally on the nearside of the vehicle	None, except as specified in paragraph (3)
8	A motor vehicle, whether wheeled or track-laying, not in items 1 to 7	At least one mirror fitted internally or externally	None, except as specified in paragraph (3)

(5) Instead of complying with paragraphs (1) to (4) a vehicle may comply –

- (a) if it is a goods vehicle with a maximum gross weight exceeding 3,500 kg first used on or after 1st April 1985 and before 1st August 1989, with

Community Directive 79/795, 85/205, 86/562 or 88/321 or ECE Regulation 46.01;

- (b) if it is a goods vehicle first used on or after 1st August 1989 –
 - (i) in the case of a vehicle with maximum gross weight exceeding 3,500 kg but not exceeding 12,000 kg, with Community Directive 79/795, 85/205, 86/562 or 88/321 or ECE Regulation 46.01, and
 - (ii) in the case of a vehicle with maximum gross weight exceeding 12,000 kg, with Community Directive 85/205, 86/562 or 88/321 or ECE Regulation 46.01; and
- (c) if it is an agricultural motor vehicle, with Community Directive 71/127, 74/346, 79/795, 85/205, 86/562 or 88/321 or ECE Regulation 46.01;
- (d) if it is a motor cycle with or without a side-car, with Community Directive 71/127, 79/795, 80/780, 85/205, 86/562 or 88/321 or ECE Regulation 46.01; and
- (e) if it is any other vehicle with Community Directive 71/127, 79/795, 85/205, 86/562 or 88/321 or ECE Regulation 46.01.

34 Windscreen wipers and washers

- (1) Subject to paragraphs (4) and (5), every vehicle fitted with a windscreen shall, unless the driver can obtain an adequate view to the front of the vehicle without looking through the windscreen, be fitted with one or more efficient automatic windscreen wipers capable of clearing the windscreen so that the driver has an adequate view of the road in front of both sides of the vehicle and to the front of the vehicle.
- (2) Save as provided in paragraphs (3), (4) and (5), every wheeled vehicle required by paragraph (1) to be fitted with a wiper or wipers shall also be fitted with a windscreen washer capable of cleaning, in conjunction with the windscreen wiper, the area of the windscreen swept by the wiper, of mud or similar deposit.
- (3) The requirement specified in paragraph (2) does not apply in respect of –
 - (a) an agricultural motor vehicle (other than a vehicle first used on or after 1st June 1986 which is driven at more than 20 mph);
 - (b) a track-laying vehicle;
 - (c) a vehicle having a maximum speed not exceeding 20 mph; or
 - (d) a bus being used to provide a service licensed under the 1935 Law.
- (4) Instead of complying with paragraphs (1) and (2), a vehicle may comply with Community Directive 78/318.
- (5) Instead of complying with paragraph (1), an agricultural motor vehicle may comply with Community Directive 79/1073.
- (6) Every wiper and washer fitted in accordance with this Article shall at all times while a vehicle is being used on a road be maintained in efficient working order and be properly adjusted.

*F – INSTRUMENTS AND EQUIPMENT***35 Speedometers**

- (1) Save as provided in paragraphs (2) and (3), every motor vehicle shall be fitted with a speedometer which, if the vehicle is first used on or after 1st April 1984, shall be capable of indicating speed in both miles per hour and kilometres per hour, either simultaneously or, by the operation of a switch, separately.
- (2) Paragraph (1) does not apply to –
 - (a) a vehicle having a maximum speed not exceeding 25 mph;
 - (b) a vehicle which it is at all times unlawful to drive at more than 25 mph;
 - (c) an agricultural motor vehicle which is not driven at more than 20 mph;
 - (d) a motor cycle first used before 1st April 1984 the engine of which has a cylinder capacity not exceeding 100 cc;
 - (e) an invalid carriage first used before 1st April 1984;
 - (f) a works truck first used before 1st April 1984;
 - (g) a vehicle first used before 1st October 1937; or
 - (h) a vehicle equipped with recording equipment marked with a marking designated as an approval mark by regulation 5 of the Approval Marks Regulations and shown in item 3 in Schedule 4 to those Regulations (whether or not the vehicle is required to be equipped with that equipment) and which, as regards the visual indications given by that equipment of the speed of the vehicle, complies with the requirements relating to the said indications and installations specified in the Community Recording Equipment Regulation.
- (3) Instead of complying with paragraph (1), a vehicle may comply with Community Directive 75/443 or with ECE Regulation 39.

36 Maintenance of speedometers

- (1) Every instrument for indicating speed fitted to a motor vehicle –
 - (a) in compliance with the requirements of Article 35(1) or(3); or
 - (b) to which Article 35(2)(h) relates and which is not, under the Community Recording Equipment Regulation, required to be equipped with the recording equipment mentioned in that paragraph,shall be kept free from any obstruction which might prevent its being easily read and shall at all material times be maintained in good working order.
- (2) In this Article “all material times” means all times when the motor vehicle is in use on a road except when –
 - (a) the vehicle is being used on a journey during which, as a result of a defect, the instrument ceased to be in good working order; or
 - (b) as a result of a defect, the instrument has ceased to be in good working order and steps have been taken to have the vehicle equipped with all reasonable

expedition, by means of repairs or replacement, with an instrument which is in good working order.

37 Audible warning instruments

- (1)
 - (a) Subject to sub-paragraph (b), every motor vehicle which has a maximum speed of more than 20 mph shall be fitted with a horn, not being a reversing alarm or a 2-tone horn.
 - (b) Sub-paragraph (a) shall not apply to an agricultural motor vehicle, unless it is being driven at more than 20 mph.
- (2) Subject to paragraph (6), the sound emitted by any horn, other than a reversing alarm or a 2-tone horn, fitted to a wheeled vehicle first used on or after 1st August 1973 shall be continuous and uniform and not strident.
- (3) A reversing alarm fitted to a wheeled vehicle shall not be strident.
- (4) Subject to paragraphs (5), (6) and (7), no motor vehicle shall be fitted with a bell, gong, siren or 2-tone horn.
- (5) The provisions of paragraph (4) shall not apply to motor vehicles –
 - (a) used for the purposes of the Fire and Rescue Service or the Jersey Coastguard service or for ambulance or police purposes;
 - (b) authorized by the Minister and used for the purposes of the disposal of bombs or explosives;
 - (c) owned by the Royal National Lifeboat Institution and used for the purposes of launching lifeboats.⁸
- (6) The provisions of paragraphs (2) and (4) shall not apply so as to make it unlawful for a motor vehicle to be fitted with an instrument or apparatus (not being a 2-tone horn) designed to emit a sound for the purpose of informing members of the public that goods are on the vehicle for sale.
- (7) Subject to paragraph (8), the provisions of paragraph (4) shall not apply so as to make it unlawful for a vehicle to be fitted with a bell, gong or siren –
 - (a) if the purpose thereof is to prevent theft or attempted theft of the vehicle or its contents; or
 - (b) in the case of a bus, if the purpose thereof is to summon help for the driver, the conductor or an inspector.
- (8) Every bell, gong or siren fitted to a vehicle by virtue of paragraph (7)(a), and every device fitted to a motor vehicle first used on or after 1st October 1982 so as to cause a horn to sound for the purpose mentioned in paragraph (7)(a), shall be fitted with a device designed to stop the bell, gong or siren emitting noise for a continuous period of more than 5 minutes; and every such device shall at all times be maintained in good working order.
- (9) Instead of complying with paragraphs (1), (2) and (4) to (8), a vehicle may comply with Community Directive 70/388 or ECE Regulation 28 or, if the vehicle is an agricultural motor vehicle, with Community Directive 74/151.
- (10) In this Article and in Article 105 –

- (a) “horn” means an instrument, not being a bell, gong or siren, capable of giving audible and sufficient warning of the approach or position of the vehicle to which it is fitted;
- (b) references to a bell, gong or siren include references to any instrument or apparatus capable of emitting a sound similar to that emitted by a bell, gong or siren;
- (c) “reversing alarm” means a device fitted to a motor vehicle and designed to warn persons that the vehicle is reversing or is about to reverse; and
- (d) “2-tone horn” means an instrument which, when operated automatically, produces a sound which alternates at regular intervals between 2 fixed notes.

38 Motor cycle sidestands

- (1) No motor cycle first used on or after 1st April 1986 shall be fitted with any sidestand which is capable of –
 - (a) disturbing the stability or direction of the motor cycle when it is in motion under its own power; or
 - (b) closing automatically if the angle of the inclination of the motor cycle is inadvertently altered when it is stationary.
- (2) In this Article, “sidestand” means a device fitted to a motor cycle which, when fully extended or pivoted to its open position, supports the vehicle from one side only and so that both the wheels of the motor cycle are on the ground.

G – FUEL

39 Fuel tanks

- (1) This Article applies to every fuel tank which is fitted to a wheeled vehicle for the purpose of supplying fuel to the propulsion unit or to an ancillary engine or to any other equipment forming part of the vehicle.
- (2) Subject to paragraphs (3), (4) and (5), every fuel tank to which this Article applies –
 - (a) shall be constructed and maintained so that the leakage of any liquid from the tank is adequately prevented;
 - (b) shall be constructed and maintained so that the leakage of vapour from the tank is adequately prevented; and
 - (c) if it contains petroleum spirit (as defined in section 23 of the Petroleum (Consolidation) Act 1928 of the United Kingdom) and is fitted to a vehicle first used on or after 1st July 1973, shall be –
 - (i) made only of metal, and
 - (ii) fixed in such a position and so maintained as to be reasonably secure from damage.

- (3) Notwithstanding the requirement of paragraph (2)(b), the fuel tank may be fitted with a device which, by the intake of air or the emission of vapour, relieves changes of pressure in the tank.
- (4) Paragraph (2)(c)(i) shall not have effect in relation to a motor cycle (with or without a side-car) first used on or after 1st February 1993.
- (5) Instead of complying with the requirements of paragraphs (2) and (3) as to construction, a vehicle may comply with the requirements of Community Directive 70/221 (insofar as they relate to fuel tanks) or ECE Regulation 34 or 34.01 or, if the vehicle is an agricultural motor vehicle, of Community Directive 74/151.

40 Vehicles designed and constructed to run on unleaded petrol

- (1) Every vehicle to which this Article applies shall be designed and constructed for running on unleaded petrol.
- (2) No person shall use or cause or permit to be used a vehicle to which this Article applies on a road if it –
 - (a) has been deliberately altered or adjusted for running on leaded petrol; and
 - (b) as a direct result of such alteration or adjustment it is incapable of running on unleaded petrol.
- (3) Subject to paragraph (4), this Article applies to every motor vehicle which is –
 - (a) propelled by a spark ignition engine which is capable of running on petrol; and
 - (b) first used on or after 1st April 1991.
- (4) Part 1 of Schedule 3 shall have effect for the purpose of excluding certain vehicles first used before specified dates from the application of this Article.
- (5) In this Article “petrol”, “leaded petrol” and “unleaded petrol” have the same meaning as in Community Directive 85/210.
- (6) A vehicle shall be regarded for the purposes of this Article as incapable of running on unleaded petrol at any particular time if and only if in its state of adjustment at that time prolonged continuous running on such petrol would damage the engine.

41 Dimension of fuel tanks for purposes of filling

- (1) Subject to paragraph (2), every fuel tank fitted to a vehicle to which Article 40 applies shall be so constructed and fitted that it cannot readily be filled from a petrol pump delivery nozzle which has an external diameter of 23.6 mm or greater without the aid of a device (such as a funnel) not fitted to the vehicle.
- (2) Paragraph (1) does not apply to a vehicle in respect of which both of the following conditions are satisfied, that is to say –
 - (a) that at the time of its first use the vehicle is so designed and constructed that prolonged continuous running on leaded petrol would not cause any device designed to control the emission of carbon monoxide, hydrocarbons or nitrogen oxides to malfunction; and
 - (b) that it is conspicuously and legibly marked in a position immediately visible to a person filling the fuel tank with –

- (i) the word “UNLEADED”, or
 - (ii) the symbol shown in Part 2 of Schedule 3.
- (3) In this Article “fuel tank”, in relation to a vehicle, means a fuel tank used in connection with propulsion of the vehicle.

42 Gas propulsion systems and gas-fired appliances

- (1) A vehicle which is –
- (a) a motor vehicle which first used gas as a fuel for its propulsion before 19th November 1982; or
 - (b) a trailer manufactured before 19th November 1982 to which there is fitted a gas container,
- shall be so constructed that it complies with Schedule 4 or with Schedule 5.
- (2) A vehicle which is –
- (a) a motor vehicle which first used gas as a fuel for its propulsion on or after 19th November 1982; or
 - (b) a motor vehicle first used on or after 1st May 1984 or a trailer manufactured on or after 19th November 1982 which is in either case equipped with a gas container or a gas-fired appliance,
- shall comply with Schedule 5.
- (3) In this Article, “gas container” has the meaning given in Schedule 4 where compliance with that Schedule is concerned and otherwise has the meaning given in Schedule 5.

H – MINIBUSES

43 Minibuses

The requirements specified in Schedule 6 shall apply to every minibus first used on or after 1st April 1988 except a vehicle –

- (a) manufactured by Land Rover U.K. Limited and known as the Land Rover; or
- (b) constructed or adapted for the secure transport of prisoners.

44 Fire extinguishing apparatus

- (1) No person shall use, or cause or permit to be used, on a road a minibus first used on or after 1st April 1988 unless it carries suitable and efficient apparatus for extinguishing fire which is of a type specified in Part 1 of Schedule 7.
- (2) The apparatus referred to in paragraph (1) shall be –
- (a) readily available for use;
 - (b) clearly marked with the appropriate British Standards Institution specification number; and

- (c) maintained in good and efficient working order.
- (3) This Article does not apply to a vehicle manufactured by Land Rover U.K. Limited and known as the Land Rover.

45 First aid equipment

- (1) No person shall use, or cause or permit to be used, on a road a minibus first used on or after 1st April 1988 unless it carries a receptacle which contains the items specified in Part 2 of Schedule 7.
- (2) The receptacle referred to in paragraph (1) shall be –
 - (a) maintained in a good condition;
 - (b) suitable for the purpose of keeping the items referred to in the said paragraph in good condition;
 - (c) readily available for use; and
 - (d) prominently marked as a first aid receptacle.
- (3) The item referred to in paragraph (1) shall be maintained in good condition and shall be of a good and reliable quality and of a suitable design.
- (4) This Article does not apply to a vehicle manufactured by Land Rover U.K. Limited and known as the Land Rover.

46 Carriage of dangerous substances

- (1) Save as provided in paragraph (2), no person shall use or cause or permit to be used on a road a minibus by which any highly flammable or otherwise dangerous substance is carried unless that substance is carried in containers so designed and constructed, and unless the substance is so packed, that, notwithstanding an accident to the vehicle, it is unlikely that damage to the vehicle or injury to passengers in the vehicle will be caused by the substance.⁹
- (2) Paragraph (1) shall not apply in relation to the electrolyte of a battery installed in an electric wheelchair provided that the wheelchair is securely fixed to the vehicle.
- (3) This Article does not apply to a vehicle manufactured by Land Rover U.K. Limited and known as the Land Rover.

I – POWER TO WEIGHT RATIO

47 Power to weight ratio

- (1) Save as provided in paragraph (2), every wheeled vehicle which is propelled by a compression ignition engine and which is required to be equipped with a plate by Article 73(1) shall be so constructed that the power of its engine, calculated in accordance with paragraph 1 of Part 3 of Schedule 10, is at least 4.4 kW for every 1,000 kg of the relevant weight.
- (2) Paragraph (1) does not apply to –
 - (a) a heavy motor car or motor car first used before 1st April 1973;

- (b) a vehicle manufactured before 1st April 1973 and powered by a Perkins 6.354 engine; or
 - (c) a bus.
- (3) Every vehicle to which this Article applies shall –
- (a) if it is equipped with machinery or apparatus forming part of the vehicle or mounted on it and used for purposes not connected with the driving of the vehicle;
 - (b) if that machinery or apparatus is designed for use or is likely to be used, when the vehicle is in motion on a road at a speed exceeding 5 mph; and
 - (c) if the power absorbed by that use is provided by the engine propelling the vehicle,
- be so constructed that, when the machinery or apparatus is being used, the power of the engine remaining available to drive the vehicle is at least 4.4 kW for every 1,000 kg of the relevant weight.
- (4) In this Article “relevant weight” means –
- (a) if the vehicle is equipped with a plate in accordance with Article 73(2)(a), the maximum train weight shown at item 8 on that plate or, if no such weight is shown, the maximum gross weight in Jersey shown at item 10 on that plate; or
 - (b) if the vehicle is equipped with a plate in accordance with Article 73(2)(b) and –
 - (i) is constructed to draw a trailer, the higher of the weights referred to in column 3 in item 2.1.5 in the Table in Article 73, or
 - (ii) is not constructed to draw a trailer, the higher of the weights for motor vehicles referred to in columns 3 and 4 in item 2.1.4 in the Table in Article 73.

J – PROTECTIVE SYSTEMS

48 Seat belt anchorage points

- (1) Save as provided by paragraph (2), this Article applies to –
- (a) every wheeled motor car first used on or after 1st January 1967;
 - (b) every motor tricycle the unladen weight of which exceeds 255 kg and which was first used on or after 1st September 1970; and
 - (c) every heavy motor car first used on or after 1st October 1988.
- (2) This Article does not apply to –
- (a) a goods vehicle (other than a dual-purpose vehicle) which was first used –
 - (i) before 1st April 1967, or
 - (ii) on or after 1st April 1980 and before 1st October 1988 and has a maximum gross weight exceeding 3,500 kg, or

- (iii) before 1st April 1980 or, if the vehicle is of a model manufactured before 1st October 1979, was first used before 1st April 1982 and, in either case, has an unladen weight exceeding 1525 kg;
 - (b) a bus being –
 - (i) a minibus –
 - (A) if first used before 1st October 1988, constructed or adapted to carry more than 12 passengers, or
 - (B) if first used on or after 1st October 1988, having a maximum gross weight exceeding 3,500 kg, or
 - (ii) a large bus (other than a coach first used on or after 1st October 1988);
 - (c) an agricultural motor vehicle;
 - (d) a motor tractor;
 - (e) a works truck;
 - (f) an electrically-propelled goods vehicle first used before 1st October 1988;
 - (g) a pedestrian-controlled vehicle;
 - (h) a vehicle which has been used on roads outside Jersey and has been imported into Jersey whilst it is being driven from a port where it has arrived in Jersey to a place of residence of the owner or driver of the vehicle, or from any such place to a place where, by previous arrangement, it will be provided with such anchorage points as are required by this Article and such seat belts as are required by Article 49;
 - (i) a vehicle having a maximum speed not exceeding 16 mph;
 - (j) a locomotive.
- (3) A vehicle which was first used before 1st April 1982 shall be equipped with anchorage points which are designed to hold securely in position on the vehicle seat belts for the driver's seat and specified passenger's seat (if any).
- (4) Save as provided in paragraph (5) or (6), a vehicle which is first used on or after 1st April 1982 shall be equipped with anchorage points which –
- (a) are designed to hold securely in position on the vehicle seat belts for –
 - (i) in the case of a minibus, motor ambulance or a motor caravan –
 - (A) if first used before 1st October 1988, the driver's seat and the specified passenger's seat (if any), or
 - (B) if first used on or after 1st October 1988, the driver's seat and any forward-facing front seat, and
 - (ii) in the case of any other passenger or dual-purpose vehicle, every forward-facing seat constructed or adapted to accommodate one adult,
 - (iii) in every other case, every forward-facing front seat and every non-protected seat; and
 - (b) comply with the technical and installation requirements of Community Directive 76/115 or 81/575 or 82/318 or 90/629 or ECE Regulation 14, 14.01, 14.02 or 14.03 whether or not those instruments apply to the vehicle,

so however, that the requirements in those instruments which relate to testing shall not apply.

- (5) The requirements specified in paragraph (4) shall not apply to –
- (a) a goods vehicle first used on or after 1st October 1988 but before 1st October 2001 and having a maximum gross weight exceeding 3500 kg, but any such vehicle must be equipped with 2 or 3 anchorage points designed to hold securely in position seat belts for the driver’s seat and each forward-facing front seat;
 - (aa) a goods vehicle first used on or after 1st October 2001 and having a maximum gross weight exceeding 3500 kg, but any such vehicle must be equipped with anchorage points which –
 - (i) are designed to hold securely in position on the vehicle seat belts for each forward-facing front seat, and
 - (ii) comply with the technical and installation requirements of Community Directive 96/38 or ECE Regulation 14.04 or 14.05; or
 - (b) a coach equipped with anchorage points which are designed to hold securely in position on the vehicle seat belts for all exposed forward-facing seats and which –
 - (i) comply with the requirements in paragraph (4)(b), or
 - (ii) in any case where the anchorage points form part of a seat, do not when a forward horizontal force is applied to them become detached from the seat of which they form part before that seat becomes detached from the vehicle.¹⁰
- (6) Instead of complying with the requirements in paragraph (4), a vehicle may comply with –
- (a) Community Directive 76/115 or 81/575 or 82/318 or 90/629;
 - (b) ECE Regulation 14, 14.01, 14.02 or 14.03.
- (7) Save as provided in paragraph (8), a vehicle of a type mentioned in paragraphs (4), (5) and (6) which is fitted with anchorage points other than those required by those paragraphs shall comply with the requirements in paragraph (4)(b), or in the case of a coach the requirements in paragraph (5)(b)(ii), in respect of any additional anchorage points as well as in respect of the anchorage points required by paragraph (4), (5) or (6) to be provided.
- (8) The requirements in paragraph (7) shall not apply in respect of any additional anchorage points first fitted before 1st April 1986, in the case of a vehicle of a type mentioned in paragraph (4)(a)(i)(A), or before 1st October 1988 in the case of a vehicle of any other type.
- (9) In this Article –
- (a) the expressions “exposed forward-facing seat”, “forward-facing seat”, “forward-facing front seat”, “lap belt”, “seat belt” and “specified passenger’s seat” have the same meaning as in Article 49(11);
 - (b) a seat is a “non-protected seat” if it is not a front seat and the screen zones within the protected area have a combined surface area of less than 800 cm²; and

- (c) “screen zone” and “protected area”, in relation to a seat, shall be construed in accordance with paragraph 4.3.3 of Annex I to Community Directive 81/575.

49 Seat belts

- (1) This Article applies to every vehicle to which Article 48 applies.
- (2) Save as provided in paragraph (4), a vehicle to which –
- (a) this Article applies which was first used before 1st April 1981 shall be provided with –
- (i) a body-restraining belt, designed for use by an adult, for the driver’s seat, and
- (ii) a body-restraining belt for the specified passenger’s seat (if any);
- (b) this Article applies which is first used on or after 1st April 1981 shall be provided with 3-point belts for the driver’s seat and for the specified passenger’s seat (if any);
- (c) Article 48(4)(a)(ii) or (iii) apply which is first used on or after 1st April 1987 shall be fitted with seat belts additional to those required by sub-paragraph (b) as follows –
- (i) for any forward-facing front seat alongside the driver’s seat, not being a specified passenger’s seat, a seat belt which is a 3-point belt, or a lap belt installed in accordance with paragraph 3.1.2.1 of Annex 1 to Community Directive 77/541 or a disabled person’s belt,
- (ii) in the case of a passenger or dual-purpose vehicle having not more than 2 forward-facing seats behind the driver’s seat with either –
- (A) an inertia reel belt for at least one of those seats; or
- (B) a 3-point belt, a lap belt, a disabled person’s belt or a child restraint for each of those seats,
- (iii) in the case of a passenger or dual-purpose vehicle having more than 2 forward-facing seats behind the driver’s seat, with either –
- (A) an inertia reel belt for one of those seats being an outboard seat and a 3-point belt, a lap belt, a disabled person’s belt or a child restraint for at least one other of those seats,
- (B) a 3-point belt for one of those seats and either a child restraint or a disabled person’s belt for at least one other of those seats, or
- (C) a 3-point belt, a lap belt, a disabled person’s belt or a child restraint for each of those seats;
- (d) Article 48(4)(a)(i)(B) applies shall be fitted with seat belts as follows –
- (i) for the driver’s seat and the specified passenger’s seat (if any) a 3-point belt, and
- (ii) for any forward-facing front seat which is not a specified passenger’s seat, a 3-point belt or a lap belt installed in accordance with the provisions of sub-paragraph (c)(i);

- (e) Article 48(5)(b) applies shall be equipped with seat belts which shall be 3-point belts, lap belts or disabled person's belts;
- (f) Article 48(5)(aa) applies shall be fitted with seat belts as follows –
 - (i) for the driver's seat with a 3-point belt or a lap belt, and
 - (ii) for any forward-facing front seat –
 - (A) a 3-point belt,
 - (B) a lap belt installed in accordance with paragraph 3.1.2 of Annex 1 to Community Directive 77/541 (having regard to Articles 4 and 19 of Council Regulation (EC) No 661/2009 of 13 July 2009 concerning type-approval requirements for the general safety of motor vehicles, their trailers and systems, components and separate technical units intended therefor (OJ L 200 p.1), or
 - (C) a disabled person's belt.

Where a lap belt is fitted to a forward-facing front seat of a minibus, a motor ambulance or a motor caravan, or to an exposed forward-facing seat (other than the driver's seat or any crew seat) of a coach either –

- (i) there shall be provided padding to a depth of not less than 50 mm, on that part of the surface or edge of any bar, or the top or edge of any screen or partition, which would be likely to be struck by the head of a passenger wearing the lap belt in the event of an accident, or
- (ii) the technical and installation requirements of Annex 4 to ECE Regulation 21 shall be met, in respect of any such bar, screen or partition,

but nothing in sub-paragraph (i) shall require padding to be provided on any surface more than 1 m from the centre of the line of intersection of the seat cushion and the back rest or more than 150 mm on either side of the longitudinal vertical plane which passes through the centre of that line, nor shall it require padding to be provided on any instrument panel of a minibus.¹¹

- (3) Every seat belt for an adult, other than a disabled person's belt, provided for a vehicle in accordance with paragraph (2)(b), (c), (d) or (e) shall, except as provided in paragraph (6), comply with the installation requirements specified in paragraph 3.2.2 to 3.3.4 of Annex 1 to Community Directive 77/541 or 82/319 or 90/628 whether or not those Directives apply to the vehicle.
- (4) The requirements specified in paragraph (2) do not apply –
 - (a) to a vehicle while it is being used under a trade licence within the meaning of Article 8 of the 1993 Law;
 - (b) to a vehicle, not being a vehicle to which the Type Approval (Great Britain) Regulations apply, while it is being driven from premises of the manufacturer by whom it was made, or of a distributor of vehicles or dealer in vehicles –
 - (i) to premises of a distributor of or dealer in vehicles or of the purchaser of the vehicle, or
 - (ii) to premises of a person obtaining possession of the vehicle under a hiring agreement or a hire-purchase agreement;

- (c) in relation to any seat for which there is provided –
 - (i) a seat belt which bears a mark including the specification number of the British Standard for Passive Belt Systems, namely BS AU 183: 1983 and including the registered certification trade mark of the British Standards Institution,
 - (ii) a seat belt designed for use by an adult which is a harness belt comprising a lap belt and shoulder straps which bears a British Standard mark or a mark including the specification number for the British Standard for Seat Belt Assemblies for Motor Vehicles, namely BS AU 3254: 1960 or BS AU 3254: Part 1: 1988 and including the registered certification trade mark of the British Standards Institution, or the marking designated as an Approval Mark by Regulation 4 of the Approval Marks Regulations and shown at item 16 or 16A in Schedule 2 to those Regulations,
 - (iii) a seat belt which satisfies the requirements of a standard corresponding to the British Standard referred to in clause (i), or
 - (iv) a seat belt designed for use by an adult which is a harness belt comprising a lap belt and shoulder straps and which satisfies the requirements of a standard corresponding to any of the British Standards referred to in clause (ii);
 - (d) in relation to the driver's seat or the specified passenger's seat (if any) of a vehicle which has been specially designed and constructed, or specially adapted, for the use of a person suffering from some physical defect or disability, in a case where a disabled person's belt for an adult person is provided for use for that seat;
 - (e) to a vehicle to which Article 48(5)(a) applies.
- (5) Every seat belt provided in pursuance of paragraph (2) shall be properly secured to the anchorage points provided for it in accordance with Article 48, or, in the case of a child restraint, to anchorages specially provided for it or, in the case of a disabled person's belt, secured to the vehicle or to the seat which is being occupied by the person wearing the belt.
- (6) Paragraph (3), in so far as it relates to the second paragraph of paragraph 3.3.2 of the Annex there mentioned (which concerns the locking or releasing of a seat belt by a single movement) does not apply in respect of a seat belt fitted for –
- (a) a seat which is treated as a specified passenger's seat by virtue of the provisions of sub-paragraph (b) in the definition of "specified passenger's seat" in paragraph (11); or
 - (b) any forward facing seat for a passenger alongside the driver's seat of a goods vehicle which has an unladen weight of more than 915 kg and has more than one such seat, any such seats for passengers being joined together in a single structure; or
 - (c) any seat (other than the driver's seat) fitted to a coach.
- (7) Every seat belt, other than a disabled person's seat belt or a seat belt of a kind mentioned in paragraph (4)(c)(i) and (ii), provided for any person in a vehicle to which this Article applies shall be legibly and permanently marked –
- (a) with a British standard mark or a designated approval mark; or

- (b) with an EC Component Type-Approval Mark complying with Annex III to Community Directive 2000/3:

Provided this paragraph shall not operate so as to invalidate the exception permitted in paragraph (6).¹²

- (8) Paragraph (7) does not apply to –
- (a) a seat belt for an adult that satisfies the requirements of a standard corresponding to either of the British Standards referred to in sub-paragraph (a)(i) of the definition of “British Standard mark” in paragraph (11); or
 - (b) a child restraint that satisfies the requirements of a standard corresponding to any of the British Standards referred to in sub-paragraph (a)(ii) of that definition.
- (9) For the purpose of this Article a reference to a standard corresponding to a specified British Standard is a reference to –
- (a) a standard or code of practice of a national standards body or equivalent body of any EEA State;
 - (b) any international standard recognized for use as a standard by any EEA State; or
 - (c) a technical specification recognized for use as a standard by a public authority of any EEA State,

where the standard, code of practice, international standard or technical specification provides in relation to seat belts, a level of safety equivalent to that provided by the British Standard and contains a requirement as respects the marking of seat belts equivalent to that provided by the British Standard.

- (10) For the purposes of paragraph (9) –
- (a) “EEA State” means a State which is a contracting Party to the EEA Agreement but, until the EEA Agreement comes into force in relation to Liechtenstein, does not include the state of Liechtenstein; and
 - (b) “EEA Agreement” means the Agreement on the European Economic Area signed at Oporto on 2nd May 1992 as adjusted by the Protocol signed at Brussels on 17th March 1993.

- (11) In this Article –

“body-restraining belt” means a seat belt designed to provide restraint for both the upper and lower parts of the trunk of the wearer in the event of an accident to the vehicle;

“British Standard Mark” means a mark consisting of –

- (a) the specification number of one of the following British Standards for Seat Belt Assemblies for Motor Vehicles, namely –
 - (i) if it is a seat belt for an adult, BS 3254: 1960 and BS 3254: Part 1: 1988, or
 - (ii) if it is a child restraint, BS 3254: 1960, or BS 3254: 1960 as amended by Amendment No. 16 published on 31st July 1986 under the number AMD 5210, BS 3254: Part 2: 1988 or BS 3254: Part 2: 1991, BS

AU 185, BS AU 186 or 186a, BS AU 202, BS AU 202a or BS AU 202b; and, in either case;

(b) the registered certification trade mark of the British Standards Institution;

“child restraint” means a seat belt for the use of a young person which is designed either to be fitted directly to a suitable anchorage or to be used in conjunction with a seat belt for an adult and held in place by the restraining action of that belt:

Provided that for the purposes of paragraph (2)(c)(ii)(B) and (c)(iii), it means only such seat belts fitted directly to a suitable anchorage and excludes belts marked with the specification numbers BS AU 185 and BS AU 186 or 186a;

“crew seat” has the same meaning as in Regulation 3(1) of the Public Service Vehicles (Conditions of Fitness Equipment, Use and Certification) Regulations 1981 of the United Kingdom;

“designated approval mark” means –

- (a) if it is a seat belt other than a child restraint, the marking designated as an approval mark by regulation 4 of the Approval Marks Regulations and shown at items 16 and 16A of Schedule 2 to those Regulations or the marking designated as an approval mark by regulation 5 of those Regulations and shown at item 23, 23A and 23B in Schedule 4 to those Regulations; and
- (b) if it is a child restraint, any of the markings designated as approval marks by regulation 4 of those Regulations and shown at items 44, 44A, 44B and 44C in Schedule 2 to those Regulations;

“disabled person’s belt” means a seat belt which has been specially designed or adapted for use by an adult or young person suffering from some physical defect or disability and which is intended for use solely by such a person;

“exposed forward-facing seat” means –

- (a) a forward-facing front seat (including any crew seat) and the driver’s seat; and
- (b) any other forward-facing seat which is not immediately behind and on the same horizontal plane as a forward-facing high-backed seat;

“forward-facing seat” means a seat which is attached to a vehicle so that it faces towards the front of the vehicle in such a manner that a line passing through the centre of both the front and the back of the seat is at an angle of 30° or less to the longitudinal axis of the vehicle;

“forward-facing front seat” means –

- (a) any forward-facing seat alongside the driver’s seat; or
- (b) if the vehicle normally has no seat which is a forward-facing front seat under sub-paragraph (a) of this definition, each forward-facing seat for a passenger which is foremost in the vehicle;

“forward-facing high-backed seat” means a forward-facing seat which is also a high-backed seat;

“high-backed seat” means a seat the highest part of which is at least 1 metre above the deck of the vehicle;

“inertia reel belt” means a 3-point belt of either of the types required for a front outboard seating position by paragraph 3.1.1 of Annex 1 to Community Directive 77/541;

“lap belt” means a seat belt which passes across the front of the wearer’s pelvic region and which is designed for use by an adult;

“seat” includes any part designed for the accommodation of one adult of a continuous seat designed for the accommodation of more than one adult;

“seat belt” means a belt intended to be worn by a person in a vehicle and designed to prevent or lessen injury to its wearer in the event of an accident to the vehicle and includes, in the case of a child restraint, any special chair to which the belt is attached;

“specified passenger’s seat” means –

- (a) in the case of a vehicle which has one forward-facing front seat alongside the driver’s seat, that seat, and in the case of a vehicle which has more than one such seat, the one furthest from the driver’s seat; or
- (b) if the vehicle normally has no seat which is the specified passenger’s seat under sub-paragraph (a) of this definition the forward-facing front seat for a passenger which is the foremost in the vehicle and furthest from the driver’s seat, unless there is a fixed partition separating that seat from the space in front of it along-side the driver’s seat; and

“3-point belt” means a seat belt which –

- (a) restrains the upper and lower parts of the torso;
- (b) includes a lap belt;
- (c) is anchored at not less than 3 points; and
- (d) is designed for use by an adult.¹³

50 Maintenance of seat belts and anchorage points

- (1) This Article applies to every seat belt with which a motor vehicle is required to be provided in accordance with Article 49 and to the anchorages, fastenings, adjusting device and retracting mechanism (if any) of every such seat belt and also to every anchorage with which a goods vehicle is required to be provided in accordance with Article 48(5)(a) or (5)(aa).¹⁴
- (2) For the purposes of this Article the anchorages and anchorage points of a seat belt shall, in the case of a seat which incorporates integral seat belt anchorages, include the system by which the seat assembly itself is secured to the vehicle structure.
- (3) The anchorage points provided for seat belts shall be used only as anchorages for the seat belts for which they are intended to be used or capable of being used.
- (4) Save as provided in paragraph (5) –
 - (a) all load-bearing members of the vehicle structure or panelling within 30 cms of each anchorage point shall be maintained in a sound condition and free from serious corrosion, distortion or fracture;
 - (b) the adjusting device and (if fitted) the retracting mechanism of the seat belt shall be so maintained that the belt may be readily adjusted to the body of

- the wearer, either automatically or manually, according to the design of the device and (if fitted) the retracting mechanism;
- (c) the seat belt and its anchorages, fastenings and adjusting device shall be maintained free from any obvious defect which would be likely to affect adversely the performance by the seat belt of the function of restraining the body of the wearer in the event of an accident to the vehicle;
 - (d) the buckle or other fastening of the seat belt shall –
 - (i) be so maintained that the belt can be readily fastened or unfastened,
 - (ii) be kept free from any temporary or permanent obstruction, and
 - (iii) except in the case of a disabled person's seat belt, be readily accessible to a person sitting in the seat for which the seat belt is provided;
 - (e) the webbing or other material which forms the seat belt shall be maintained free from cuts or other visible faults (as, for example, extensive fraying) which would be likely to affect adversely the performance of the belt when under stress;
 - (f) the ends of every seat belt, other than a disabled person's seat belt, shall be securely fastened to the anchorage points provided for them; and
 - (g) the ends of every disabled person's seat belt shall, when the seat belt is being used for the purpose for which it was designed and constructed, be securely fastened either to some part of the structure of the vehicle or to the seat which is being occupied by the person wearing the belt so that the body of the person wearing the belt would be restrained in the event of an accident to the vehicle.
- (5) No requirement specified in paragraph (4) applies if the vehicle is being used –
- (a) on a journey after the start of which the requirement ceased to be complied with; or
 - (b) after the requirement ceased to be complied with and steps have been taken for such compliance to be restored with all reasonable expedition.
- (6) Expressions which are used in this Article and are defined in Article 49 have the same meaning in this Article as they have in Article 49.

51 Minibuses and coaches to be fitted with additional seat belts when used in certain circumstances

- (1) No person shall use or cause or permit to be used on a road a coach or minibus wholly or mainly for the purpose of carrying a group of 3 or more children in the following circumstances unless the appropriate number of forward-facing passenger seats fitted to the vehicle meet the requirements of this Article.
- (2) The circumstances are that –
- (a) the group of children are on an organized trip; and
 - (b) the journey is being made for the purposes of the trip.

- (3) In paragraph (1), the reference to the appropriate number is a reference to the number of children being carried in the vehicle (excluding disabled children in wheelchairs).
- (4) Without prejudice to the generality of paragraph (2)(a), a group of children shall, for the purposes of this Article, be regarded as being on an organized trip if they are being carried to or from their school or from one part of their school premises to another.
- (5) Without prejudice to the meaning of paragraph (2)(b), paragraph (1) shall not apply to a vehicle if it is being used wholly or mainly for the purpose of providing a transport service for the general public.
- (6) For a forward-facing passenger seat to meet the requirements of this Article a seat belt must be provided for it, and –
- (a) if Article 49(3) does not (in whole or part) apply to the seat belt and the seat belt was first fitted to the vehicle after 10th February 1999, the seat belt must comply with that paragraph to the extent (if any) that it would have to so comply were –
 - (i) that Article to apply to all motor vehicles, and
 - (ii) there substituted for the words “provided” to “or (e)”, in that paragraph, the words “provided for any person in a vehicle to which this Article applies”;
 - (b) if Article 49(5) does not apply to the seat belt and the seat belt is a seat belt for an adult (not being a disabled person’s belt) that was first fitted to the vehicle after 10th February 1999, the seat belt must comply with the requirements specified in paragraph (7);
 - (c) if Article 49(5) does not apply to the seat belt and the seat belt is a child restraint that was first fitted to the vehicle after 10th February 1999, the seat belt must be properly secured to anchorages provided for it;
 - (d) if Article 49(5) does not apply to the seat belt and the seat belt is a disabled person’s belt that was first fitted to the vehicle after 10th February 1999, the seat belt must be properly secured to the vehicle or to the seat;
 - (e) if Article 49 does not apply to the vehicle and the seat belt was first fitted to the vehicle after 10th February 1999, the seat belt must comply with paragraph (7) of that Article to the extent (if any) that it would have to so comply were that Article to apply to all motor vehicles; and
 - (f) if Article 50 does not apply to the seat belt and the seat belt was first fitted to the vehicle after 10th February 1999, the requirements of paragraph (4) of that Article must be met in relation to the anchorages, fastenings, adjusting device and retracting mechanism (if any) of the seat belt to the extent (if any) that those requirements would have to be met were that paragraph to apply to all anchorages, fastenings, adjusting devices and retracting mechanisms of seat belts fitted to motor vehicles,
- and Article 50(2) shall apply for the purposes of sub-paragraph (f) as it applies for the purposes of that Article.
- (7) The requirements referred to in paragraph (6)(b) are that the seat belt must be properly secured to the anchorage points provided for it and, in a case where any of

those anchorage points is first fitted to the vehicle after 10th February 1999 the anchorage points to which it is secured must comply –

- (a) if the vehicle is a coach, with the requirements specified in Article 48(4)(b) or paragraph (5)(b)(ii) of that Article; or
 - (b) in any other case, with the requirements specified in paragraph (4)(b) of that Article.
- (8) Until 10th February 2000, this Article shall not apply to a coach first used before 1st October 1988.
- (9) In this Article –
- “child restraint”, “disabled person’s belt”, “forward-facing seat”, “seat” and “seat belt” have the meanings given in Article 49;
- “forward-facing passenger seat” means a forward-facing seat which is not the driver’s seat; and
- “school” has the same meaning as in the [Education \(Jersey\) Law 1999](#).
- (10) For the purpose of this Article, a child is a person who is aged 3 years or more but is under the age of 16 years.

52 Rear under-run protection

- (1) Save as provided in paragraph (2), this Article applies to a wheeled goods vehicle being either –
- (a) a motor vehicle with a maximum gross weight which exceeds 3,500 kg and which was first used on or after 1st January 1999; or
 - (b) a trailer manufactured on or after 1st January 1999 with an unladen weight which exceeds 1020 kg.
- (2) This Article does not apply to –
- (a) a motor vehicle which has a maximum speed not exceeding 15 mph;
 - (b) a motor car or a heavy motor car constructed or adapted to form part of an articulated vehicle;
 - (c) an agricultural trailer;
 - (d) engineering plant;
 - (e) a fire engine;
 - (f) an agricultural motor vehicle;
 - (g) a vehicle fitted at the rear with apparatus specially designed for spreading material on a road;
 - (h) a vehicle so constructed that it can be unloaded by part of the vehicle being tipped rearwards;
 - (i) a vehicle used for the purposes of a home force or of a visiting force;
 - (j) a vehicle to which no bodywork has been fitted and which is being driven or towed –

- (i) for the purpose of a quality or safety check by its manufacturer or a dealer in, or distributor of, such vehicles,
 - (ii) to a place where, by previous arrangement, bodywork is to be fitted or work preparatory to the fitting of bodywork is to be carried out, or
 - (iii) by previous arrangement to premises of a dealer in, or distributor of, such vehicles;
- (k) a vehicle which is being driven or towed to a place where by previous arrangement a device is to be fitted so that it complies with this Article;
 - (l) a vehicle specially designed and constructed, and not merely adapted, to carry other vehicles loaded onto it from the rear;
 - (m) a trailer specially designed and constructed, and not merely adapted, to carry round timber, beams or girders, being items of exceptional length;
 - (n) a vehicle with a tail lift so constructed that the lift platform forms part of the floor of the vehicle and this part has a length of at least 1 m measured parallel to the longitudinal axis of the vehicle;
 - (o) a trailer having a base or centre outside Jersey from which it normally starts its journeys, provided that a period of not more than 12 months has elapsed since the vehicle was last brought into Jersey;
 - (p) a vehicle specially designed, and not merely adapted, for the carriage and mixing of liquid concrete;
 - (q) a vehicle designed and used solely for the delivery of coal by means of a special conveyor which is carried on the vehicle and when in use is fitted to the rear of the vehicle so as to render its being equipped with a rear under-run protective device impracticable; or
 - (r) an agricultural trailed appliance.¹⁵
- (3) Subject to paragraphs (4), (5) and (6), every vehicle to which this Article applies shall be equipped with a rear under-run protection device.
- (4) A vehicle to which this Article applies and which is fitted with a tail lift, bodywork or other part which renders its being equipped with a rear under-run protective device impracticable shall instead be equipped with one or more devices which do not protrude beyond the overall width of the vehicle (excluding any part of the device or the devices) and which comply with the following requirements –
- (a) where more than one device is fitted, not more than 50 cm shall lie between one device and the device next to it;
 - (b) not more than 30 cm shall lie between the outermost end of a device nearest to the outermost part of the vehicle to which it is fitted and a longitudinal plane passing through the outer end of the rear axle of the vehicle on the same side of the vehicle or, in a case where the vehicle is fitted with more than one rear axle, through the outer end of the widest rear axle on the same side of the vehicle and paragraph II.5.4.2 in the Annex to Community Directive 79/490 shall not have effect in a case where this requirement is met; and
 - (c) the device or, where more than one device is fitted, all the devices together, shall have the characteristics specified in paragraphs II.5.4.1 to II.5.4.5.5.2 in the Annex to the said Directive save –

- (i) as provided in sub-paragraphs (a) and (b),
 - (ii) that for the reference in paragraph II.5.4.5.1 in that Annex to 30 cm there is substituted a reference to 35 cm, and
 - (iii) that the distance of 40 cm specified in paragraph II.5.4.5 in that Annex may be measured exclusive of the said tail-lift, bodywork or other part.
- (5) The provisions of paragraph (3) shall have effect so that in the case of –
- (a) a vehicle which is fitted with a demountable body, the characteristics specified in paragraph II.5.4.2 in the Annex to the said Directive have effect as if the reference to 10 cm were a reference to 30 cm and as if in paragraph II.5.4.5.1 the reference to 30 cm were a reference to 35 cm; and
 - (b) a trailer with a single axle or 2 close-coupled axles, the height of 55 cm referred to in paragraph II.5.4.5.1 in that Annex is measured when the coupling of the trailer to the vehicle by which it is drawn is at the height recommended by the manufacturer of the trailer.
- (6) Instead of complying with paragraphs (3) to (5) a vehicle may comply with Community Directive 79/490.
- (7) In this Article –
- “rear under-run protective device” means a device within the description given in paragraph II.5.4 in the Annex to Community Directive 79/490.

53 Maintenance of rear under-run protective device

Every device fitted to a vehicle in compliance with the requirements of Article 52 shall at all times when the vehicle is on a road be maintained free from any obvious defect which would be likely to affect adversely the performance of the device in the function of giving resistance in the event of an impact from the rear.

54 Sideguards

- (1) Save as provided in paragraph (2), this Article applies to a wheeled goods vehicle being –
- (a) a motor vehicle first used on or after 1st January 1999 with a maximum gross weight which exceeds 3,500 kg;
 - (b) a trailer manufactured on or after 1st January 1999 with an unladen weight which exceeds 1020 kg; or
 - (c) a semi-trailer manufactured before 1st January 1999 which has a relevant plate showing a gross weight exceeding 26,000 kg.
- (2) This Article does not apply to –
- (a) a motor vehicle which has a maximum speed not exceeding 15 mph;
 - (b) an agricultural trailer;
 - (c) engineering plant;
 - (d) a fire engine;

- (e) an agricultural motor vehicle;
 - (f) a vehicle so constructed that it can be unloaded by part of the vehicle being tipped sideways or rearwards;
 - (g) a vehicle used for the purposes of a home force or of a visiting force;
 - (h) a vehicle to which no bodywork has been fitted and which is being driven or towed –
 - (i) for the purpose of a quality or safety check by its manufacturer or a dealer in, or distributor of, such vehicles,
 - (ii) to a place where, by previous arrangement, bodywork is to be fitted or work preparatory to the fitting of bodywork is to be carried out, or
 - (iii) by previous arrangement to premises of a dealer in, or distributor of, such vehicles;
 - (i) a vehicle which is being driven or towed to a place where by previous arrangement a sideguard is to be fitted so that it complies with this Order;
 - (j) a refuse vehicle;
 - (k) a trailer specially designed and constructed, and not merely adapted, to carry round timber, beams or girders, being items of exceptional length;
 - (l) a motor car or a heavy motor car constructed or adapted to form part of an articulated vehicle;
 - (m) a vehicle specially designed and constructed, and not merely adapted, to carry other vehicles loaded onto it from the front or the rear;
 - (n) a trailer with a load platform –
 - (i) no part of any edge of which is more than 60 mm inboard from the tangential plane, and
 - (ii) the upper surface of which is not more than 750 mm from the ground throughout that part of its length under which a sideguard would have to be fitted in accordance with paragraph (6)(d) to (g) if this exemption did not apply to it;
 - (o) a trailer having a base or centre outside Jersey from which it normally starts its journeys, provided that a period of not more than 12 months has elapsed since the vehicle was last brought into Jersey; or
 - (p) an agricultural trailed appliance.¹⁶
- (3) This Article also applies to a wheeled goods vehicle, whether of a description falling within paragraph (2) or not, which is a semi-trailer some or all of the wheels of which are driven by the drawing vehicle.
- (4) Every vehicle to which this Article applies shall be securely fitted with a sideguard to give protection on any side of the vehicle where –
- (a) if it is a semi-trailer, the distance between the transverse planes passing through the centre of its foremost axle and through the centre of its king-pin or, in the case of a vehicle having more than one king-pin, the rearmost one, exceeds 4.5 m; or
 - (b) if it is any other vehicle, the distance between the centres of any 2 consecutive axles exceeds 3 m.

- (5) Save as provided in paragraphs (7) and (8), a sideguard with which a vehicle is by this Article required to be fitted shall comply with all the specifications listed in paragraph (6).
- (6) Those specifications are –
- (a) the outermost surface of every sideguard shall be smooth, essentially rigid and either flat or horizontally corrugated, save that –
 - (i) any part of the surface may overlap another provided that the overlapping edges face rearwards or downwards,
 - (ii) a gap not exceeding 25 mm measured longitudinally may exist between any 2 adjacent parts of the surface provided that the foremost edge of the rearward part does not protrude outboard of the rearmost edge of the forward part, and
 - (iii) domed heads of bolts or rivets may protrude beyond the surface to a distance not exceeding 10 mm;
 - (b) no part of the lowest edge of a sideguard shall be more than 550 mm above the ground when the vehicle to which it is fitted is on level ground and, in the case of a semi-trailer, when its load platform is horizontal;
 - (c) in a case specified in an item in column 2 of the Table the highest edge of a sideguard shall be as specified in that item in column 3;
 - (d) the distance between the rearmost edge of a sideguard and the transverse plane passing through the foremost part of the tyre fitted to the wheel of the vehicle nearest to it shall not exceed 300 mm;
 - (e) the distance between the foremost edge of a sideguard fitted to a semi-trailer and a transverse plane passing through the centre of the vehicle's king-pin or, if the vehicle has more than one king-pin, the rearmost one, shall not exceed 3 m;
 - (f) the foremost edge of a sideguard fitted to a semi-trailer with landing legs shall, as well as complying with sub-paragraph (e), not be more than 250 mm to the rear of a transverse plane passing through the centre of the leg nearest to that edge;
 - (g) the distance between the foremost edge of a sideguard fitted to a vehicle other than a semi-trailer and a transverse plane passing through the rearmost part of the tyre fitted to the wheel of the vehicle nearest to it shall not exceed 300 mm if the vehicle is a motor vehicle and 500 mm if the vehicle is a trailer;
 - (h) the external edges of a sideguard shall be rounded at a radius of at least 2.5 mm;
 - (i) no sideguard shall be more than 30 mm inboard from the tangential plane;
 - (j) no sideguard shall project beyond the longitudinal plane from which, in the absence of a sideguard, the vehicle overall width would fall to be measured;
 - (k) every sideguard shall cover an area extending to at least 100 mm upwards from its lowest edge, 100 mm downwards from its highest edge, and 100 mm rearwards and inwards from its foremost edge, and no sideguard shall have a vertical gap measuring more than 300 mm nor any vertical surface measuring less than 100 mm; and

- (I) except in the case of a vehicle described in paragraph (1)(c), every sideguard shall be capable of withstanding a force of 2 kilonewtons applied perpendicularly to any part of its surface by the centre of a ram the face of which is circular and not more than 220 mm in diameter, and during such application –
- (i) no part of the sideguard shall be deflected by more than 150 mm, and
 - (ii) no part of the sideguard which is less than 250 mm from its rearmost part shall be deflected by more than 30 mm.

TABLE
(Article 54(6))

1	2	3
<i>Item</i>	<i>Case</i>	<i>Requirements about higher edge of sideguard</i>
1	Where the floor of the vehicle to which the sideguard is fitted – (i) extends laterally outside the tangential plane, (ii) is not more than 1.85 m from the ground, (iii) extends laterally over the whole of the length of the sideguard with which the vehicle is required by this Order to be fitted, and (iv) is wholly covered at its edge by a side-rave the lower edge of which is not more than 150 mm below the underside of the floor	Not more than 350 mm below the lower edge of the side-rave
2	Where the floor of the vehicle to which the sideguard is fitted – (i) extends laterally outside the tangential plane, and (ii) does not comply with all of the provisions specified in subparagraphs (ii), (iii) and (iv) in item 1, and any part of the structure of the vehicle is cut within 1.85 m of the ground by the tangential plane	Not more than 350 mm below the structure of the vehicle where it is cut by the tangential plane
3	Where – (i) no part of the structure of the vehicle is cut within 1.85 m of the ground by the tangential plane, and (ii) the upper surface of the load-carrying structure of the vehicle is less than 1.5 m from the ground	Not less than the height of the upper surface of the load-carrying structure of the vehicle
4	A vehicle specially designed, and not merely adapted, for the carriage and mixing of liquid concrete	Not less than 1 m from the ground

1	2	3
<i>Item</i>	<i>Case</i>	<i>Requirements about higher edge of sideguard</i>
5	Any other case	Not less than 1.5 m from the ground

- (7) The provisions of paragraph (5) apply –
- (a) in the case of an extendable trailer when it is, by virtue of the extending mechanism, extended to a length greater than its minimum, so as not to require, in respect of any additional distance solely attributable to the extension, compliance with the specifications mentioned in paragraph (6)(d) to (g);
 - (b) in the case of a vehicle designed and constructed and not merely adapted, to be fitted with a demountable body or to carry a container, when it is not fitted with a demountable body or carrying such a container as if it were fitted with such a body or carrying such a container; and
 - (c) only so far as it is practicable in the case of –
 - (i) a vehicle designed solely for the carriage of a fluid substance in a closed tank which is permanently fitted to the vehicle and provided with valves and hose or pipe connections for loading or unloading, and
 - (ii) a vehicle which requires additional stability during loading or unloading or while being used for operations for which it is designed or adapted and is fitted on one or both sides with an extendable device to provide such stability.
- (8) In the case of a motor vehicle to which this Article applies and which is of a type which was required to be approved by the Type Approval for Goods Vehicles Regulations before 1st October 1983 –
- (a) if the bodywork of the vehicle covers the whole of the area specified as regards a sideguard in paragraph (6)(b), (c), (d) and (g), the other provisions of that paragraph do not apply to that vehicle; and
 - (b) if the bodywork of the vehicle covers only part of that area the part of that area which is not so covered shall be fitted with a sideguard which complies with the provisions of paragraph (6) save that there shall not be a gap between –
 - (i) the rearmost edge of the sideguard or the rearmost part of the bodywork (whichever is further to the rear) and the transverse plane mentioned in paragraph (6)(d) or more than 300 mm,
 - (ii) the foremost edge of the sideguard or the foremost part of the bodywork (whichever is further to the front) and the transverse plane mentioned in paragraph (6)(g) of more than 300 mm, or
 - (iii) any vertical or sloping edge of any part of the bodywork in question and the edge of the sideguard immediately forwards or rearwards thereof of more than 25 mm measured horizontally.
- (9) In this Article –
- “relevant plate” means a plate fitted in accordance with Article 73;

“relevant train weight” means the maximum train weight shown at item 8 of the plate fitted in accordance with Article 73; and

“tangential plane”, in relation to a sideguard, means the vertical plane tangential to the external face of the outermost part of the tyre (excluding any distortion caused by the weight of the vehicle) fitted to the outermost wheel at the rear and on the same side of the vehicle.

- (10) Instead of complying with this Article a vehicle may comply with Community Directive 89/297.

55 Maintenance of sideguards

- (1) Every sideguard fitted to a vehicle in compliance with the requirements of Article 54 shall at all times when the vehicle is on a road be maintained free from any obvious defect which would be likely to affect adversely its effectiveness.

56 Mascots, ornamental objects, etc.

- (1) No mascot, emblem or other ornamental object shall be carried by a motor vehicle first used on or after 1st October 1937 in any position where it is likely to strike any person with whom the vehicle may collide unless the mascot, emblem or ornamental object is not liable to cause injury to such person by reason of any projection or component thereon.
- (2) Every motor vehicle and all parts and accessories of the vehicle shall at all times be in such condition that no danger is caused or likely to be caused, by reason of any front projection on the vehicle, to any person on or near a road.

57 Strength of superstructure

- (1) This Article applies to every coach which is –
- (a) a single-decked vehicle;
 - (b) equipped with a compartment below the deck for the luggage of passengers; and
 - (c) first used on or after 1st April 1993.
- (2) Every vehicle to which this Article applies shall comply with the requirements of ECE Regulation 66.

58 Additional exits from double-decked coaches

- (1) This Article applies to every coach which is –
- (a) a double-decked vehicle; and
 - (b) first used on or after 1st April 1990.
- (2) Subject to the following provisions of this Article, every vehicle to which this Article applies shall be equipped with 2 staircases, one of which shall be located in one half of the vehicle and the other in the other half of the vehicle.

- (3) Instead of being equipped with 2 staircases in accordance with paragraph (2), a vehicle to which this Article applies may be equipped in accordance with the following provisions of this Article with a hammer or other similar device with which in case of emergency any side window of the vehicle may be broken.
- (4) Where a vehicle is equipped with –
 - (a) a staircase located in one half of the vehicle; and
 - (b) an emergency exit complying with Article 9 of the Public Service Vehicles (Conditions of Fitness) (Jersey) Order 2003 located in the same half of the upper deck of the vehicle,the hammer or the similar device shall be located in the other half of that deck.
- (5) Any hammer or other similar device with which a vehicle is equipped pursuant to this Article shall be located in a conspicuous and readily accessible position in the upper deck of the vehicle.
- (6) There shall be displayed, in a conspicuous position in close proximity to the hammer or other similar device, a notice which shall contain in clear and indelible lettering –
 - (a) in letters not less than 25 mm high, the heading “IN EMERGENCY”; and
 - (b) in letters not less than 10 mm high, instructions that in case of emergency the hammer or device is to be used first to break any side window by striking the glass near the edge of the window and then to clear any remaining glass from the window aperture.
- (7) For the purposes of this Article a staircase, emergency exit, hammer or other similar device (as the case may be) shall be considered to be located in the other half of the vehicle if the shortest distance between any part of the staircase, exit, hammer or device (as the case may be) and any part of any other staircase, emergency exit, hammer or device is not less than one half of the overall length of the vehicle.

K – CONTROL OF EMISSIONS

59 Silencers – general

- (1) Every vehicle propelled by an internal combustion engine shall be fitted with an exhaust system including a silencer and the exhaust gases from the engine shall not escape into the atmosphere without first passing through the silencer.
- (2) Every exhaust system and silencer shall be maintained in good and efficient working order and shall not after the date of manufacture be altered so as to increase the noise made by the escape of exhaust gases.
- (3) Instead of complying with paragraph (1) a vehicle may comply with Community Directive 77/212, 81/334, 84/372 or 84/424 or, in the case of a motor cycle other than a moped, 78/1015.
- (4) In this Article “moped” has the meaning given to it in paragraph 5 of Schedule 11.

60 Noise limits – general

- (1) Save as provided in paragraph (2) and Article 66, this Article applies to every wheeled motor vehicle having at least 3 wheels and first used on or after 1st October 1983 which is –
- (a) a vehicle, not falling within sub-paragraph (b) or (c), with or without bodywork;
 - (b) a vehicle not falling within sub-paragraph (c) which is –
 - (i) engineering plant,
 - (ii) a locomotive other than an agricultural motor vehicle,
 - (iii) a motor tractor other than an industrial tractor or an agricultural motor vehicle,
 - (iv) a public works vehicle,
 - (v) a works truck, or
 - (vi) a refuse vehicle; or
 - (c) a vehicle which –
 - (i) has a compression ignition engine,
 - (ii) is so constructed or adapted that the driving power of the engine is, or by appropriate use of controls can be, transmitted to all wheels of the vehicle, and
 - (iii) falls within category 1.1.1, 1.1.2 or 1.1.3 specified in Article 1 of Community Directive 77/212.
- (2) This Article does not apply to –
- (a) a motor cycle with a sidecar attached;
 - (b) an agricultural motor vehicle which is first used before 1st June 1986 or which is not driven at more than 20 mph;
 - (c) an industrial tractor;
 - (d) a road roller;
 - (e) a vehicle specially constructed, and not merely adapted, for the purpose of fighting fires or salvage from fires at or in the vicinity of airports, and having an engine power exceeding 220 kW;
 - (f) a vehicle which runs on rails.
- (3) Save as provided in paragraphs (4) and (5), every vehicle to which this Article applies shall be so constructed that it complies with the requirements set out in item 1, 2, 3 or 4 of the Table, a vehicle complies with this requirement if –
- (a) its sound level does not exceed the relevant limit specified in column 2(a), (b) or (c), as the case may be, in the relevant item when measured under the conditions specified in column 3 in that item and by the method specified in column 4 in that item using the apparatus prescribed in paragraph (6); and
 - (b) in the case of a vehicle referred to in sub paragraph (1)(a) (other than one having less than 4 wheels or a maximum speed not exceeding 25 km/h) or paragraph (1)(c), the device designed to reduce the exhaust noise meets the requirements specified in column 5 in that item.

TABLE
(Article 60)

1	2			3	4	5
	Limits of sound level					
Item	(a) Vehicle referred to in paragraph (1)(a)	(b) Vehicle referred to in paragraph (1)(b)	(c) Vehicle referred to in paragraph (1)(c)	Conditions of measurement	Method of measurement	Requirements for exhaust devices
1	Limits specified in paragraph I.1. of the Annex to Community Directive 77/212	89dB(A)	82dB(A)	Conditions specified in paragraph 1.3 of the Annex to Community Directive 77/212	Method specified in paragraph 1.4.1 of the Annex to Community Directive 77/212	Requirements specified in heading II of the Annex to Community Directive 77/212 (except paragraphs 11.2 and 11.5)
2	Limits specified in paragraph 5.2.2.1 of Annex I to Community Directive 81/334	89dB(A)	82dB(A)	Conditions specified in paragraph 5.2.2.3 of Annex I to Community Directive 81/334	Method specified in paragraph 5.2.2.4 of Annex I to Community Directive 81/334. Interpretation of results as specified in paragraph 5.2.2.5 of that Annex	Requirements specified in section 3 and paragraphs 5.1 and 5.3.1 of Annex I to Community Directive 81/334
3	Limits specified in paragraph 5.2.2.1 of Annex I to Community Directive 84/372	89dB(A)	82dB(A)	Conditions specified in paragraph 5.2.2.3 of Annex I to Community Directive 84/372	Method specified in paragraph 5.2.2.4 of Annex I to Community Directive 84/372, except that vehicles with 5 or more forward gears and a maximum power to maximum gross weight ratio not less than 75kW per 1,000 kg may be tested in 3rd gear only. Interpretation of results as specified in	Requirements specified in section 3 and paragraphs 5.1 and 5.3.1 of Annex I to Community Directive 84/372

1	2 Limits of sound level			3	4	5
					paragraph 5.2.2.5 of that Annex	
4	Limits specified in paragraph 5.2.2.1 of Annex I to Community Directive 84/424	Vehicles with engine power – less than 75kW – 84dB(A) – not less than 75kW – 86dB(A)	Limits specified in paragraph 5.2.2.1 of Annex I to Community Directive 84/424	Conditions specified in paragraph 5.2.2.3 of Annex I to Community Directive 84/424	Method specified in paragraph 5.2.2.4 of Annex I to Community Directive 84/424, except that vehicles with 5 or more forward gears and a maximum power to maximum gross weight ratio not less than 75kW per 1,000 kg may be tested in 3rd gear only. Interpretation of results as specified in paragraph 5.2.2.5 of that Annex	Requirements specified in section 3 and paragraphs 5.1 and 5.3.1 of Annex I to Community Directive 84/424

- (4) Save as provided in paragraph (5), paragraph (3) applies to every vehicle to which this Article applies and which is first used on or after 1st April 1990, unless it is equipped with 5 or more forward gears and has a maximum power to maximum gross weight ratio not less than 75 kW per 1,000 kg, and is of a type in respect of which a type approval certificate has been issued under the Type Approval (Great Britain) Regulations as if, for the reference to items 1, 2, 3 or 4 of the Table there were substituted a reference to item 4 of the Table.
- (5) Paragraph (4) does not apply to a vehicle in category 5.2.2.1.3 as defined in Annex I to Directive 84/424 and equipped with a compression ignition engine, a vehicle in category 5.2.2.1.4 as defined in that Annex, or a vehicle referred to in paragraph (1)(b) unless it is first used on or after 1st April 1991.
- (6) The apparatus prescribed for the purposes of paragraph (3)(a) and Article 61(2)(a) and Schedule 8 is a sound level meter of the type described in Publication No. 179 of the International Electrotechnical Commission, in either its first or second edition, a sound level meter complying with the specification for Type O or Type 1 in Publication No. 651 (1979) “Sound Level Meters” of the International Electrotechnical Commission, or a sound level meter complying with the specifications of the British Standard Number BS 5969: 1981 which came into effect on 29th May 1981.
- (7) Instead of complying with this Article a vehicle may comply at the time of its first use with Community Directive 77/212, 81/334, 84/372 or 84/424.

61 Noise limits – agricultural motor vehicles and industrial tractors

- (1) Save as provided in Article 66, this Article applies to every wheeled vehicle first used on or after 1st April 1983 being an agricultural motor vehicle or an industrial tractor, other than –
 - (a) an agricultural motor vehicle which is first used on or after 1st June 1986 and which is driven at more than 20 mph; or
 - (b) a road roller.
- (2) Every vehicle to which this Article applies shall be so constructed –
 - (a) that its sound level does not exceed –
 - (i) if it is a vehicle with engine power less than 65 kW, 89dB(A),
 - (ii) if it is a vehicle with engine power of 65 kW or more, and first used before 1st October 1991, 92 dB(A), or
 - (iii) if it is a vehicle with engine power of 65 kW or more, and first used on or after 1st October 1991, 89dB(A),when measured under the conditions specified in paragraph 1.3 of Annex VI to Community Directive 74/151 by the method specified in paragraph 1.4.1 of that Annex using the apparatus prescribed in Article 60(6); and
 - (b) that the device designed to reduce the exhaust noise meets the requirements specified in paragraph II.1 of that Annex and, if fibrous absorbent material is used, the requirements specified in paragraphs 11.4.1 to 11.4.3 of that Annex.

62 Noise limits – motor cycles construction requirements

- (1) Subject to Article 66, this Article applies to every motor vehicle first used on or after 1st April 1983 which is –
 - (a) a moped; or
 - (b) a 2-wheeled motor cycle, whether or not with sidecar attached, which is not a moped.
- (2) A vehicle to which this Article applies shall be so constructed that it meets –
 - (a) if it is used before 1st April 1991, the requirements of item 1 or 2 of the Table in Part 1 of Schedule 8;
 - (b) if it is first used on or after that date, the requirements of item 2 of that Table.
- (3) Instead of complying with paragraph (2), a vehicle first used before 1st April 1991 may comply at the time of its first use with Community Directive 78/1015, 87/56 or 89/235.
- (4) Instead of complying with paragraph (2), a vehicle first used on or after 1st April 1991 may comply at the time of its first use with Community Directive 87/56 or 89/235.
- (5) In this Article “moped” has the meaning given to it in paragraph 5 of Schedule 11.

63 Exhaust systems – motor cycles

- (1) Any original silencer forming part of the exhaust system of a vehicle to which Article 62 applies, being a vehicle first used before 1st February 1996, shall –
 - (a) be so constructed that the vehicle meets the requirements specified in paragraph 3 (other than sub-paragraphs 3.2 and 3.3) of Annex I to Community Directive 78/1015 and be marked in accordance with sub-paragraph 3.3 of that Annex; or
 - (b) be so constructed that the vehicle meets the requirements specified in paragraph 3 (other than sub-paragraphs 3.2 and 3.3) of Annex I to Community Directive 89/235 and be marked in accordance with sub-paragraph 3.3 of that Annex.
- (2) Any original silencer forming part of the exhaust system of a vehicle to which Article 62 applies, being a vehicle first used on or after 1st February 1996, shall be so constructed that the vehicle meets the requirements specified in paragraph 3 (other than sub-paragraphs 3.2 and 3.3) of Annex I to Community Directive 89/235 and be marked in accordance with sub-paragraph 3.3 of that Annex.
- (3) A vehicle fitted with an original silencer may –
 - (a) if the vehicle is first used before 1st February 1996, instead of complying with paragraph (1), comply at the time of first use with Community Directive 78/1015, 87/56 or 89/235; or
 - (b) if the vehicle is first used on or after that date, instead of complying with paragraph (2), comply at the time of first use with Community Directive 89/235.
- (4) Where any replacement silencer forms part of the exhaust system of a vehicle to which Article 62 applies, being a vehicle first used on or after 1st January 1985, the first requirement or the second requirement as set out in paragraphs (5) and (6) must be met in respect of the silencer.
- (5) In order for the requirement to be met in respect of a silencer forming part of the exhaust system of a vehicle (in this paragraph referred to as “the vehicle in question”) –
 - (a) if the vehicle in question is first used before 1st April 1991, the silencer must be so constructed that, were it to be fitted to an unused vehicle of the same model as the vehicle in question, the unused vehicle would meet –
 - (i) the requirements of item 1 or 3 of the Table in Part 1 of Schedule 8, and
 - (ii) the requirements specified in paragraph 3 (other than sub-paragraphs 3.2 and 3.3) of Annex I to Community Directive 78/1015 or 89/235, and the silencer must be marked in accordance with sub-paragraph 3.3 of Annex I to Community Directive 78/1015 or 89/235;
 - (b) if the vehicle in question is first used on or after 1st April 1991 but before 1st February 1996, the silencer must be so constructed that, were it to be fitted to an unused vehicle of the same model as the vehicle in question, the unused vehicle would meet –
 - (i) the requirements of item 3 of the Table in Part 1 of Schedule 8, and

- (ii) the requirements specified in paragraph 3 (other than sub-paragraphs 3.2 and 3.3) of Annex I to Community Directive 78/1015 or 89/235, and the silencer must be marked in accordance with sub-paragraph 3.3 of Annex I to Community Directive 78/1015 or 89/235;
- (c) if the vehicle in question is first used on or after 1st February 1996, the silencer must be so constructed that, were it to be fitted to an unused vehicle of the same model as the vehicle in question, the unused vehicle would meet –
 - (i) the requirements of item 3 of the Table in Part 1 of Schedule 8, and
 - (ii) the requirements specified in paragraph 3 (other than sub-paragraphs 3.2 and 3.3) of Annex I to Community Directive 89/235, and the silencer must be marked in accordance with sub-paragraph 3.3 of Annex I to that Directive.
- (6) In order for the second requirement to be met in respect of a silencer forming part of the exhaust system of a vehicle (in Part 2 of Schedule 8 referred to as “the vehicle in question”) –
 - (a) if the vehicle is first used before 1st April 1991, the silencer must meet the requirements of paragraph 2, 3 or 4 of Part 2 of Schedule 8; or
 - (b) if the vehicle is first used on or after that date, the silencer must meet the requirements of paragraph 4 of Part 2 of Schedule 8.
- (7) Any requirements specified in paragraph (5) or in Part 2 of Schedule 8 relating to the silencer were it to be fitted to an unused vehicle of the same model as the vehicle in question (as defined in that paragraph or in paragraph (6) for the purposes of that Part, as the case may be) shall be deemed to be met if they are met by the silencer as fitted to the vehicle in question at the time that it is first fitted.
- (8) For the purposes of this Article, Community Directive 89/235 shall have effect as if –
 - (a) in Annex I, for sub-paragraph 3.4.1, there were substituted –

“3.4.1 After removal of the fibrous material, the vehicle must meet the relevant requirements”;

and for sub-paragraph 3.4.3 there were substituted –

“3.4.3 After the exhaust system has been put into a normal state for road use by one of the following conditioning methods, the vehicle must meet the relevant requirements”;
 - (b) references in Annex I as so modified to a vehicle meeting the relevant requirements were –
 - (i) in relation to an original silencer, references to a vehicle meeting the requirements of item 2 of the Table in Part 1 of Schedule 8, and
 - (ii) in relation to a replacement silencer, references to a vehicle meeting the requirements of item 3 of that Table;
 - (c) in Annex II there were omitted sub-paragraphs 3.1.2, 3.4 and 3.5 and in sub-paragraph 3.2 –
 - (i) the words “and the name referred to in 3.1.2”; and

- (ii) the words after “legible”.
- (9) For the purposes of paragraph (1)(b) and paragraph (2) in their application to vehicles with a design speed not exceeding 50 km/h, Community Directive 89/235 EEC shall have effect as if it were not only modified in accordance with paragraph (8) but were further modified by the omission of –
- (a) sub-paragraph 3.1.3 of Annex II; and
- (b) in sub-paragraph 3.2 of that Annex, the words “and 3.1.3”.
- (10) In relation to a replacement silencer which is –
- (a) fitted to a vehicle before 1st February 1997; and
- (b) clearly and indelibly marked with the name or trade mark of the manufacturer of the silencer and with that manufacturer’s part number relating to it,
- paragraphs (5) and (6), and Parts II and III of Schedule 8 shall have effect as if they contained no reference to a silencer being marked.
- (11) For the purposes of this Article, a silencer forming part of the exhaust system of a vehicle shall not be regarded as being marked in accordance with sub-paragraph 3.3 of Annex I to Community Directive 78/1015 or 89/235, paragraph (10) of this Article or any paragraph of Part 2 of Schedule 8, if the marking is so obscured by any part of the vehicle that it cannot be easily read.
- (12) Until 1st February 1996 for the purposes of paragraph (6), a vehicle first used on or after 1st April 1991 shall be treated as a vehicle first used before 1st April 1991.
- (13) Part 3 of Schedule 8 shall have effect for the purpose of exempting certain silencers from the provisions of paragraph (4).
- (14) No person shall use a motor cycle on a road or cause or permit such a vehicle to be so used if any part of the exhaust system has been indelibly marked by the manufacturer of that part with the words “NOT FOR ROAD USE” or words to that effect.
- (15) In this Article –
- “original silencer”, in relation to a vehicle, means a silencer which was fitted to the vehicle when it was manufactured;
- “replacement silencer”, in relation to a vehicle, means a silencer fitted to the vehicle, not being an original silencer; and
- “trade mark” has the same meaning as in the [Trade Marks \(Jersey\) Law 2000](#).

64 Noise limits – maintenance requirements relating to motor cycles

- (1) No person shall use or cause or permit to be used on a road a motor cycle to which Article 62 applies if the 3 conditions specified in paragraphs (2) to (4) are all fulfilled.
- (2) The first condition is fulfilled if the vehicle does not meet the noise limit requirements.
- (3) The second condition is fulfilled if –
- (a) any part of the vehicle is not in good and efficient working order; or

- (b) the vehicle has been altered.
- (4) The third condition is fulfilled if the noise made by the vehicle would have been materially less (so far as applicable) –
 - (a) were all parts of the vehicle in good and efficient working order; or
 - (b) had the vehicle not been altered.
- (5) For the purposes of this Article, a vehicle meets the noise limit requirements if –
 - (a) in the case of a vehicle first used before 1st April 1991 and not fitted with a replacement silencer, it meets the requirements of item 1 or 2 of the Table in Part 1 of Schedule 8;
 - (b) in the case of a vehicle first used before 1st April 1991 and fitted with a replacement silencer, it meets the requirements of item 1 or 3 of that Table;
 - (c) in the case of a vehicle first used on or after 1st April 1991 and not fitted with a replacement silencer, it meets the requirements of item 2 of that Table;
 - (d) in the case of a vehicle first used on or after 1st April 1991 and fitted with a replacement silencer, it meets the requirements of item 3 of that Table.
- (6) In this Article, “replacement silencer” has the same meaning as in Article 63.

65 Noise limits – vehicles not subject to Articles 60 to 62 first used on or after 1st April 1970

- (1) Save as provided in paragraph (2) and in Article 66, every wheeled motor vehicle which was first used on or after 1st April 1970 and which is not subject to Article 60, 61 or 62 shall be so constructed that the sound level (A weighting) in decibels does not exceed the maximum permitted level shown in column 2 of the Table for the relevant class of vehicle shown in column 1, when the noise emitted by it is measured under the specified conditions using the prescribed apparatus.
- (2) A vehicle to which this Article applies is not required to comply with paragraph (1) if at the time of its first use it complied with Community Directive 70/157, 73/350 or 77/212 or, in the case of an agricultural motor vehicle 74/151, or if it is –
 - (a) a road roller;
 - (b) a vehicle specially constructed, and not merely adapted, for the purposes of fighting fires or salvage from fires at or in the vicinity of airports, and having an engine power exceeding 220 kW;
 - (c) a vehicle propelled by a compression ignition engine and which is of a type in respect of which a type approval certificate has been issued under the Type Approval (Great Britain) Regulations;
 - (d) a motor cycle first used on or after 1st October 1980, with an engine capacity not exceeding 50 cc which complies with the requirements of item 1 or 2 of the Table in Part 1 of Schedule 8; or
 - (e) an agricultural motor vehicle manufactured on or after 7th February 1975 which complies with the requirements specified in Article 61(2).
- (3) The definition of “sound level (A weighting) in decibels” contained in clause 2 of the British Standard Specification for Sound Level Meters published by the British

Standards Institution on 7th September 1962 under the number BS 3539: 1962, as amended by Amendment Slip No. 1 numbered AMD 22 and published on 1st July 1968, applies for the purposes of this Article.

- (4) In this Article the “specified conditions” means the method described by the British Standard Method for the Measurement of Noise Emitted by Motor Vehicles published on 24th June 1966 under the number BS 3425: 1966.
- (5) In this Article the “prescribed apparatus” means a noise meter –
- (a) which is in good working order and complies with the requirements laid down for vehicle noise meters in Part 1 of the said British Standard Specification numbered BS 3539: 1962, as amended by the said Amendment Slip No. 1;
 - (b) which has, not more than 12 months before the date of the measurement made in accordance with paragraph (1), undergone all the tests for checking calibration applicable in accordance with the appendix to the said British Standard Specification; and
 - (c) in respect of which there has been issued by the National Physical Laboratory, the British Standards Institution or the Secretary of State for Transport of the United Kingdom a certificate recording the date on which as a result of those tests the meter was found to comply with the requirements of clauses 8 and 9 of the said British Standard Specification.

TABLE

(Article 65(1))

1	2	3
<i>Item</i>	<i>Class of vehicle</i>	<i>Maximum permitted sound level in dB (A)</i>
1	Motor cycle of which the cylinder capacity of the engine does not exceed 50 cc	77
2	Motor cycle of which the cylinder capacity of the engine exceeds 50 cc but does not exceed 125 cc	82
3	Motor cycle of which the cylinder capacity of the engine exceeds 125 cc	86
4	Goods vehicle to which Article 73 applies and which is equipped with a plate complying with the requirements of Article 73 and showing particulars of Article 73 and showing particulars of a maximum gross weight of more than 3560 kg	89
5	Motor car not being a goods vehicle of the kind described in item 4	85
6	Motor tractor	89
7	Locomotive	89
8	Agricultural motor vehicle	89
9	Works truck	89
10	Engineering plant	89
11	Passenger vehicle constructed for the carriage of more than 12 passengers exclusive of the driver	89
12	Any other passenger vehicle	84

1	2	3
<i>Item</i>	<i>Class of vehicle</i>	<i>Maximum permitted sound level in dB (A)</i>
13	Any other vehicle	85

66 Exceptions to Articles 60 and 65

Articles 60, 61, 63, 64 and 65 do not apply to a motor vehicle which is –

- (a) proceeding to a place where, by previous arrangement –
 - (i) noise emitted by it is about to be measured for the purpose of ascertaining whether or not the vehicle complies with such of those provisions as apply to it, or
 - (ii) the vehicle is about to be mechanically adjusted, modified or equipped for the purpose of securing that it so complies; or
- (b) returning from such a place immediately after the noise has been measured.

67 Radio interference suppression

- (1) Save as provided in paragraph (2), every wheeled motor vehicle first used on or after 1st April 1974 which is propelled by a spark ignition engine shall comply at the time of its first use with Community Directive 72/245 or ECE Regulation 10 or 10.01 or, in the case of an agricultural motor vehicle, Community Directive 75/322.
- (2) This Article does not apply to a vehicle constructed or assembled by a person not ordinarily engaged in the trade or business of manufacturing vehicles of that description, but nothing in this paragraph affects the application to such vehicles of the Wireless Telegraphy (Control of Interference from Ignition Apparatus) Regulations 1973 of the United Kingdom.

68 Emission of smoke, vapour, gases, oily substances, etc.

- (1) Subject to paragraph (5), every vehicle shall be constructed and maintained so as not to emit any avoidable smoke or avoidable visible vapour.
- (2) Every motor vehicle using solid fuel shall be fitted with –
 - (a) a tray or shield to prevent ashes and cinders from falling onto the road; and
 - (b) an efficient appliance to prevent any emission of sparks or grit.
- (3) Subject to paragraph (7) and to the exemptions specified in an item in column 4 of Table 1 every wheeled vehicle of a class specified in that item in column 2 shall be constructed so as to comply with the requirements specified in that item in column 3.
- (4) A motor vehicle to which an item in Table 2 applies shall be so constructed as to comply with the requirements relating to conformity of production models set out in the provisions specified in that item in column (4) of that Table.
- (5) Instead of complying with paragraph (1) a vehicle may comply with a relevant instrument.

- (6) Instead of complying with such provisions of items 1, 2 and 3 in Table 1 as apply to it, a vehicle may at the time of its first use comply with a relevant instrument.
- (7) For the purposes of paragraphs (5) and (6), a reference to a vehicle complying with a relevant instrument is a reference to a vehicle complying –
 - (a) if it is propelled by a compression ignition engine, with Community Directive 72/306 (or, in the case of an agricultural vehicle, 77/537) or ECE Regulation 24.01, 24.02 or 24.03; or
 - (b) if it is propelled by a spark ignition engine with any instrument mentioned in column (4)(a) of Table 2.
- (8) No person shall use, or cause or permit to be used, on a road a motor vehicle –
 - (a) from which any smoke, visible vapour, grit, sparks, ashes, cinders or oily substance is emitted if that emission causes, or is likely to cause, damage to any property or injury or danger to any person who is, or who may reasonably be expected to be, on the road;
 - (b) which is subject to the requirement in item 2 of Table 1 (whether or not it is deemed to comply with the requirement by virtue of paragraph (7)) if the fuel injection equipment, the engine speed governor or any other parts of the engine by which it is propelled have been altered or adjusted so as to increase the emission of smoke; or
 - (c) which is subject to the requirement in item 1 of Table 1 if the device mentioned in column 2 in that item is used while the vehicle is in motion.
- (9) No person shall use, or cause or permit to be used, on a road a motor vehicle to which item 3 of Table 1 applies unless it is so maintained that the means specified in column 3 of that item are in good working order.
- (10) Subject to paragraphs (11) to (18) and (19) to (21), no person shall use, or cause or permit to be used, on a road a motor vehicle to which an item in Table 2 applies if, in relation to the emission of the substances specified in column (6) of the item, the vehicle does not comply with the requirements relating to conformity of production models specified in column (4) unless the following conditions are satisfied in respect to it –
 - (a) the failure to meet those requirements in relation to the emission of those substances does not result from an alteration to the propulsion unit or exhaust system of the vehicle;
 - (b) neither would those requirements be met in relation to the emission of those substances nor would such emissions be materially reduced if maintenance work of a kind which would fall within the scope of a normal periodic service of the vehicle were to be carried out on the vehicle; and
 - (c) the failure to meet those requirements in relation to such emissions does not result from any device designed to control the emission of carbon monoxide, hydrocarbons, oxides of nitrogen or particulates fitted to the vehicle being other than in good and efficient working order.
- (11) In relation to a vehicle to which Part 3 of Schedule 1B of the Type Approval (Great Britain) Regulations applies, item 8 of Table 2 shall have effect as if for the entry in column (3) there were substituted “31st December 1993”.

- (12) In relation to a vehicle to which Part 3 of Schedule 1B of the Type Approval for Goods Vehicles Regulations applies, item 9 of Table 2 shall have effect as if for the entry in column (3) there were substituted “1st October 1994”.
- (13) In relation to a vehicle to which neither the Type Approval for Goods Vehicles Regulations nor the Type Approval (Great Britain) Regulations applies, and which was one among the first specified number of relevant vehicles to have been manufactured, item 9 of Table 2 shall have effect as if for the entry in column (3) there were substituted “1st October 1994”.
- (14) For the purposes of paragraph (13), in relation to a vehicle (“the vehicle in question”) –
- (a) “specified number” is 10% of the total number of vehicles to which neither the Type Approval for Goods Vehicles Regulations nor the Type Approval (Great Britain) Regulations applies that were both –
- (i) manufactured by the manufacturer of the vehicle in question, and
- (ii) registered under the 1993 Law during the period beginning with 1st January 1994 and ending with 30th September 1994,
- or 50, whichever is the greater; and
- (b) a “relevant vehicle” is a vehicle which –
- (i) is not subject to either the Type Approval for Goods Vehicles Regulations or the Type Approval (Great Britain) Regulations,
- (ii) was manufactured by the manufacturer of the vehicle in question on or after 1st April 1991 and before 1st October 1993,
- (iii) was in the territory of a member State at some time before 1st October 1993,
- (iv) was in existence on 1st October 1993, but
- (v) had not been registered under the 1993 Law before 1st October 1994.
- (15) In relation to a vehicle to which either Part 4 of Schedule 1B of the Type Approval (Great Britain) Regulations or Part 4 of the Type Approval for Goods Vehicles Regulations applies, item 11 of Table 2 shall have effect as if for the entry in column (3) there were substituted “1st October 1995”.
- (16) In relation to a vehicle to which neither the Type Approval (Great Britain) Regulations nor the Type Approval for Goods Vehicles Regulations applies, and which was one among the first specified number of relevant vehicles to have been manufactured, item 11 of Table 2 shall have effect as if for the entry in column (3) there were substituted “1st October 1995”.
- (17) For the purposes of paragraph (16), in relation to a vehicle (the “vehicle in question”) –
- (a) “specified number” is 10% of the total number of vehicles to which neither the Type Approval (Great Britain) Regulations nor the Type Approval for Goods Vehicles Regulations applies that were both –
- (i) manufactured by the manufacturer of the vehicle in question, and
- (ii) registered under the 1993 Law during the period beginning with 1st October 1994 and ending with 30th September 1995,

or 50, whichever is the greater; and

- (b) a “relevant vehicle” is a vehicle to which neither the Type Approval (Great Britain) Regulations nor the Type Approval for Goods Vehicles Regulations apply and which –
- (i) was manufactured by the manufacturer of the vehicle in question on or after 1st August 1992 and before 1st August 1994,
 - (ii) was in the territory of an EEA State at some time before 1st October 1994,
 - (iii) was in existence on 1st October 1994, but
 - (iv) had not been registered under the 1993 Law before 1st October 1994.
- (18) In paragraph (17) “EEA State” means a State which is a Contracting Party to the Agreement on the European Economic Area signed at Oporto on 2nd May 1992 as adjusted by the Protocol signed at Brussels on 17th March 1993, but until that Agreement comes into force in relation to Liechtenstein does not include the State of Liechtenstein.
- (19) Paragraph (10) shall apply to a vehicle first used before 26th June 1990.
- (20) Where –
- (a) a vehicle is fitted with a device of the kind referred to in paragraph (10)(c);
 - (b) the vehicle does not comply with the requirements specified in that paragraph in respect to it; and
 - (c) the conditions specified in sub-paragraphs (a) and (b) of that paragraph are satisfied in respect to the vehicle,
- nothing in paragraph (10) shall prevent the vehicle being driven to a place where the device is to be repaired and replaced.
- (21) Where a vehicle is constructed or assembled by a person not ordinarily engaged in the business of manufacturing motor vehicles of that description, the date on which it is first used shall, for the purposes of paragraphs (4), (10), (19) and (20) be regarded as being the 1st January immediately preceding the date of manufacture of the engine by which it is propelled. However, the date on which a vehicle is first used shall not, by virtue of this paragraph, be regarded in any circumstances as being later than the date on which it would otherwise have been regarded as being first used had those provisions been omitted.
- (22) Without prejudice to paragraphs (1) and (10) and subject to this Article no person shall use, or cause or permit to be used on a road, a vehicle first used on or after 1st August 1975 and propelled by a four-stroke spark ignition engine, if the vehicle is in such a condition and running on such fuel that –
- (a) when the engine is idling the carbon monoxide content of the exhaust emissions from the engine exceeds –
 - (i) in the case of a vehicle first used before 1st August 1986, 4.5%, or
 - (ii) in any other case, 3.5%,of the total exhaust emissions from the engine by volume; and

- (b) when the engine is running without load at a rotational speed of 2,000 revolutions per minute the hydrocarbon content of those emissions exceeds 0.12% of the total exhaust emissions from the engine by volume.
- (23) Without prejudice to paragraphs (1) and (10) and subject to this Article, no person shall use, or cause or permit to be used on a road, a vehicle to which this paragraph applies and which is propelled by a spark ignition engine, if the vehicle is in such a condition and running on such fuel that Part 1 of Schedule 9 applies to the vehicle.
- (24) Subject to paragraph (26), paragraph (23) applies to –
- (a) a passenger car which –
- (i) is first used on or after 1st April 1992 and before 1st August 1994, and
- (ii) is of a description mentioned in the Annex to the emissions publications;
- (b) a vehicle which –
- (i) is not a passenger car,
- (ii) is first used on or after 1st August 1994, and
- (iii) is of a description mentioned in the Annex to the emissions publication; or
- (c) a passenger car which is first used on or after 1st August 1994;
- and in this paragraph, “emissions publications” has the meaning given in Part 1 of Schedule 9.
- (25) Paragraph (22) does not apply to a vehicle to which paragraph (23) applies.
- (26) Paragraph (22) does not apply to –
- (a) a vehicle to which paragraph (23) applies; or
- (b) a vehicle if, at the date that the engine was manufactured, that engine was incapable of meeting the requirements specified in that paragraph.
- (27) Paragraph (23) does not apply to a vehicle if, at the date that the engine was manufactured, that engine was incapable of meeting the requirements specified in that paragraph.
- (28) Paragraphs (22) and (23) do not apply to –
- (a) a vehicle being driven to a place where it is to undergo repairs;
- (b) a vehicle which was constructed or assembled by a person not ordinarily engaged in the business of manufacturing motor vehicles of that description;
- (c) an exempt vehicle within the meaning given by paragraph (32)(a);
- (d) a goods vehicle with a maximum gross weight exceeding 3,500 kg;
- (e) engineering plant, an industrial tractor, or a works truck; or
- (f) a vehicle first used before 1st August 1987 if the engine is a rotary piston engine; and for the purposes of this paragraph “the engine”, in relation to a vehicle, means the engine by which it is propelled.
- (29) Without prejudice to paragraphs (1) and (10), no person shall use, or cause or permit to be used on a road, a vehicle propelled by a compression ignition engine,

if the vehicle is in such a condition and running on such fuel that Part 2 of Schedule 9 applies to the vehicle.

- (30) Paragraph (29) shall not apply to –
- (a) a vehicle, if at the date that the engine was manufactured, that engine was incapable of meeting the requirements specified in that paragraph;
 - (b) a vehicle being driven to a place where it is to undergo repairs;
 - (c) an exempt vehicle within the meaning given by paragraph (32)(a); and
 - (d) engineering plant, an industrial tractor or a works truck.
- (31) For the purposes of this Article –
- (a) any rotary piston engine shall be deemed to be a 4-stroke engine; and
 - (b) “rotary piston engine” means an engine in which the torque is provided by means of one or more rotary pistons and not by any reciprocating piston.
- (32) In this Article, a reference to a vehicle to which an item in Table 2 applies is a reference to a vehicle which –
- (a) is of a class specified in that item in column (2) of that Table;
 - (b) is first used on or after the date specified in that item in column (3) of that Table; and
 - (c) is not exempted by the entry in that item in column (5) of that Table and for the purposes of determining whether a vehicle is a vehicle to which any item numbered 8 or more in that Table applies, Article 2(2) shall be disregarded.
- (33) In this Article “passenger car” means a motor vehicle which –
- (a) is constructed or adapted for use for the carriage of passengers and is not a goods vehicle;
 - (b) has no more than 5 seats in addition to the driver’s seat; and
 - (c) has a maximum gross weight not exceeding 2,500 kg.
- (34) In Table 2 –
- (a) “exempt vehicle” means –
 - (i) a vehicle with less than 4 wheels,
 - (ii) a vehicle with a maximum gross weight of less than 400 kg,
 - (iii) a vehicle with a maximum speed of less than 25 km/h, or
 - (iv) an agricultural motor vehicle;
 - (b) “direct injection” means a fuel injection system in which the injector communicates with an open combustion chamber or the main part of a divided combustion chamber;
 - (c) “indirect injection” means a fuel injection system in which the injector communicates with the subsidiary part of a divided combustion chamber;
 - (d) a reference in column (5) to a vehicle complying with an item is a reference to a vehicle that complies with the provisions specified in that item in column (4) whether the vehicle is or is not within the class of vehicles to which that item applies and any instrument mentioned in that item shall for

the purposes of the reference have effect as if it applied to the vehicle in question (whether it would otherwise have done so or not).

TABLE 1
(Article 68(3))

1	2	3	4
<i>Item</i>	<i>Class of vehicle</i>	<i>Requirements</i>	<i>Exemptions</i>
1	Vehicles propelled by a compression ignition engine and equipped with a device designed to facilitate starting the engine by causing it to be supplied with excess fuel	Provision shall be made to ensure the device cannot readily be operated by a person inside the vehicle	(a) a works truck; (b) a vehicle on which the device is so designed and maintained that – (i) its use after the engine has started cannot cause the engine to be supplied with excess fuel, or (ii) it does not cause any increase in the smoke or visible vapour emitted from the vehicle
2	Vehicles first used on or after 1st April 1973 and propelled by a compression ignition engine	The engine of the vehicle shall be of a type for which there has been issued by a person authorized by the Secretary of State for Transport of the United Kingdom a type test certificated in accordance with the British Standard Specification for the Performance of Diesel Engines for Road Vehicles published on 19th May 1971 under number BS AU 141a: 1971. In the case of an agricultural motor vehicle (other than one which is first used after 1st June 1986 and is driven at more than 20 mph), an industrial tractor, a works truck or	(a) A vehicle manufactured before 1st April 1973 and propelled by an engine known as the Perkins 6.354 engine; (b) a vehicle propelled by an engine having not more than 2 cylinders and being an agricultural motor vehicle (other than one which is first used on or after 1st June 1986 and which is driven at more than 20 mph), an industrial tractor, a works truck or engineering plant

1	2	3	4
<i>Item</i>	<i>Class of vehicle</i>	<i>Requirements</i>	<i>Exemptions</i>
		engineering plant, for the purposes of that Specification as to the exhaust gas capacity, measurements shall be made with the engine running at 80% of its full load over the speed range from maximum speed down to the speed at which maximum torque occurs as declared by the manufacturer of the vehicle for those purposes	
3	Vehicles first used on or after 1st January 1972 and propelled by a spark ignition engine other than a 2-stroke engine	The engine shall be equipped with means sufficient to ensure that, while the engine is running, any vapours or gases in the engine crank case, or in any other part of the engine to which vapours or gases may pass from that case, are prevented, so far as is reasonably practicable, from escaping into the atmosphere otherwise than through the combustion chamber of the engine	(a) a two-wheeled motor cycle with or without a sidecar attached; (b) a vehicle to which any item in Table 2 applies

TABLE 2

(Article 68(4), (6), (10), (11), (12), (13), (15), (16), (30) and (32))

(1) Item	(2) Class of vehicle	(3) Date of first use	(4) Design, construction and equipment requirements		(5) Vehicles exempted from requirement	(6) Emitted substances
			(a) Instrument	(b) Place in Instrument where requirements are stated		
1	Vehicles propelled by a spark ignition engine	1st October 1982	Community Directive 78/665, or ECE Regulation 15.03	Annex I, paragraphs 3 and 5 Paragraphs 5, 8 and 11	(a) A vehicle whose maximum gross weight exceeds 3,500 kg; (b) a vehicle which complies with the requirements of items 2, 4, 5, 8, 11 and 12; (c) a vehicle whose maximum speed is less than 50 km/h; (d) an exempt vehicle	Carbon monoxide hydrocarbons and oxides of nitrogen
2	All vehicles	1st April 1991	Community Directive 83/351, or ECE Regulation 15.04	Annex I, paragraphs 5, 7 and 8 Paragraphs 5, 8 and 12	(a) A vehicle propelled by a compression ignition engine and whose maximum gross weight exceeds 3,500 kg; (b) a vehicle which complies with the requirements of items 4, 5, 8, 11 and 12; (c) a vehicle within the meaning given by Article 1 of Community Directive 88/77 and which complies with the requirements of item 6,9 or 10; (d) an industrial tractor, works truck or engineering plant; (e) a vehicle whose maximum speed is less than 50 km/h; (f) an exempt vehicle	Carbon monoxide hydrocarbons and oxides of nitrogen
3	Industrial tractors, works trucks and engineering plant	1st April 1993	ECE Regulation 49	Paragraphs 5 and 7	A vehicle which complies with the requirements of item 6,	Carbon monoxide hydrocarbons and oxides of nitrogen

(1)	(2)	(3)	(4)		(5)	(6)
Item	Class of vehicle	Date of first use	Design, construction and equipment requirements		Vehicles exempted from requirement	Emitted substances
	propelled in each case by a compression ignition engine				9, 10, 11 or 12	
4	Passenger vehicles which – (a) are constructed or adapted to carry more than 5 passengers excluding the driver; and (b) have a maximum gross weight of not more than 2,500 kg, not being off-road vehicles	1st April 1991	Community Directive 88/76, or Community Directive 89/458, or ECE Regulation 83	Annex I, paragraphs 5, 7 and 8 Annex I, paragraphs 5, 7 and 8 Paragraphs 5, 8 and 13	(a) A vehicle which complies with the requirements of item 2, 8, 11 or 12; (b) a vehicle whose maximum speed is less than 50 km/h; (c) an exempt vehicle	Carbon monoxide hydrocarbons and oxides of nitrogen
5	Vehicles which are not of a description specified in this column in item 4 but which – (a) are propelled by a spark ignition engine and have a maximum gross weight of not more than 2,000 kg; or (b) are propelled by a compression ignition engine and have a maximum gross weight of more than 3,500 kg	1st April 1992	Community Directive 88/76, or ECE Regulation 83	Annex I, paragraphs 5, 7 and 8	(a) A vehicle within the meaning given by Article 1 of Community Directive 88/77 and which complies with the requirements of item 6, 9, 10, 11 or 12; (b) an industrial tractor, works truck or engineering plant; (c) a vehicle whose maximum speed is less than 50 km/h; (d) a vehicle which complies with the requirements of item 8; (e) an exempt vehicle	Carbon monoxide hydrocarbons and oxides of nitrogen
6	All vehicles propelled by compression ignition engines	1st April 1991	Community Directive 88/77, or ECE Regulation	Annex I, paragraph 6, 7 and 8 Paragraphs 5, 6 and 7	(a) A vehicle whose maximum gross weight is less than 3,500 kg and which complies	Carbon monoxide hydrocarbons and oxides of nitrogen

(1)	(2)	(3)	(4)		(5)	(6)
Item	Class of vehicle	Date of first use	Design, construction and equipment requirements		Vehicles exempted from requirement	Emitted substances
			49.01		with the requirements of item 2; (b) a vehicle which complies with the requirements of item 4, 5, 8, 9, 10, 11 or 12; (c) a fire appliance which is first used before 1st October 1992; (d) an industrial tractor, works truck or engineering plant; (e) an exempt vehicle	
7	Passenger vehicles which – (a) are constructed or adapted to carry not more than 5 excluding the driver; (b) have a maximum gross weight of not more than 2,500 kg; and (c) are propelled by a compression ignition engine of the indirect injection type	1st April 1991	Community Directive 88/436	Annex I, paragraphs 5, 7 and 8, as far as they relate to particular emissions	(a) A vehicle which complies with the requirements of item 8, 11 or 12; (b) a vehicle whose maximum speed is less than 50 km/h; (c) an off-road vehicle; (d) an exempt vehicle	Particulates

(1)	(2)	(3)	(4)		(5)	(6)
Item	Class of vehicle	Date of first use	Design, construction and equipment requirements		Vehicles exempted from requirement	Emitted substances
8	All vehicles	31st December 1992	Community Directive 91/441, or ECE Regulation 83.01	Annex I, paragraphs 5, 7 and 8 Paragraphs 5, 8 and 13	(a) A vehicle within the meaning given by Article 1 of Community Directive 88/77 and which – <ul style="list-style-type: none"> (i) complies with the requirements of item 6 and is first used before 1st October 1993; or (ii) complies with the requirements of item 9, 10, 11 or 12; (b) an industrial tractor, works truck or engineering plant; (c) a vehicle whose maximum speed is less than 50 km/h; (d) an exempt vehicle	Carbon monoxide hydrocarbons, oxides of nitrogen, particulates
9	All vehicles propelled by a compression ignition engine	1st October 1993	Community Directive 91/542, or ECE Regulation 49.02	Annex I, paragraphs 6, 7 and 8 (excluding line B in the Tables in subparagraphs 6.2.1 and 8.3.1.1) Paragraphs 5, 6 and 7 (excluding line B in the Tables in subparagraphs 5.2.1 and 7.4.2.1)	(a) A vehicle which complies with the requirements of item 8, 10, 11 or 12; (b) an industrial tractor, works truck or engineering plant; (c) an exempt vehicle	Carbon monoxide hydrocarbons, oxides of nitrogen and particulates

(1)	(2)	(3)	(4)		(5)	(6)
Item	Class of vehicle	Date of first use	Design, construction and equipment requirements		Vehicles exempted from requirement	Emitted substances
10	All vehicles propelled by a compression ignition engine	1st October 1996	Community Directive 91/542 or ECE Regulation 49.02	Annex I, paragraphs 6, 7 and 8 (excluding line A in the Tables in subparagraphs 6.2.1 and 8.3.1.1) Paragraphs 5, 6 and 7 (excluding line B in the Tables in subparagraphs 5.2.1 and 7.4.2.1)	(a) A vehicle which complies with requirements of item 8, 11 or 12; (b) an industrial tractor, works truck or engineering plant; (c) an exempt vehicle	Carbon monoxide hydrocarbons, oxides of nitrogen and particulates
11	All vehicles	1st October 1994	Community Directive 93/59	Annex I, paragraphs 5, 7 and 8	(a) A vehicle within the meaning given by Article 1 of Community Directive 88/77 and which complies with the requirements of item 9, 10 or 12; (b) an industrial tractor, works truck or engineering plant; (c) vehicles whose maximum speed is less than 50 km/h; (d) an exempt vehicle	Carbon monoxide hydrocarbons, oxides of nitrogen and particulates
12	All vehicles	1st January 199	Community Directive 94/12	Annex I, paragraphs 5, 7 and 8	(a) A vehicle within the meaning given by Article 1 of Community Directive 88/77 and which complies with the requirements of item 9, 10 or 11; (b) an industrial tractor, works truck or engineering plant; (c) vehicles whose maximum speed is less than 50 km/h; (d) an exempt vehicle	Carbon monoxide hydrocarbons, oxides of nitrogen and particulates

69 Closets etc.

- (1) No wheeled vehicle first used on or after 15th January 1931 shall be equipped with any closet or urinal which can discharge directly on to a road.
- (2) Every tank into which a closet or urinal with which a vehicle is equipped empties, and every closet or urinal which does not empty into a tank, shall contain chemicals which are non-flammable and non-irritant and provide an efficient germicide.¹⁷

70 Wings

- (1) Save as provided in paragraph (4), this Article applies to –
 - (a) invalid carriages;
 - (b) heavy motor cars, motor cars and motor cycles, not being agricultural motor vehicles or pedestrian-controlled vehicles;
 - (c) agricultural motor vehicles driven at more than 20 mph; and
 - (d) trailers.
- (2) Subject to paragraphs (3) and (5), every vehicle to which this Article applies shall be equipped with wings or other similar fittings to catch, so far as practicable, mud or water thrown up by the rotation of its wheels or tracks.
- (3) The requirements specified in paragraph (2) apply, in the case of a trailer with more than 2 wheels, only in respect of the rearmost 2 wheels.
- (4) Those requirements do not apply in respect of –
 - (a) a works truck;
 - (b) a living van;
 - (c) a water cart;
 - (d) an agricultural trailer drawn by a motor vehicle which is not driven at a speed in excess of 20 mph;
 - (e) an agricultural trailed appliance;
 - (f) an agricultural trailed appliance conveyer;
 - (g) a broken-down vehicle;
 - (h) a heavy motor car, motor car or trailer in an unfinished condition which is proceeding to a workshop for completion;
 - (i) a trailer used for or in connection with the carriage of round timber and the rear wheels of any heavy motor car or motor car drawing a semi-trailer so used; or
 - (j) a trailer drawn by a motor vehicle the maximum speed of which is restricted at 20 mph or less under the Law.
- (5) Instead of complying with paragraph (2) a vehicle may comply with Community Directive 78/549.

71 Spray suppression devices

- (1) Save as provided in paragraph (2), this Article applies to every wheeled goods vehicle which is –
 - (a) a motor vehicle first used on or after 1st January 1999 having a maximum gross weight not exceeding 12,000 kg;
 - (b) a trailer manufactured on or after 1st January 1999 having a maximum gross weight exceeding 3,500 kg; or
 - (c) a trailer, whenever manufactured, having a maximum gross weight exceeding 16,000 kg and 2 or more axles.
- (2) This Article does not apply to –
 - (a) a motor vehicle so constructed that the driving power of its engine is, or can by use of its controls be, transmitted to all the wheels on at least one front axle and on at least one rear axle;
 - (b) a motor vehicle of which no part which lies within the specified area is less than 400 mm vertically above the ground when the vehicle is standing on reasonably flat ground;
 - (c) a works truck;
 - (d) a works trailer;
 - (e) a broken-down vehicle;
 - (f) a vehicle which has a maximum permitted speed not exceeding 30 mph;
 - (g) a vehicle of a kind specified in Article 54(2)(b), (c), (d), (e), (f), (g), (h), (j), (k), (o) or (p);
 - (h) a vehicle specially designed, and not merely adapted, for the carriage and mixing of liquid concrete; or
 - (i) a vehicle which is being driven or towed to a place where by previous arrangement a device is to be fitted so that it complies with the requirements specified in paragraph (3).
- (3) This Article shall not apply to a vehicle fitted with a spray-suppression system in accordance with the requirements of Annex III of Community Directive 91/226 if the spray suppression devices with which the vehicle is equipped are legibly and permanently marked with a designated approval mark.
- (4) A vehicle to which this Article applies and which is of a class specified in an item in column 2 of the Table shall not be used on a road on or after the date specified in column 3 in that item, unless it is fitted in relation to the wheels on each of its axles, with such containment devices as satisfy the technical requirements and other provisions about containment devices specified in the British Standard Specification, provided that in the case of a containment device fitted before 1st January 1985 the said requirements shall be deemed to be complied with if that containment device substantially conforms to those requirements.

TABLE
(Article 71(4))

1	2	3
<i>Item</i>	<i>Class of vehicle</i>	<i>Date</i>
1	A trailer manufactured before 1st January 1975	1st October 1999
2	A trailer manufactured on or after 1st January 1975 but before 1st January 199	1st October 1998
3	A trailer manufactured on or after 1st January 199	1st January 199 ¹⁸
4	A motor vehicle	1st January 1999

(5) In this Article –

“British Standard Specification” means –

- (a) in relation to a containment device fitted before 1st January 1996, Part 1a of the amended Specification; and
- (b) in relation to a containment device fitted on or after 1st January 1996, Part 1a and Part 2a of the amended Specification;

“designated approval mark” means the marking designated as an Approval Mark by regulation 5 of the Approval Marks Regulations and shown at item 30 in Schedule 4 to those Regulations;

“original Specification” means the British Standard Specification for Spray Reducing Devices for Heavy Goods Vehicles published under the reference BS AU 200: Part 1: 1984 and BS AU 200: Part 2: 1984;

“amended Specification” means the original Specification amended and published under the reference BS AU 200: Part 1a: 1986 and BS AU 200: Part 2a: 1986;

“containment device” means any device so described in the original Specification or the amended Specification;

“specified area” means the area formed by the overall length of the vehicle and the middle 80% of the shortest distance between the inner edges of any 2 wheels on opposite sides of the vehicle (such distance being ascertained when the vehicle is fitted with suitable tyres inflated to a pressure recommended by the manufacturer, but excluding any bulging of the tyres near the ground).

(6) Nothing in this Article derogates from any requirement specified in Article 70.

72 Maintenance of spray suppression devices

Every part of every containment device with which a vehicle is required to be fitted by the provisions of Article 71 shall at all times when the vehicle is on a road be maintained free from any obvious defect which would be likely to affect adversely the effectiveness of the device.

PART 3**PLATES AND MARKINGS****73 Plates for goods vehicles and buses**

- (1) This Article applies to –
- (a) a wheeled heavy motor car or motor car first used on or after 1st January 1968 not being –
 - (i) a dual-purpose vehicle,
 - (ii) an agricultural motor vehicle,
 - (iii) a works truck,
 - (iv) a pedestrian-controlled vehicle, or
 - (v) save as provided in sub-paragraph (b), a passenger vehicle;
 - (b) a bus (whether or not it is an articulated bus) first used on or after 1st April 1982;
 - (c) a wheeled locomotive or motor tractor first used on or after 1st April 1973 not being –
 - (i) an agricultural motor vehicle,
 - (ii) an industrial tractor,
 - (iii) a works truck,
 - (iv) engineering plant, or
 - (v) a pedestrian-controlled vehicle;
 - (d) a wheeled trailer manufactured on or after 1st January 1968 which exceeds 1020 kg in weight unladen not being –
 - (i) a trailer not constructed or adapted to carry any load, other than plant or special appliances or apparatus which is a permanent or essentially permanent fixture, and not exceeding 2290 kg in total weight,
 - (ii) a living van not exceeding 2040 kg in weight unladen and fitted with pneumatic tyres,
 - (iii) a works trailer,
 - (iv) a trailer mentioned in Article 16(3)(b) to (f), or
 - (v) a trailer which was used outside Jersey before it was first used in Jersey;
 - (e) a converter dolly manufactured on or after 1st January 1979.
- (2) Every vehicle to which this Article applies shall be equipped with a plate securely attached to the vehicle in a conspicuous and readily accessible position which either –
- (a) contains the particulars required, in the case of a motor vehicle by Part 1 of Schedule 10 or, in the case of a trailer, by Part 2 of that Schedule, and complies with the provisions of Part 3 of that Schedule; or

- (b) complies with the requirements specified in the Annex to Community Directive 78/507 or, in the case of a vehicle first used before 1st October 1982, in the Annex to Community Directive 76/114, such requirements being in any case modified as provided in paragraph (3).
- (3) Instead of the particulars required by items 2.1.4 to 2.1.7 of that Annex, the plate required by paragraph (2)(b) shall show, for a vehicle of a class specified in column 2 of that Table against an item of that Annex so specified in column 1, the following particulars –
- (a) the maximum permitted weight for that class, if any, shown in column 3 of the Table;
- (b) where the maximum weight shown in column 4 of the Table exceeds the maximum permitted weight, the maximum weight in a column on the plate to the right of the maximum permitted weight; and
- (c) if no weight is shown in column 3 of the Table, the maximum weight shown in column 4 of the Table, in the right-hand column of the plate.

TABLE

(Article 73(3))

1	2	3	4
<i>Item in Annex to Directive</i>	<i>Class of vehicle</i>	<i>Maximum permitted weight</i>	<i>Maximum weight</i>
2.1.4 (Laden weight of vehicle)	(i) Motor vehicles (ii) Trailers, other than semi-trailers (iii) Semi-trailers	The maximum gross weight referred to in item 7 in Part 1 of Schedule 10 The maximum gross weight referred to in item 6 in Part 2 of Schedule 10	The maximum gross weight referred to in item 7 in Part 1 of Schedule 10 The maximum gross weight referred to in item 6 in Part 2 of Schedule 10 The maximum gross weight referred to in item 6 of Part 2 of Schedule 10
2.1.5 (Train weight of motor vehicle)	Motor vehicles constructed to draw a trailer	The lower of – (a) The maximum train weight referred to in item 8 in Part 1 of Schedule 10; and (b) the maximum laden weight specified, in the case of vehicles constructed to form part of	The maximum train weight referred to in item 8 in Part 1 of Schedule 10

1	2	3	4
<i>Item in Annex to Directive</i>	<i>Class of vehicle</i>	<i>Maximum permitted weight</i>	<i>Maximum weight</i>
		an articulated vehicle, in Article 83 and, in other cases in Article 82	
2.1.6 (Axle weight of vehicle)	(i) Motor vehicles	The maximum weight for each axle referred to in item 6 in Part 1 of Schedule 10	The maximum weight for each axle referred to in item 6 in Part 1 of Schedule 10
	(ii) Trailers	The maximum weight for each axle referred to in item 4 in Part 2 of Schedule 10	The maximum weight for each axle referred to in item 4 in Part 2 of Schedule 10
2.1.7 (Load imposed by semi-trailer)	Semi-trailers		The maximum load imposed on the drawing vehicle referred to in item 5 in Part 2 of Schedule 10

- (4) Part 3 of Schedule 10 applies for determining the relevant weights to be shown on a plate in accordance with this Article.

74 Vehicle identification number

- (1) This Article applies to a wheeled vehicle which is first used on or after 1st April 1980 and to which the Type Approval (Great Britain) Regulations apply.
- (2) A vehicle to which this Article applies shall be equipped with a plate which is in a conspicuous and readily accessible position, is affixed to a vehicle part which is not normally subject to replacement and shows clearly and indelibly –
- (a) the vehicle identification number in accordance with the requirements specified –
 - (i) in the case of a vehicle first used before 1st April 1987, in paragraphs 3.1.1 and 3.1.2 of the Annex to Community Directive 76/114/EEC, or
 - (ii) in any case, in sections 3 and 4 of the Annex to Community Directive 78/507/EEC;
 - (b) the name of the manufacturer; and
 - (c) the approval reference number of either –
 - (i) the type approval certificate which relates to the vehicle model or the model variant of the vehicle model, as the case may be, issued in accordance with the provisions of regulation 9(1) of, and Part 1 of Schedule 3 to, the Type Approval (Great Britain) Regulations, or

- (ii) the Minister's approval certificate which relates to the vehicle, issued in accordance with the provisions of regulation 9(2) of, and Part 1A of Schedule 4 to, the said Regulations:

Provided that the information required under sub-paragraph (c) may be shown clearly and indelibly on an additional plate which is fitted in a conspicuous and readily accessible position and which is affixed to a vehicle part which is not normally subject to replacement.

- (3) The vehicle identification number of every vehicle to which this Article applies shall be marked on the chassis, frame or other similar structure, on the offside of the vehicle, in a clearly visible and accessible position, and by a method such as hammering or stamping, in such a way that it cannot be obliterated or deteriorate.

75 Plates – agricultural trailed appliances

- (1) Save as provided in paragraph (3), every wheeled agricultural trailed appliance manufactured on or after 1st January 1986 shall be equipped with a plate affixed to the vehicle in a conspicuous and readily accessible position and which is clearly and indelibly marked with the particulars specified in paragraph (2).
- (2) Those particulars are –
 - (a) the name of the manufacturer of the appliance;
 - (b) the year in which the appliance was manufactured;
 - (c) the maximum gross weight;
 - (d) the unladen weight; and
 - (e) the maximum load which would be imposed by the appliance on the drawing vehicle.
- (3) In the case of a towed roller consisting of several separate rollers used in combination, a single plate shall satisfy the requirement specified in paragraph (2).

76 Plates – motor cycles and mopeds

- (1) This Article applies to every motor cycle and moped first used on or after 1st January 1982 which is not –
 - (a) propelled by an internal combustion engine with a cylinder capacity exceeding 125 cc;
 - (b) a mowing machine; or
 - (c) a pedestrian-controlled vehicle.
- (2) Every vehicle to which this Article applies shall be equipped with a plate which is securely affixed to the vehicle in a conspicuous and readily accessible position and which complies with the requirements of Schedule 11.

77 Department plates

- (1) Every goods vehicle and trailer manufactured on or after 1st January 1973 which has a maximum authorized mass exceeding 3,500 kgs shall, from the date of its registration under the 1993 Law, display in a visible position on the nearside of the

vehicle a plate displaying the particulars required by Schedule 12 in letters and figures of the dimensions and colour and on a background of the dimensions and colour contained in that Schedule.

78 Marking of weights on certain vehicles

- (1) This Article applies to a vehicle (other than an agricultural motor vehicle which is either a track-laying vehicle not exceeding 3050 kg in unladen weight or a wheeled vehicle which is –
 - (a) a locomotive;
 - (b) a motor tractor;
 - (c) a bus which is registered under the 1993 Law²⁰ (or any enactment repealed thereby); or
 - (d) an unbraked wheeled trailer, other than one mentioned in Article 16(3)(b)(i), (iii) or (iv) or (c) to (g).
- (2) There shall be plainly marked in a conspicuous place on the outside of a vehicle to which this Article applies, on its near side –
 - (a) if it is a vehicle falling in paragraph (1)(a), (b) or (c), its unladen weight; and
 - (b) if it is a vehicle falling in paragraph (1)(d), its maximum gross weight.

79 Additional markings

- (1) This Article applies to every goods vehicle to which Article 77 applies and for which a Department Plate is required.
- (2) Without prejudice to Article 77, any weight which by virtue of Article 86 may not be exceeded in the case of a goods vehicle to which this Article applies may be marked on either side, or on both sides, of the vehicle.
- (3) Where at any time by virtue of any provision contained in Article 81, a goods vehicle to which this Article applies may not be used in excess of a weight which is less than the gross weight which may not be exceeded by that vehicle by virtue of Article 86, the first-mentioned weight may be marked on either side, or on both sides, of the vehicle.
- (4) Where at any time by virtue of any provision contained in Article 82 and 83 a goods vehicle to which this Article applies is drawing, or being drawn by, another vehicle and those vehicles may not be used together in excess of a laden weight applicable to those vehicles by virtue of any such provision, that weight may be marked on either side, or on both sides, of that goods vehicle.

80 Test date discs

- (1) Every test date disc which is issued, following the issue of a goods vehicle test certificate, in respect of a trailer to which the Plating and Testing Regulations apply and for which a plating certificate has been issued shall be carried on the trailer in a legible condition and in a conspicuous and readily accessible position in which it is clearly visible by daylight from the nearside of the road, from the date of its issue

until but not beyond the date of expiry of that test certificate or the date of issue of a further test certificate for that trailer, whichever date is the earlier.

- (2) In this Article “test date disc” means a plate issued by the Secretary of State for Transport for the United Kingdom for a goods vehicle, being a trailer, following the issue of a goods vehicle test certificate for that trailer under the Plating and Testing Regulations and containing the following particulars –
- (a) the identification mark allotted to that trailer and shown in that certificate;
 - (b) the date until which that certificate is valid; and
 - (c) the number of the vehicle testing station shown in that certificate.

PART 4

CONDITIONS RELATING TO USE

A – LADEN WEIGHT

81 Maximum permitted laden weight of a vehicle

- (1) Save as provided in paragraph (2), the laden weight of a vehicle of a class specified in an item in column 2 of the Table shall not exceed the maximum permitted laden weight specified in that item in column 3.
- (2) The maximum permitted laden weight of a vehicle first used before 1st June 1973 which falls in item 1 or 2 shall not be less than would be the case if the vehicle fell in item 10.

TABLE

(Article 81(1))

1	2	3
<i>Item</i>	<i>Class of vehicle</i>	<i>Maximum permitted laden weight (kg)</i>
1	A wheeled heavy motor car or motor car which is not described in items 2, 3, 5 or 6 and which complies with the relevant braking requirement (see Article 84(3) to (6) in relation to buses)	The weight determined in accordance with Part 1 of Schedule 13
2	A wheeled heavy motor car or motor car which is not described in item 3, 5 or 6, which complies with the relevant braking requirement and in which – (a) every driving axle not being a steering axle is fitted with twin tyres; and (b) either every driving axle is fitted with road-friendly suspension or no axle has an axle weight exceeding 9,500 kg	The weight determined in accordance with Part 2 of Schedule 13
3	A wheeled heavy motor car or motor car (not	The weight specified in

1	2	3
<i>Item</i>	<i>Class of vehicle</i>	<i>Maximum permitted laden weight (kg)</i>
	being an agricultural motor vehicle) which forms part of an articulated vehicle and which complies with the relevant braking requirement	column (5) in Part 3 of Schedule 13 in the item which is appropriate having regard to columns (2), (3) and (4) in that Part
4	A wheeled trailer, including a composite trailer, but not including a semi-trailer which is drawn by a motor tractor, heavy motor car or motor car which complies with the relevant braking requirement other than a trailer described in items 7, 8, 9 or 12	As for item 1
5	An articulated bus (see Article 84(3) to (5))	27,000
6	A wheeled agricultural motor vehicle	As for item 1, but subject to a maximum of 24,390
7	A balanced agricultural trailer, as defined in paragraph (4) which is not described in items 9, 12 or 17	As for item 1, but subject to a maximum of 18,290
8	An unbalanced agricultural trailer, as defined in paragraph (4), which is not described in items 9, 12 or 17	18,290 inclusive of the weight imposed by the trailer on the drawing vehicle
9	A wheeled trailer manufactured on or after 27th February 1977 and fitted with brakes which automatically come into operation on the overrun of the trailer (whether or not it is fitted with any other brake), except an agricultural trailer which is being drawn by an agricultural motor vehicle, which complies with the requirements specified in items 3, 14 and 17 of Schedule 2 and of which the brakes can be applied either by the driver of the drawing vehicle or by some other person on that vehicle or on the trailer	3,500
10	A wheeled heavy motor car or motor car not described in item 1, 3, 5 or 6 – (a) with not more than 4 wheels; (b) with more than 4 but not more than 6 wheels; (c) with more than 6 wheels	14,230 20,330 24,390
11	A wheeled trailer not described in item 4, 7, 8, 9 or 12 having less than 6 wheels, and not forming part of an articulated vehicle; and an agricultural trailed appliance	14,230
12	A trailer manufactured before 27th February 1977 and having no brakes other than – (a) a parking brake; and (b) brakes which come into operation on the overrun of the trailer	3560

1	2	3
<i>Item</i>	<i>Class of vehicle</i>	<i>Maximum permitted laden weight (kg)</i>
13	A wheeled locomotive, not described in item 6, which is equipped with suitable and sufficient springs between each wheel and the vehicle's frame and with a pneumatic tyre or a tyre of soft or elastic material fitted to each wheel – (a) if having less than 6 wheels; (b) if having 6 wheels; (c) if having more than 6 wheels	22,360 25,420 30,490
14	A track-laying locomotive with resilient material interposed between the rims of the weight-carrying rollers and the road so that the weight of the vehicle (other than that borne by any wheels and the portion of the track in contact with the road) is supported by the resilient material	22,360
15	A locomotive not described in item 6, 13 or 14	20,830
16	A track-laying heavy motor car or motor car	22,360
17	A track-laying trailer	12,210

- (3) The maximum total weight of all trailers, whether laden or unladen, drawn at any one time by a locomotive shall not exceed 40,650 kg.
- (4) In this Part of this Order and in Schedule 13 –
- “air spring” means a spring operated by means of air or other compressible fluid under pressure;
- “air suspension” means a suspension system in which at least 75% of the spring effect is caused by an air spring;
- “balanced agricultural trailer” means an agricultural trailer the whole of the weight of which is borne by its own wheels; and
- “unbalanced agricultural trailer” means an agricultural trailer of which some, but not more than 35%, of the weight is borne by the drawing vehicle and the rest of the weight is borne by its own wheels.
- (5) For the purposes of this Part and Schedule 13, an axle shall be regarded as fitted with a road-friendly suspension if its suspension is –
- (a) an air suspension; or
- (b) a suspension, not being an air suspension, which is regarded as being equivalent to an air suspension for the purposes of Community Directive 92/7.
- (6) For the purposes of this Part and Schedule 13, an axle shall be regarded as fitted with twin tyres if it would be regarded as fitted with twin tyres for the purposes of Community Directive 92/7.

82 Maximum permitted laden weight of a vehicle and trailer, other than an articulated vehicle

- (1) The total laden weight of a motor vehicle and the trailer or trailers (other than semi-trailers) drawn by it shall not, in a case specified in an item in column 2 of the Table, exceed the maximum permitted train weight specified in that item in column 3.
- (2) In this Article, the expressions “road-friendly suspension”, “twin tyres” and “unbalanced agricultural trailer” shall be construed in accordance with Article 81(4), (5) and (6).

TABLE
(Article 82(1))

1	2	3
<i>Item</i>	<i>Class of vehicle</i>	<i>Maximum permitted laden weight (kg)</i>
1	A wheeled trailer which is drawn by a wheeled motor tractor, heavy motor car or motor car (not being in any case an agricultural motor vehicle), where – (a) the combination has a total of 4 axles and is being used for international transport; and (b) the drawing vehicle is a vehicle which was first used on or after 1st April 1973 and complies with the relevant braking requirement	35,000
2	A wheeled trailer which is drawn by a wheeled motor tractor, heavy motor car or motor car (not being in any case an agricultural motor vehicle) where the combination has a total of 4 axles and the following conditions are satisfied in relation to the drawing vehicle, namely – (a) it was first used on or after 1st April 1973; (b) it complies with the relevant braking requirement; (c) every driving axle not being a steering axle is fitted with twin tyres; and (d) every driving axle is fitted with road-friendly suspension	35,000
3	A wheeled trailer which is drawn by a wheeled motor tractor, heavy motor car or motor car (not being in any case an agricultural motor vehicle) where the combination has a total of 5 or more axles and the following conditions are satisfied in relation to the drawing vehicle, namely – (a) it was first used on or after 1st April 1973; (b) it complies with the relevant braking requirement; (c) every driving axle not being a steering axle is fitted with twin tyres; and	38,000

1	2	3
<i>Item</i>	<i>Class of vehicle</i>	<i>Maximum permitted laden weight (kg)</i>
	(d) either every driving axle is fitted with road-friendly suspension or no axle has an axle weight exceeding 8,500 kg	
4	A wheeled trailer, not being part of a combination described in item 1, 2 or 3 which is drawn by a wheeled motor tractor, heavy motor car or motor car (not being in any case an agricultural motor vehicle) where – (a) the trailer is fitted with power-assisted brakes which can be operated by the driver of the drawing vehicle and are not rendered ineffective by the non-rotation of its engine; and (b) the drawing vehicle is equipped with a warning device so placed as to be readily visible to the driver of the vehicle and which is capable of indicating any impending failure of, or deficiency in, the vacuum or pressure system	32,520
5	A wheeled trailer which is of a description specified in item 9 in the Table of Article 81 drawn by a wheeled motor tractor, heavy motor car or motor car (not being in any case an agricultural motor vehicle) the drawing vehicle being a vehicle which – (a) was first used on or after 1st April 1973; and (b) complies with the relevant braking requirement	29,500
6	A wheeled agricultural motor vehicle drawing a wheeled unbalanced agricultural trailer, if the distance between the rearmost axle of the trailer and the rearmost axle of the drawing vehicle does not exceed 2.9 m	20,000
7	A wheeled trailer or trailers drawn by a wheeled heavy tractor, heavy motor car, motor car or agricultural motor vehicle, not being a combination of vehicles mentioned in items 1 to 6	24,390
8	A track-laying trailer drawn by a motor tractor, heavy motor car or motor car, whether wheeled or track-laying and a wheeled trailer, drawn by a track-laying vehicle being a motor tractor, heavy motor car or motor car	22,360

83 Maximum permitted laden weight of an articulated vehicle

- (1) Except as provided in paragraph (2), the laden weight of an articulated vehicle of a class specified in an item in column 2 of the Table shall not exceed the weight specified in column 3 in that item.

TABLE
(Article 83(1))

1	2	3
<i>Item</i>	<i>Class of vehicle</i>	<i>Maximum permitted laden weight (kg)</i>
1	An articulated vehicle which complies with the relevant braking requirement	Whichever is the lower of – (a) the weight specified in column (3) of Part 4 of Schedule 13 in the item in which the spacing between the rearmost axles of the motor vehicle and the semi-trailer is specified in column (2); (b) if the vehicle is of a description specified in an item in column (2) of Part 5 of Schedule 13, the weight specified in column (3) of that item
2	An articulated vehicle which does not comply with the relevant braking requirement if the trailer has – (a) less than 4 wheels; (b) 4 wheels or more	20,330 24,390

- (2) This Article does not apply to an agricultural motor vehicle, an agricultural trailer or an agricultural trailed appliance.
- (3) In Part 5 of Schedule 13, “road-friendly suspension” and “twin tyres” shall be construed in accordance with Article 81(5) and (6).

84 Maximum permitted wheel and axle weights

- (1) The weight transmitted to the road by one or more wheels of a vehicle as mentioned in an item in column 2 of the Table shall not exceed the maximum permitted weight specified in that item in column 3.
- (2) The Parts of the Table have the following application –
- (a) Part 1 applies to wheeled heavy motor cars, motor cars and trailers which comply with the relevant braking requirement and to wheeled agricultural motor vehicles, agricultural trailers and agricultural trailed appliances; items 1(b) and (2) also apply to buses; and
- (b) Part 2 applies to track-laying vehicles.

TABLE
(Article 84(1))

PART 1

(wheeled heavy motor cars, motor cars and trailers which comply with the relevant braking requirement and wheeled agricultural motor vehicles, agricultural trailers and agricultural trailed appliances; and, in respect of items 1(b) and 2, buses)

1	2	3
<i>Item</i>	<i>Class of vehicle</i>	<i>Maximum permitted laden weight (kg)</i>
1	Two wheels in line transversely each of which is fitted with a wide tyre or with 2 pneumatic tyres having the centres of their areas of contact with the road not less than 300 mm apart, measured at right angles to the longitudinal axis of the vehicle – (a) if the wheels are on the sole driving axle of a motor vehicle (not being a bus); (b) if the vehicle is a bus which has 2 axles of which the weight transmitted to the road surface by its wheels is calculated in accordance with Article 84(5); (c) in any other case	10,500 10,500 10,170
2	Two wheels in line transversely otherwise than as mentioned in item 1	9200
3	More than 2 wheels in line transversely – (a) in the case of a vehicle manufactured before 1st May 1983 where the wheels are on one axle of a group of closely spaced axles; (b) in the case of a vehicle manufactured on or after 1st May 1983; (c) in any other case	10,170 10,170 11,180
4	One wheel not transversely in line with any other wheel – (a) if the wheel is fitted as described in item 1; (b) in any other case	5090 4600

PART 2

(track-laying vehicles)

1	2	3
<i>Item</i>	<i>Wheel criteria</i>	<i>Maximum permitted laden weight (kg)</i>
5	The weight of a heavy motor car, motor car or trailer transmitted to any strip of the road surface on which the vehicle rests contained between 2 parallel lines 0.6 m apart at right angles to the longitudinal axis of the vehicle	10,170
6	Two wheels in line – (a) heavy motor cars or motor cars with 2 wheels; (b) heavy motor cars or motor cars with more than 2 wheels	8130 7630
7	One wheel, where no other wheel is in the same line transversely, on a heavy motor car or a motor car	4070

- (3) In the case of an articulated bus, or, subject to paragraph (4), of a bus first used before 1st April 1988, the laden weight, for the purposes of Article 81, and the weight transmitted to the road surface by wheels of the vehicle, for the purposes of

items 1 and 2 of the Table shall be calculated with reference to the vehicle when it is complete and fully equipped for service with –

- (a) a full supply of water, oil and fuel; and
 - (b) weights of 63.5 kg for each person (including crew) –
 - (i) for whom a seat is provided in the position in which the person may be seated, and
 - (ii) who may by or under any enactment be carried standing, the total of such weights being reasonably distributed in the space in which such persons may be carried, save that in the case of a bus (not being an articulated bus) only the number of such persons exceeding 8 shall be taken into account.
- (4) The weights for the purposes referred to in paragraph (3) may, in the case of a bus to which that paragraph applies, be calculated in accordance with paragraph (5) instead of paragraph (3).
- (5) In the case of a bus first used on or after 1st April 1988, the weights for the purposes referred to in paragraph (3) shall be calculated with reference to the vehicle when it is complete and fully equipped for service with –
- (a) a full supply of water, oil and fuel;
 - (b) a weight of 65 kg for each person (including crew) –
 - (i) for whom a seat is provided, in the position in which the person may be seated, and
 - (ii) who may pursuant to any provision in the 1935 Law be carried standing, the total of such weights being reasonably distributed in the space in which such persons may be so carried, save that in the case of a bus (not being an articulated bus) only the number of such persons exceeding 4 shall be taken into account;
 - (c) all luggage space within the vehicle but not within the passenger compartment loaded at the rate of 100 kg per m³ or 10 kg per person mentioned in sub-paragraph (b), whichever is the less; and
 - (d) any area of the roof of the vehicle constructed or adapted for the storage of luggage loaded with a uniformly distributed load at the rate of 75 kg per m².
- (6) Article 81 shall not apply to a 2-axle bus if –
- (a) its laden weight as calculated in accordance with paragraph (5) does not exceed 17,000 kg; and
 - (b) the distance between the 2 axles is at least 3.0 m.

85 Maximum permitted weights for certain closely-spaced axles etc.

- (1) This Article applies to –
- (a) a wheeled motor vehicle which complies with the relevant braking requirement;
 - (b) a wheeled trailer which is drawn by such a motor vehicle; and

- (c) an agricultural motor vehicle, an agricultural trailer and an agricultural trailed appliance.
- (2) Save as provided in paragraph (5), where a vehicle to which this Article applies is of a description specified in an item in column 2 of Part 6 of Schedule 13 and has 2 closely-spaced axles, the total weight transmitted to the road surface by all the wheels of those axles shall not exceed the maximum permitted weight specified in column 3 of that item.
- (3) Save as provided in paragraph (5), where a vehicle to which this Article applies is of a description specified in an item in column 2 of Part 7 of Schedule 13 and has 3 closely-spaced axles, the total weight transmitted to the road surface by all the wheels of those axles shall not exceed the weight specified in column 3.
- (4) Save as provided by paragraph (5), where a vehicle is fitted with 4 or more closely-spaced axles, the weight transmitted to the road surface by all the wheels of those axles shall not exceed 24,000 kg.
- (5) Nothing in paragraph (2), (3) or (4) shall apply so as to prevent a vehicle first used before 1st June 1973 from being used on a road at a weight as respects those axles at which it could be used if it fell within item 5 in the Table in Article 84.
- (6) In Parts 6 and 7 of Schedule 13, “air-suspension”, “road-friendly suspension” and “twin tyres” shall be construed in accordance with Article 81(4), (5) and (6).

86 Over-riding weight restrictions

- (1) Subject to paragraph (2), no person shall use, or cause or permit to be used, on a road a vehicle –
 - (a) fitted with a plate in accordance with Article 73 if any of the weights shown on the plate is exceeded;
 - (b) required by Article 75 to be fitted with a plate, if the maximum gross weight referred to in (2)(c) of that Article is exceeded.
- (2) Where any 2 or more axles are fitted with a compensating arrangement in accordance with Article 23 the sum of the axle weights shall not be exceeded. The sum of the weights referred to shall be that shown for the said axles in the plate fitted in accordance with Article 73.
- (3) Nothing in Articles 81 to 85 shall permit any such weight as is mentioned in this Article to be exceeded and nothing in this Article shall permit any weight prescribed by Articles 81 to 85 in relation to the vehicle in question to be exceeded.

B – DIMENSIONS OF LADEN VEHICLES

87 Interpretation for the purposes of Articles 87, 88 and Schedule 14

For the purposes of this Article, Article 88 and Schedule 14 –

- (a) “lateral projection” in relation to a load carried by a vehicle, means that part of the load which extends beyond a side of the vehicle;
- (b) the width of any lateral projection shall be measured between longitudinal planes passing through the extreme projecting point of the vehicle on that

side on which the projection lies and that part of the projection furthest from that point;

- (c) references to a special appliance or apparatus, in relation to a vehicle, are references to any crane or other special appliance or apparatus fitted to the vehicle which is a permanent or essentially permanent fixture;
- (d) “forward projection” and “rearward projection” –
 - (i) in relation to a load carried in such a manner that its weight is borne by only one vehicle, mean respectively that part of the load which extends beyond the foremost point of the vehicle and that part which extends beyond the rearmost point of the vehicle,
 - (ii) in relation to a load carried in such a manner that part of its weight is borne by more than one vehicle, mean respectively that part of the load which extends beyond the foremost point of the foremost vehicle by which the load is carried, except where the context otherwise requires, and that part of the load which extends beyond the rearmost point of the rearmost vehicle by which the load is carried, and
 - (iii) in relation to any special appliance or apparatus, mean respectively that part of the appliance or apparatus which, if it were deemed to be a load carried by the vehicle, would be a part of a load extending beyond the foremost point of the vehicle and that part which would be a part of a load extending beyond the rearmost point of the vehicle,

and references in Article 88 and Schedule 14 to a forward projection or to a rearward projection in relation to a vehicle shall be construed accordingly;

- (e) the length of any forward projection or of any rearward projection shall be measured between transverse planes passing –
 - (i) in the case of a forward projection, through the foremost point of the vehicle and that part of the projection furthest from that point, and
 - (ii) in the case of a rearward projection, through the rearmost point of the vehicle and that part of the projection furthest from that point.

In this sub-paragraph and in sub-paragraph (d) “vehicle” does not include any special appliance or apparatus or any part thereof which is a forward projection or a rearward projection;

- (f) references to the distance between vehicles, in relation to vehicles carrying a load, are references to the distance between the nearest points of any 2 adjacent vehicles by which the load is carried, measured when the longitudinal axis of each vehicle lies in the same vertical plane.

For the purposes of this sub-paragraph, in determining the nearest point of 2 vehicles any part of either vehicle designed primarily for use as a means of attaching the one vehicle to the other and any fitting designed for use in connection with any such part shall be disregarded;

- (g) references to a combination of vehicles, in relation to a motor vehicle which is drawing one or more trailers, are references to the motor vehicle and the trailer or trailers drawn thereby, including any other motor vehicle which is used for the purpose of assisting in the propulsion of the trailer or trailers on the road;

- (h) the overall length of a combination of vehicles shall be taken as the distance between the foremost point of the drawing vehicle comprised in the combination and the rearmost point of the rearmost vehicle comprised therein, measured when the longitudinal axis of each vehicle comprised in the combination lies in the same vertical plane;
- (i) the extreme projecting point of a vehicle is the point from which the overall width of the vehicle is calculated in accordance with the definition of overall width contained in Article 1(1);
- (j) without prejudice to sub-paragraph (e) the foremost or, as the case may be, the rearmost point of a vehicle is the foremost and rearmost point from which the overall length of the vehicle is calculated in accordance with the definition of overall length contained in Article 1(1); and
- (k) an agricultural, horticultural or forestry implement rigidly but not permanently mounted on an agricultural motor vehicle, agricultural trailer or agricultural trailed appliance, whether or not part of its weight is supported by one or more of its own wheels, shall not be treated as a load, or special appliance, on that vehicle.

88 Restrictions on use of vehicles carrying wide or long loads or having fixed appliances or apparatus

- (1) No load shall be carried on a vehicle so that the overall width of the vehicle together with the width of any lateral projection or projections of its load exceeds 2.9 m.
- (2) Subject to this Article, no load shall be carried on a vehicle so that –
 - (a) the load has a lateral projection or projections on either side exceeding 305 mm; or
 - (b) the overall width of the vehicle and of any lateral projection or projections of its load exceeds 2.9 m:

Provided that this paragraph does not apply to the carriage of –

- (i) loose agricultural produce not baled or crated, or
 - (ii) an indivisible load –
 - (A) if it is not reasonably practicable to comply with this paragraph and the conditions specified in paragraphs 1 and 5 of Schedule 14 are complied with, and
 - (B) where the overall width of the vehicle together with the width of any lateral projection or projections of its load exceeds 2.9 m, a licence pursuant to Article 78 of the Law is in force in respect of it and the conditions specified in paragraph 2 of Schedule 14 are complied with.
- (3) Where a load is carried so that its weight rests on a vehicle or vehicles, the length specified in paragraph (5) shall not exceed 16.5 m.
 - (4) A load shall not be carried so that its weight is borne by a vehicle or vehicles if either –
 - (a) the length specified in paragraph (5) exceeds 16.5 m; or

(b) the load is borne by a trailer or trailers and the length specified in paragraph (6) exceeds 16.5 m,

unless a licence pursuant to Article 78 of the Law is in force in respect of it and the conditions specified in paragraphs 1 and 2 of Part 1 of Schedule 14 are complied with.

- (5) The length referred to in paragraphs (3) and paragraph (4)(a) is –
- (a) where the weight of the load is borne by a single vehicle, the overall length of the vehicle together with the length of any forward and rearward projection of the load;
- (b) where the weight of the load is borne by a motor vehicle and one trailer, whether or not forming an articulated vehicle, the overall length of the trailer together with the length of any projection of the load in front of the foremost point of the trailer and of any rearward projection of the load; and
- (c) in any other case, the overall length of all the vehicles which bear the weight of the load together with the length of any distance between them and of any forward or rearward projection of the load.
- (6) The length referred to in paragraph (4)(b) is the overall length of the combination of vehicles, together with the length of any forward or rearward projection of the load.
- (7) Subject to this Article no person shall use, or cause or permit to be used, on a road a vehicle, not being a straddle carrier, carrying a load or fitted with a special appliance or apparatus if the load, appliance or apparatus has a forward projection of a length specified in an item in column 2 of the Table, or rearward projection of a length specified in an item in column 3, unless a licence pursuant to Article 78 of the Law is in force in respect of it and the conditions specified in that item in column 4 are complied with.

TABLE

(Article 88(7))

1	2	3	4
<i>Item</i>	<i>Length of forward projection</i>	<i>Length of rearward projection</i>	<i>Conditions to be complied with</i>
1	Exceeding 1 m but not exceeding 2 m	–	Paragraph 4 of Schedule 14
2	Exceeding 2 m but not exceeding 3.05 m	–	Paragraphs 2 and 3 of Schedule 14
3	Exceeding 3.05 m	–	Paragraphs 1, 2 and 3 of Schedule 14
4	–	Exceeding 1 m but not exceeding 2 m	Paragraph 4 of Schedule 14
5	–	Exceeding 2 m but not exceeding 3.05 m	Paragraph 3 of Schedule 14
6	–	Exceeding 3.05 m	Paragraphs 1, 2 and 3 of Schedule 14

- (8) Subject to this Article, no person shall use, or cause or permit to be used, on a road a straddle carrier carrying a load if –
- (a) the load has a rearward projection exceeding 1 m unless the conditions specified in paragraph 4 of Schedule 14 are met;
 - (b) the load has a forward projection exceeding 2 m or a rearward projection exceeding 3 m; or
 - (c) the overall length of the vehicle together with the length of any forward projection of its load exceeds 12.2 m:

Provided that –

- (i) sub-paragraph (a) does not apply to a vehicle being used in passing from one part of private premises to another part thereof or to other private premises in the immediate neighbourhood,
 - (ii) sub-paragraphs (b) and (c) do not apply to a vehicle being used as in clause (i) of this proviso if –
 - (A) the vehicle is not being driven at a speed exceeding 12 mph, and
 - (B) where the overall length of the vehicle together with the length of any forward projection and of any rearward projection of its load exceeds 12.2 m, the conditions specified in paragraphs 1 and 2 of Schedule 14 are complied with.
- (9) Where another vehicle is attached to that end of a vehicle from which a projection extends, then for the purposes of any requirement in this Article to comply with paragraph 3 or 4 of Schedule 14, that projection shall be treated as a forward or rearward projection only if, and to the extent that it extends beyond the foremost point or, as the case may be, the rearmost point of that other vehicle, measured when the longitudinal axis of each vehicle lies in the same vertical plane.
- (10) In the case of a vehicle being used –
- (a) for fire brigade, ambulance or police purposes or for defence purposes (including civil emergency purposes); or
 - (b) in connection with the removal of any obstruction to traffic,
- if compliance with any provision of this Article would hinder or be likely to hinder the use of the vehicle for the purpose for which it is being used, that provision does not apply to that vehicle while it is being so used.
- (11) No person shall use, or cause or permit to be used, on a road an agricultural, horticultural or forestry implement rigidly, but not permanently, mounted on a wheeled agricultural motor vehicle, agricultural trailed appliance, whether or not part of its weight is supported by one or more of its own wheels if –
- (a) the overall width of the vehicle together with the lateral projection of the implement exceeds 2.5 m; or
 - (b) the implement projects more than 1 m forwards or rearwards of the vehicle, so however, that this restriction shall not apply in a case where –
 - (i) part of the weight of the implement is supported by one or more of its own wheels; and

- (ii) the longitudinal axis of the greater part of the implement is capable of articulating in the horizontal plane in relation to the longitudinal axis of the rear portion of the vehicle.

C – TRAILERS AND SIDECAR

89 Number of trailers

- (1) No person shall use, or cause or permit to be used, on a road a wheeled vehicle of a class specified in an item in column 2 of the Table drawing a trailer, subject to any exceptions which may be specified in that item in column 3.

TABLE

(Article 89(1))

1	2	3
<i>Item</i>	<i>Class of vehicle</i>	<i>Exceptions</i>
1	A straddle carrier	–
2	An invalid carriage	–
3	An articulated bus	–
4	A bus not being an articulated bus or a minibus	1 broken-down bus where no person other than the driver is carried in either vehicle
5	A locomotive	1 trailer
6	A motor tractor not being a road train as defined in the 1935 Law	1 trailer
7	A heavy motor car or a motor car not described in items 1, 3 and 4	2 trailers if one of them is a towing implement and part of the other is secured to and either rests on or is suspended from that implement; 1 trailer in any other case
8	An agricultural motor vehicle	(a) in respect of trailers other than agricultural trailers and agricultural trailed appliances such trailers as are permitted under item 5, 6 or 7 of this Table as the case may be; or (b) in respect of agricultural trailers and agricultural trailed appliances – (i) 1 agricultural trailer; or (ii) 1 agricultural trailed appliance

- (2) For the purpose of items 5, 6 and 7 of the Table –
- (a) an unladen articulated vehicle, when being drawn by another motor vehicle because it has broken down, shall be treated as a single trailer; and
- (b) a towed roller used for the purposes of agriculture, horticulture or forestry and consisting of several separate rollers shall be treated as one agricultural trailed appliance.

- (3) No track-laying motor vehicle which extends 8 m in overall length shall draw a trailer other than a broken-down vehicle which is being drawn in consequence of the breakdown.
- (4) For the purpose of this Article “trailer” does not include a vehicle which is drawn by a steam-powered vehicle and which is used solely for carrying water for the purpose of the drawing vehicle.

90 Trailers drawn by motor cycles

- (1) Save as provided in paragraph (2), no person shall use, or cause or permit to be used, on a road a motor cycle –
 - (a) drawing behind it more than one trailer;
 - (b) drawing behind it any trailer carrying a passenger;
 - (c) drawing behind it a trailer with an unladen weight exceeding 254 kg;
 - (d) which is a light motor cycle or moped, drawing behind it any trailer; or
 - (e) which is a heavy motor cycle, drawing behind it any trailer unless –
 - (i) the trailer has an overall width not exceeding 1 m,
 - (ii) the distance between the rear axle of the motor cycle and the rearmost part of the trailer does not exceed 2.5 m,
 - (iii) the motor cycle is clearly and indelibly marked in a conspicuous and readily accessible position with its kerbside weight,
 - (iv) the trailer is clearly and indelibly marked in a conspicuous and readily accessible position with its unladen weight, and
 - (v) the laden weight of the trailer does not exceed 150 kg or 2/3 of the kerbside weight of the motor cycle, whichever is the less.
- (2) The provisions in paragraph (1)(b), (d) and (e) do not apply if the trailer is a broken-down motor cycle and one passenger is riding it.

91 Trailers drawn by agricultural motor vehicles

- (1) No person shall use, or cause or permit to be used, on a road a wheeled agricultural motor vehicle drawing a wheeled trailer if the weight of the drawing vehicle is less than a quarter of the weight of the trailer, unless the brakes fitted to the trailer in compliance with Article 15 or 16 are operated directly by the service braking system fitted to the motor vehicle.
- (2) No person shall use, or cause or permit to be used, on a road any motor vehicle drawing an agricultural trailer by which –
 - (a) more than 35% of the weight is borne by the drawing vehicle; or
 - (b) the gross weight exceeds 14,230 kg, unless it is fitted with brakes as mentioned in paragraph (1).
- (3) No person shall use, or cause or permit to be used, on a road an agricultural trailer manufactured on or after 1st December 1985 which is drawn by a motor vehicle first used on or after 1st June 1986 unless the brakes fitted to the trailer –

- (a) in accordance with Article 15 can be applied progressively by the driver of the drawing vehicle, from the person's normal driving position and while keeping proper control of that vehicle, using a means of operation mounted on the drawing vehicle; or
- (b) automatically come into operation on the over-run of the trailer.

92 Distance between motor vehicles and trailers

- (1) Where a trailer is attached to the vehicle immediately in front of it solely by means of a rope or chain, the distance between the trailer and that vehicle shall not in any case exceed 4.5 m, and shall not exceed 1.5 m unless the rope or chain is made clearly visible to any other person using the road within a reasonable distance from either side.
- (2) For the purpose of determining the said distance any part of either vehicle designed primarily for use as a means of attaching the one vehicle to the other and any fitting designed for use in connection with any such part shall be disregarded.

93 Use of secondary coupling on trailers

- (1) No person shall use or cause or permit to be used on a road a motor vehicle drawing one trailer if the trailer –
 - (a) is a trailer to which Article 15 applies; and
 - (b) is not fitted with a device which is designed to stop the trailer automatically in the event of the separation of the main coupling while the trailer is in motion,unless the requirements of paragraph (2) are met in relation to the motor vehicle and trailer.
- (2) The requirements of this paragraph, in relation to a motor vehicle drawing a trailer, are that a secondary coupling is attached to the motor vehicle and trailer in such a way that, in the event of the separation of the main coupling while the trailer is in motion –
 - (a) the drawbar of the trailer would be prevented from touching the ground; and
 - (b) there would be some residual steering of the trailer.
- (3) No person shall use or cause or permit to be used on a road a motor vehicle drawing one trailer if –
 - (a) the trailer is a trailer to which Article 15 applies;
 - (b) the trailer is fitted with a device which is designed to stop the trailer automatically in the event of the separation of the main coupling while the trailer is in motion;
 - (c) the operation of the device in those circumstances depends upon a secondary coupling linking the device to the motor vehicle; and
 - (d) the trailer is not also fitted with a device which is designed to stop the trailer automatically in those circumstances in the absence of such a secondary coupling,

unless the requirements of paragraph (4) are met in relation to the motor vehicle and trailer.

- (4) The requirements of this paragraph, in relation to a motor vehicle drawing a trailer, are that the secondary coupling is attached to the motor vehicle and trailer in such a way that, in the event of the separation of the main coupling while the trailer is in motion, the device of the kind referred to in paragraph (3)(b) and (c) fitted to the trailer would stop the trailer.
- (5) This Article is without prejudice to any other provision in this Order.

94 Unbraked trailers

- (1) Save as provided in paragraph (2), no person shall use, or cause or permit to be used, on a road an unbraked wheeled trailer if –
 - (a) its laden weight exceeds its maximum gross weight; or
 - (b) it is drawn by a vehicle of which the kerbside weight is less than twice the sum of the unladen weight of the trailer and the weight of any load which the trailer is carrying.
- (2) This Article does not apply to –
 - (a) an agricultural trailer; or
 - (b) a trailer mentioned in Article 16(3)(b) (excluding clause (ii)) to (g).

95 Use of bridging plates between motor vehicle and trailer

- (1) Save as provided in paragraph (2), no person shall use or cause or permit to be used, on a road a motor vehicle constructed for the purpose of carrying other vehicles or any trailer constructed for that purpose so that while such vehicle or trailer is on a road any part of the weight of any vehicle which is being carried rests on a plate of a kind mentioned in the definition in Article 1(1)(a)(viii) of “overall length”.
- (2) The provisions of paragraph (1) do not apply –
 - (a) while the motor vehicle or trailer constructed for the purpose of carrying other vehicles is being loaded or unloaded; or
 - (b) if the plate is folded or withdrawn so that it does not bridge the gap between the motor vehicle and the trailer.

96 Leaving trailers at rest

No person in charge of a motor vehicle, or trailer drawn thereby, shall cause or permit such trailer to stand on a road when detached from the drawing vehicle unless one at least of the wheels of the trailer is (or, in the case of a track-laying trailer, its tracks are) prevented from revolving by the setting of the brake or the use of a chain, chock or other efficient device.

97 Passengers in trailer

- (1) Save as provided in paragraph (2) and except in the case of a trailer forming part of a Public Services Vehicle licensed under the 1935 Law for use as a char-à-banc, no person shall use, or cause or permit to be used, on a road any trailer for the carriage of passengers for hire or reward.
- (2) The provisions of paragraph (1) do not apply in respect of a wheeled trailer which is, or is carrying, a broken-down motor vehicle if –
 - (a) the trailer is drawn at a speed not exceeding 30 mph; and
 - (b) where the trailer is, or is carrying, a broken-down bus, it is attached to the drawing vehicle by a rigid draw bar.
- (3) Save as provided in paragraph (4), no person shall use, or cause or permit to be used, on a road a wheeled trailer in which any person is carried and which is a living van having either –
 - (a) less than 4 wheels; or
 - (b) 4 wheels consisting of 2 close-coupled wheels on each side.
- (4) The provisions of paragraph (3) do not apply in respect of a trailer which is being tested by –
 - (a) its manufacturer;
 - (b) a person by whom it has been, or is being, repaired; or
 - (c) a distributor of, or dealer in, trailers.

98 Attachment of sidecars

Every sidecar fitted to a motor cycle shall be so attached that the wheel thereof is not wholly outside the space between transverse planes passing through the extreme projecting points at the front and at the rear of the motor cycle.

99 Use of sidecars

No person shall use or cause or permit to be used, on a road any 2-wheeled motor cycle, not being a motor cycle brought temporarily into Jersey by a person resident outside Jersey, if there is a sidecar attached to the right (or off) side of the motor cycle.

*D – USE OF GAS PROPULSION SYSTEMS AND GAS-FIRED APPLIANCES***100 Use of gas propulsion systems**

- (1) No person shall use, or cause or permit to be used, on a road a vehicle with a gas propulsion system unless the whole of such system is in a safe condition.
- (2) No person shall use, or cause or permit to be used, in any gas supply system for the propulsion of a vehicle when the vehicle is on a road any fuel except liquefied petroleum gas.
- (3) No person shall use, or cause or permit to be used, on a road a vehicle which is propelled by gas unless the gas container in which such fuel is stored is on the

motor vehicle, and not on any trailer, and in the case of an articulated vehicle on the portion of the vehicle to which the engine is fitted.

- (4) In this Article and in Article 102 “liquefied petroleum gas” means –
- (a) butane gas in any phase which meets the requirements contained in the specification of commercial butane and propane issued by the British Standards Institution under the number BS4250: 1975 and published on 29th August 1975;
 - (b) propane gas in any phase which meets the requirements contained in the said specification; or
 - (c) any mixture of such butane gas and such propane gas.

101 Use of gas-fired appliances – general

- (1) No person shall use, or cause or permit to be used, in or on a vehicle on a road any gas-fired appliance unless the whole of such appliance and the gas system attached thereto is in an efficient and safe condition.
- (2) No person shall use, or cause or permit to be used, in any gas-fired appliance in or on a vehicle on a road any fuel except liquefied petroleum gas as defined in Article 100(4).
- (3) No person shall use, or cause or permit to be used, in or on a vehicle on a road any gas-fired appliance unless the vehicle is so ventilated that –
 - (a) an ample supply of air is available for the operation of the appliance;
 - (b) the use of the appliance does not adversely affect the health or comfort of any person using the vehicle; and
 - (c) any unburnt gas is safely disposed of to the outside of the vehicle.
- (4) No person shall use, or cause or permit to be used, on a road a vehicle in or on which there is –
 - (a) one gas-fired appliance unless the gas supply for such appliance is shut off at the point where it leaves the container at all times when the appliance is not in use;
 - (b) more than one gas-fired appliance each of which has the same supply of gas unless the gas supply for such appliances is shut off at the point where it leaves the container or containers at all times when none of such appliances is in use; or
 - (c) more than one gas-fired appliance each of which does not have the same supply of gas unless each gas supply for such appliances is shut off at the point where it leaves the container or containers at all times when none of such appliances which it supplies is in use.

102 Use of gas-fired appliances when a vehicle is in motion

- (1) Subject to paragraph (2), this Article applies to every motor vehicle and trailer.
- (2) Paragraphs (3) and (4) do not apply to a vehicle constructed or adapted for the conveyance of goods under controlled temperatures.

- (3) No person shall use, or cause or permit to be used, in any vehicle to which this paragraph applies, while the vehicle is in motion on a road, any gas-fired appliance except –
- (a) a gas-fired appliance which is fitted to engineering plant while the plant is being used for the purposes of the engineering operations for which it was designed;
 - (b) a gas-fired appliance which is permanently attached to a bus, provided that any appliance for heating or cooling the interior of the bus for the comfort of the driver and any passengers does not expose a naked flame on the outside of the appliance; or
 - (c) in any other vehicle, a refrigerating appliance or an appliance which does not expose a naked flame on the outside of the appliance and which is permanently attached to the vehicle and designed for the purpose of heating any part of the interior of the vehicle for the comfort of the driver and any passengers.
- (4) No person shall use, or cause or permit to be used, in any vehicle to which this paragraph applies, while the vehicle is in motion on a road, any gas-fired appliance to which –
- (a) paragraph (3)(a) refers, unless the appliance complies with the requirements specified in paragraphs 12 and 13 of Schedule 5 and the gas system to which it is attached complies with the requirements specified in paragraphs 2 to 9 and 15 of Schedule 5;
 - (b) paragraph (3)(b) refers, unless the appliance complies with the requirements specified in paragraphs 12, 13 and 14 of Schedule 5 and the gas system to which it is attached complies with the requirements specified in paragraphs 2 to 9, 11 and 15 of Schedule 5; or
 - (c) paragraph (3)(c) refers, unless the appliance complies –
 - (i) if it is fitted to a motor vehicle, with the requirements specified in paragraphs 12, 13 and 14 of Schedule 5, and
 - (ii) in any other case, with the requirements specified in paragraphs 12 and 13 of Schedule 5,and the gas system to which the appliance is attached complies with the requirements specified in paragraphs 2 to 9 and 15 of Schedule 5.
- (5) No person shall use, or cause or permit to be used, in a vehicle to which this Article applies which is in motion on a road any gas-fired appliance unless it is fitted with a valve which stops the supply of gas to the appliance if the appliance fails to perform its function and causes gas to be emitted.

E – CONTROL OF NOISE

103 Avoidance of excessive noise

- (1) No motor vehicle shall be used on a road in such manner as to cause any excessive noise which could have been avoided by the exercise of reasonable care on the part of the driver.

- (2) In this Article “excessive noise” means a noise, measured with a sound level meter, emitted from the exhaust of a motor vehicle which is louder than the noise emitted from the exhaust of another motor vehicle of the same class, type and engine size and being used in similar conditions and which complies with Article 59(2).

104 Stopping of engine when stationary

- (1) Save as provided in paragraph (2), the driver of a vehicle shall, when the vehicle is stationary, stop the action of any machinery attached to or forming part of the vehicle so far as may be necessary for the prevention of noise.
- (2) The provisions in paragraph (1) do not apply –
- (a) when the vehicle is stationary owing to the necessities of traffic;
 - (b) so as to prevent the examination or working of the machinery where the examination is necessitated by any failure or derangement of the machinery or where the machinery is required to be worked for a purpose other than driving the vehicle; or
 - (c) in respect of a vehicle propelled by gas produced in plant carried on the vehicle, to such plant.

105 Use of audible warning instruments

- (1) Subject to this Article, no person shall sound, or cause or permit to be sounded, any horn, gong, bell or siren fitted to or carried on a vehicle which is –
- (a) stationary on a road, at any time, other than at times of danger due to another moving vehicle on or near the road; or
 - (b) in motion on any road, between 11 pm and 6 am in the following morning.
- (2) The provisions of paragraph (1)(a) do not apply in respect of the sounding of a reversing alarm when the vehicle to which it is fitted is about to move backwards and its engine is running.
- (3) No person shall sound, or cause or permit to be sounded, on a road any reversing alarm fitted to a vehicle –
- (a) unless the vehicle is a goods vehicle which has a maximum gross weight not less than 2,000 kg, a bus, an emergency vehicle, engineering plant, a refuse vehicle, or a works truck; or
 - (b) if the sound of the alarm is likely to be confused with a sound emitted in the operation of a pedestrian crossing established, or having effect as if established, under the Law.
- (4) Subject to paragraphs (5) and (6), no person shall sound, or cause or permit to be sounded a gong, bell, siren or 2-tone horn, fitted to or otherwise carried on a vehicle (whether it is stationary or not).
- (5) Nothing in paragraph (1) or (4) shall prevent the sounding of –
- (a) an instrument or apparatus fitted to, or otherwise carried on, a vehicle at a time when the vehicle is being used for one of the purposes specified in Article 37(5) and it is necessary or desirable to do so either to indicate to other road users the urgency of the purpose for which the vehicle is being

- used, or to warn other road users of the presence of the vehicle on the road;
or
- (b) a horn (not being a two-tone horn), bell, gong or siren –
 - (i) to raise alarm as to the theft or attempted theft of the vehicle or its contents, or
 - (ii) in the case of a bus, to summon help for the driver, the conductor or an inspector.
- (6) Notwithstanding paragraphs (1) and (4), a person may, between 12 midday and 7pm, sound or cause or permit to be sounded an instrument or apparatus, other than a 2-tone horn, fitted to or otherwise carried on a vehicle, being an instrument or apparatus designed to emit a sound for the purpose of informing members of the public that the vehicle is conveying goods for sale, if, when the apparatus or instrument is sounded, it is sounded only for that purpose.
- (7) For the purpose of this Article the expressions which are referred to in Article 37(10) have the meanings there given to them.

F – AVOIDANCE OF DANGER

106 Maintenance and use of vehicle so as not to be a danger, etc.

- (1) A motor vehicle, every trailer drawn thereby and all parts and accessories of such vehicle and trailer shall at all times be in such condition, and the number of passengers carried by such vehicle or trailer, the manner in which any passengers are carried in or on such vehicle or trailer, and the weight, distribution, packing and adjustment of the load of such vehicle or trailer shall at all times be such, that no danger is caused or is likely to be caused to any person in or on the vehicle or trailer or on a road:
- Provided that the provisions of this Article with regard to the number of passengers carried shall not apply to a vehicle to which the 1935 Law applies.
- (2) The load carried by a motor vehicle or trailer shall at all times be so secured, if necessary by physical restraint other than its own weight, and be in such a position, that neither danger nor nuisance is likely to be caused to any person or property by reason of the load or any part thereof falling or being blown from the vehicle or by reason of any other movement of the load or any part thereof in relation to the vehicle.
- (3) No motor vehicle or trailer shall be used for any purpose for which it is so unsuitable as to cause or be likely to cause danger or nuisance to any person in or on the vehicle or trailer or on a road.
- (4) No front device –
- (a) of the kind commonly known as “bull bars”; or
 - (b) of any similar nature, by whatever name the device is called,
- shall be carried by a motor vehicle, unless the device is non-metallic or flexible.

107 Restricted speed

- (1) No person shall use, or cause or permit to be used, on a road a vehicle displaying the rectangular plate described in the definition of “low platform trailer” in Article 1(1) or anything resembling such a plate at a speed exceeding 30 mph.
- (2) No person shall use, or cause or permit to be used on a road a vehicle displaying the rectangular plate described in Schedule 15 or anything resembling such a plate at a speed exceeding 30 mph.

108 Parking in darkness

- (1) Save as provided in paragraph (2), no person shall, except with the permission of a police officer, cause or permit any motor vehicle to stand on a road at any time between sunset and sunrise unless the near side of the vehicle is as close as may be to the edge of the carriageway.
- (2) Paragraph (1) does not apply in respect of any motor vehicle –
 - (a) being used for the fire brigade, ambulance or police purposes or for defence purposes (including civil emergency purposes) if compliance with those provisions would hinder or be likely to hinder the use of the vehicle for the purpose for which it is being used on that occasion;
 - (b) being used in connection with –
 - (i) any building operation or demolition,
 - (ii) the repair of any other vehicle,
 - (iii) the removal of any obstruction to traffic,
 - (iv) the maintenance, repair or reconstruction of any road, or
 - (v) the laying, erection, alteration or repair in or near to any road of any sewer, main, pipe or apparatus for the supply of gas, water or electricity, of any telecommunication apparatus or of the apparatus of any electric transport undertaking,if, in any such case, compliance with those provisions would hinder or be likely to hinder the use of the vehicle for the purpose for which it is being used on that occasion;
 - (c) on any road in which vehicles are allowed to proceed in one direction only;
 - (d) standing on a part of a road set aside for the parking of vehicles or as a stand for taxis or as a stand for buses or as a place at which such vehicles may stop for a longer time than is necessary for the taking up and setting down of passengers where compliance with those provisions would conflict with the provisions of any Order, Regulation or law governing the use of such part of a road for that purpose; or
 - (e) waiting to set down or pick up passengers in accordance with directions given by the Minister in regard to such setting down or picking up.

109 Passengers on motor cycles

If any person in addition to the driver is carried astride a 2-wheeled motor cycle on a road (whether a sidecar is attached to it or not) suitable supports or rests for the feet shall be available on the motor cycle for that person.

110 Obstruction of emergency vehicles

When warned of the approach of an emergency vehicle either by its distinctive luminous devices prescribed in the Lighting Order or by its distinctive audible device specified in Article 37(5), or by both devices, every road user must leave room clear for it to pass on the carriageway and, if necessary, to stop.

111 Driver's control

No person shall drive or cause or permit any other person to drive, a motor vehicle on a road if the person is in such a position that the person cannot have proper control of the vehicle or have a full view of the road and traffic ahead.

112 Opening of doors

No person shall open, or cause or permit to be opened, any door of a vehicle on a road so as to injure or endanger any person.

113 Reversing

No person shall drive, or cause or permit to be driven, a motor vehicle backwards on a road further than may be requisite for the safety or reasonable convenience of the occupants of the vehicle or other traffic, unless it is a road roller or is engaged in the construction, maintenance or repair of the road.

114 Leaving motor vehicles unattended

- (1) Save as provided in paragraph (2), no person shall leave, or cause or permit to be left, on a road a motor vehicle which is not attended by a person licensed to drive it unless the engine is stopped and any parking brake with which the vehicle is required to be equipped is effectively set.
- (2) The requirement specified in paragraph (1) as to the stopping of the engine shall not apply in respect of a vehicle –
 - (a) being used for ambulance, fire brigade or police purposes; or
 - (b) in such a position and condition as not to be likely to endanger any person or property and engaged in an operation which requires its engine to be used to –
 - (i) drive machinery forming part of, or mounted on, the vehicle and used for purposes other than driving the vehicle, or
 - (ii) maintain the electrical power of the batteries of the vehicle at a level required for driving that machinery or apparatus.

- (3) In this Article “parking brake” means a brake fitted to a vehicle in accordance with requirement 16 or 18 in Schedule 2.

115 Securing of suspended implements

Where a vehicle is fitted with apparatus or appliance designed for lifting and part of the apparatus or appliance consists of a suspended implement, the implement shall at all times while the vehicle is in motion on a road and when the implement is not attached to any load supported by the appliance or apparatus be so secured either to the appliance or apparatus or to some part of the vehicle that no danger is caused or is likely to be caused to any person on the vehicle or on the road.

116 Television sets

- (1) No person shall drive, or cause or permit to be driven, a motor vehicle on a road, if the driver is in such a position as to be able to see, whether directly or by reflection, a television receiving apparatus or other cinematographic apparatus used to display anything other than information –
- (a) about the state of the vehicle or its equipment;
 - (b) about the location of the vehicle and the road on which it is located;
 - (c) to assist the driver to see the road adjacent to the vehicle; or
 - (d) to assist the driver to reach the driver’s destination.
- (2) In this Article “television receiving apparatus” means any cathode ray tube carried on a vehicle on which there can be displayed an image derived from a television broadcast, a recording or a camera or computer.

PART 5

TESTING OF VEHICLES ETC

117 Testing of vehicles

- (1) A police or traffic officer may test all or any parts or component parts of any vehicle, on a road or, with the consent of the owner of the premises, on any premises where the vehicle is.
- (2)
- (a) The power conferred by this Article to test a vehicle on the premises where the vehicle is shall not be exercised unless either the owner of the vehicle consents or notice of the date and time at which it is proposed to carry out the test has been given to the owner in accordance with sub-paragraph (b);
 - (b) notice shall be –
 - (i) given to the owner of the vehicle personally,
 - (ii) left at the owner’s address not less than 24 hours before the proposed test, or

- (iii) sent not less than 48 hours before the proposed test by registered post to the owner at the owner's address;
 - (c) for the purposes of this Part, the owner of the vehicle shall be deemed to be, in the case of a vehicle which is –
 - (i) for the time being registered under the 1993 Law, the person appearing as the owner of the vehicle in the register kept by the Inspector of Motor Traffic in pursuance of that Law,
 - (ii) under a trade licence, the holder of the licence, and
 - (iii) used under an international circulation permit, the person to whom the permit was issued,and in the case of clauses (i) and (ii) the address of the owner as shown in the register may be treated as the owner's address.
- (3) Paragraph (2) shall not apply in the case of a test made within 48 hours of an accident to which Article 52 of the Law applies and in which the vehicle has been involved.
- (4) A person empowered under paragraph (1) shall produce evidence of the person's authorization if required to do so.
- (5) For the purposes of paragraph (1) the person testing a vehicle may drive it, whether on a road or elsewhere.
- (6) In this Part –
 - (a) "test" includes "inspect"; and
 - (b) references to a vehicle include references to a trailer drawn by it.

118 Defect notice

- (1) If, following a test under Article 117, a police or traffic officer is of the opinion that a vehicle contravenes any provision of this Order the police or traffic officer may serve a notice (in this Article referred to as a "defect notice") on the owner of the vehicle.
- (2) A defect notice shall be in such form as the Minister may specify and shall –
 - (a) state the provision of the Order which is contravened;
 - (b) require the owner to remedy the defect causing the contravention; and
 - (c) specify the date, time and place at which the owner shall produce the vehicle for a further test to ascertain whether the defect has been remedied.
- (3) If, following a test under Article 117, a police or traffic officer is of the opinion that a more detailed test of a vehicle is required to satisfy the police or traffic officer that the vehicle does not contravene any provision of this Order the police or traffic officer may serve a notice on the owner of the vehicle, specifying the date, time and place at which the owner shall produce it for the purpose of a more thorough test.
- (4) A defect notice may be issued following a test under paragraph (3).
- (5) A defect notice and a notice under paragraph (3) shall be –
 - (a) served on the owner personally;

- (b) left at the owner's address; or
- (c) sent to the owner by registered post.

119 Impounding of vehicles

- (1) If, following a test under Article 117, it appears to a police or traffic officer that, owing to any defect in the vehicle, driving it or driving it for any particular purpose would involve a danger of injury to any person the police or traffic officer may impound the vehicle until such time as the owner arranges for the vehicle to be towed to –
 - (i) the Driver and Vehicle Standards test station at La Route de Veulle, St. Helier, or such other place as the Minister may designate for the purpose of further testing, or
 - (ii) a garage for repairs,
 - (iii) a place where it may be disposed of for scrap.
- (2) If the vehicle is towed to a garage for repairs a police or traffic officer may serve a notice on the owner requiring the owner to produce the vehicle at a date, time and place specified in the notice for a test to ascertain whether the defects have been remedied.
- (3) If the owner fails to deal with the vehicle as required by paragraph (1), a police or traffic officer shall arrange for the vehicle to be towed away and the cost of doing so shall be recoverable from the owner as a civil debt.
- (4) The owner of a vehicle shall remove it from the Driver and Vehicle Standards test station or from any other place to which it has been taken for test within 7 days of receipt of a notice from a police or traffic officer requiring the owner to do so.
- (5) A notice under paragraph (2) or (4) shall be –
 - (a) served on the owner;
 - (b) left at the owner's address; or
 - (c) sent to the owner by registered post.

120 Power to require certificates of compliance

- (1) The Minister may require the owner of any class or classes of vehicle, to which Article 120A does not apply, to obtain a certificate of compliance certifying that the vehicle complies with those provisions of this Order listed in the certificate.¹⁹
- (1A) Before a certificate of compliance is issued the examiner shall examine the vehicle.²⁰
- (1B) The fee for an examination for a certificate of compliance is £201.70, but where the vehicle does not comply it may be submitted for re-examination within 14 days and the fee for the re-examination is half of the fee for the first examination.²¹
- (2) The Minister may designate persons (in this Article referred to as “examiners”) to examine vehicles and issue certificates of compliance under this Article, and no person, other than one so designated, shall issue a certificate of compliance.
- (3) A certificate of compliance shall be in such form as the Minister shall specify.

- (4) The Inspector of Motor Traffic shall issue written instructions to examiners regarding the standards of compliance as to which they must be satisfied and the manner in which those standards are to be tested or checked.
- (5) If an examiner fails to carry out the examiner's functions under this Article to the satisfaction of the Minister the examiner shall cease to be designated for that purpose and shall be notified accordingly.
- (6) A person aggrieved by a notification under paragraph (5) may within 28 days after the day on which the person is notified appeal to the Inferior Number of the Royal Court the decision of which shall be final and without appeal, but without prejudice to the right of the Inferior Number of the Royal Court to refer the matter to the Superior Number of the Royal Court.
- (7) The owner of a vehicle required to obtain a certificate of compliance under paragraph (1) shall produce that certificate to a police or traffic officer within 7 days of being required to do so, and shall not use or permit to be used a vehicle on a road or public place when a valid certificate of compliance in respect of that vehicle is not in force.
- (8) Where a certificate of compliance is refused, the examiner shall issue a notification of the refusal, stating the grounds of the refusal, and a person aggrieved by the refusal or the grounds of the refusal may appeal to the Minister.
- (9) On any such appeal the Minister shall cause a further examination to be made and either issue a certificate of compliance or issue a notification of the refusal stating the grounds of the refusal.

120A Annual examination and certificate of compliance for certain goods vehicles and trailers used for business²²

- (1) This Article applies, subject to paragraph (8), to a vehicle (a "relevant vehicle") that –
 - (a) is –
 - (i) a large goods vehicle,
 - (ia) a medium-sized goods vehicle,
 - (ii) a semi-trailer, or
 - (iii) a trailer, the unladen weight of which exceeds 1,020 kg;
 - (b) is used in the course of a business; and
 - (c) is not –
 - (i) an agricultural motor vehicle,
 - (ii) an agricultural tractor,
 - (iii) an agricultural trailer,
 - (iv) an agricultural trailed appliance, or
 - (v) a vehicle in respect of which there is in force a licence under Article 78 of the Law.²³
- (2) A person shall not use a relevant vehicle on a road, and the owner of a relevant vehicle shall not cause or permit it to be used on a road, unless –

- (a) the vehicle has been examined under paragraph (4) no more than one year before it is so used; and
 - (b) an indicator, from a certificate of compliance issued under paragraph (5) in respect of that examination, is displayed on the vehicle in such a manner as to be clearly visible from the outside of the vehicle.
- (3) A person using a relevant vehicle on a road shall, if required to do so by a police or traffic officer, permit that officer to inspect the indicator displayed on the vehicle under paragraph (2)(b).
- (4) The examination referred to in paragraph (2)(a) is an examination that –
 - (a) tests for compliance with all of the requirements of this Order that apply to the relevant vehicle;
 - (b) is of all of the parts and component parts of the vehicle to which those requirements apply; and
 - (c) is carried out by an examiner designated under Article 120(2), as applied by paragraph (7) of this Article.
- (5) If a relevant vehicle is found on an examination under paragraph (4) to comply with all of the requirements of this Order that apply to that vehicle, the examiner shall issue a certificate of compliance that –
 - (a) certifies that the vehicle did so comply;
 - (b) lists the requirements for which compliance was tested;
 - (c) specifies the date on which the examination was concluded;
 - (d) includes a detachable indicator for display in the vehicle; and
 - (e) is otherwise in such form as the Minister shall specify.
- (6) Articles 118 and 119 apply following an examination under paragraph (4) as they do following a test under Article 117.
- (7) Articles 120(1B), (2), (4), (5), (6), (8) and (9) apply in respect of a certificate of compliance under this Article as they apply in respect of a certificate of compliance under Article 120.
- (8) Paragraphs (2) and (3) do not apply to a relevant vehicle until whichever is the sooner of –
 - (a) the relevant date for that type of vehicle, being –
 - (i) if the vehicle is a medium-sized goods vehicle, 14th May 2020, or
 - (ii) if the vehicle is any other relevant vehicle, 14th May 2019; and
 - (b) the date, if any, on which, by appointment with the Inspector of Motor Traffic, the vehicle is first submitted for examination under paragraph (4).²⁴

121 Lost or defaced certificate of compliance

- (1) If the holder of a current certificate of compliance, issued under Article 120 or 120A, satisfies the Minister that it has been lost or defaced, the Minister shall authorize the issue of a duplicate certificate, on payment of a fee of £10.20.²⁵

- (2) A duplicate certificate issued under paragraph (1) shall have the same effect as the original certificate.

PART 6

MISCELLANEOUS AND GENERAL

122 Citation

This Order may be cited as the Motor Vehicles (Construction and Use) (Jersey) Order 1998.

SCHEDULE 1²⁶

(Article 1(1))

COMMUNITY DIRECTIVES AND ECE REGULATIONS

TABLE 1

Community Directives

1	2	3				4	
<i>Item</i>	<i>Reference No.</i>	<i>Community Directive</i>				<i>Item No. In Schedule 1 to: –</i>	
		(a) Date	(b) Official Journal Reference	(c) Subject matter	(d) Previous Directives included	(a) The Type Approval (Great Britain) Regulations	(b) The Type Approval for Goods Vehicles Regulations
1	70/157	6.2.70	L42, 23.2.70, p.16	The permissible sound level and the exhaust system of motor vehicles			
2	70/220	20.3.70	L76, 6.4.70, p.1	Measures to be taken against air pollution by gases from spark ignition engines of motor vehicles			
3	70/221	20.3.70	L76, 6.4.70, p.23	Liquid fuel tanks and rear protective devices for motor vehicles and their trailers			
4	70/388	27.7.70	L176, 10.8.70, p.12	Audible warning devices for motor vehicles			
5	71/127	1.3.71	L68, 22.3.71, p.1	The rear-view mirrors of motor vehicles		10	
6	71/320	26.9.71	L202, 6.9.71, p.37	The braking devices of certain categories of motor vehicles and their trailers			
7	72/245	20.6.72	L152, 6.7.72, p.15	The suppression of radio interference produced by spark ignition engines fitted to motor vehicles		2A	5A
8	72/306	2.8.72	L190, 20.8.72, p.1	The emission of pollutants from diesel engines for use in vehicles		5	3
9	73/350	7.11.73	L321, 22.11.73, p.33	The permissible sound level and the	70/157		4A

1	2	3			4		
Item	Reference No.	Community Directive			Item No. In Schedule 1 to: –		
				exhaust system of motor vehicles			
10	74/132	11.2.74	L74, 19.3.74, p.7	The braking devices of certain categories of motor vehicles and their trailers	71/320		
11	74/151	4.3.74	L84, 28.3.74, p.25	Parts and characteristics of agricultural motor vehicles (see Note 1)			
12	74/290	28.5.74	L159, 15.6.74, p.61	Measures to be taken against air pollution by gases from spark ignition engines for motor vehicles	70/220		
13	74/346	25.6.74	L191, 15.7.74, p.1	Rear view mirrors for agricultural motor vehicles (see Note 1)			
14	74/347	25.6.74	L191, 15.7.74, p.5	Field of vision and windscreen wipers for agricultural motor vehicles (see Note 1)			
15	74/483	17.9.74	L266, 2.10.74, p.4	External projections of motor vehicles		19	
16	75/322	20.5.75	L147, 9.6.75, p.28	Suppression of radio interference from spark ignition engines of agricultural motor vehicles (see Note 1)			
17	75/443	26.6.75	L196, 26.7.75, p.1	Reverse and speedometer equipment of motor vehicles		20	
18	75/524	25.7.75	L236, 8.9.75, p.3	The braking devices of certain categories of motor vehicles and their trailers	71/320 as amended by 74/132	13A	
19	76/114	18.12.75	L24, 30.1.76, p.1	Statutory plates and inscriptions for motor vehicles and trailers			
20	76/115	18.12.75	L24, 30.1.76, p.6	Anchorage for motor vehicle seat belts		12A	
21	76/432	6.4.76	L122, 8.5.76, p.1	Braking devices of agricultural vehicles (see Note 1)			
22	77/102	30.11.76	L32, 3.2.77, p.32	Measures to be taken against air pollution by gases	70/220 as amended by 74/290		

1	2	3			4		
Item	Reference No.	Community Directive			Item No. In Schedule 1 to: –		
				from spark ignition engines of motor vehicles			
23	77/212	8.3.77	L66, 12.3.77, p.33	The permissible sound level and the exhaust system of motor vehicles	70/157 as amended by 73/350	14B	4B, 4C, 4D
24	77/537	28.6.77	L220, 29.8.77, p.38	Emission of pollution from diesel engines for agricultural motor vehicles (see Note 1)			
25	77/541	28.6.77	L220, 29.8.77, p.95	Seat belts and restraint systems for motor vehicles		12A	
26	77/649	27.9.77	L267, 19.10.77, p.1	Field of vision of motor vehicle drivers			
27	78/318	21.12.77	L81, 28.3.78, p.49	Wiper and washer systems of motor vehicles		22	
28	78/507	19.5.78	L155, 13.6.78, p.31	Statutory plates and inscriptions for motor vehicles and trailers	76/114		
29	78/549	12.6.78	L168, 26.6.78, p.45	Wheel guards of motor vehicles			
30	78/665	14.7.78	L223, 14.8.78, p.48	Measures to be taken against air pollution by gases from spark ignition engines of motor vehicles	70/220 as amended by 74/290 and 77/102	4B, 4C	2
31	78/1015	23.11.78	L349, 13.12.78, p.21	The permissible sound level and exhaust system of motor cycles			
32	79/488	18.4.79	L128, 26.5.79, p.1	External projections of motor vehicles	74/283	19A	
33	79/489	18.4.79	L128, 26.5.79, p.12	The braking devices of certain categories of motor vehicles and their trailers	71/320 as amended by 74/132 and 75/524	13B	6, 6C
34	79/490	18.4.79	L128, 26.5.79, p.22	Liquid fuel tanks and rear under-run protection	70/221		
35	79/795	20.7.79	L239, 22.9.79, p.1	The rear-view mirrors of motor vehicles	71/127	10A	
36	79/1073	22.11.79	L331, 27.12.79, p.20	Field of vision and windscreen wipers for agricultural motor vehicles	74/347		
37	80/780	22.7.80	L229, 30.8.80, p.49	Rear-view mirrors for motor cycles			
38	80/1269	16.12.80	L375, 31.12.80, p.46	The engine power of motor vehicles			

1	2	3				4	
<i>Item</i>	<i>Reference No.</i>	<i>Community Directive</i>				<i>Item No. In Schedule 1 to: –</i>	
39	81/334	13.4.81	L131, 18.5.81, p.6	The permissible sound level and exhaust system of motor vehicles	70/157 as amended by 73/350 and 77/212	14C	4B, 4C, 4D
40	81/575	29.7.81	L209, 29.7.81. p30	Anchorage for motor vehicle seat belts	76/115	12A	
41	81/576	29.7.81	L209, 29.7.81, p.32	Seat belts and restraint systems for motor vehicles	77/541	12A	
42	81/643	29.7.81	L231, 15.8.81, p41	Field of vision of motor vehicle drivers	77/649		
43	82/318	2.4.82	L139, 19.5.82, p.9	Anchorage for motor vehicle seat belts	76/115 as amended by 81/575	12A	
44	82/319	2.4.82	L139, 19.5.82, p.17	Seat belts and restraint systems for motor vehicles	77/541 as amended by 81/576	12A	
45	82/890	17.12.82	L378, 31.12.82, p.45	Agricultural motor vehicles			
46	83/351	16.6.83	L197, 20.7.83, p.1	Air pollution by gases from positive ignition engines of motor vehicles	70/220 as amended by 74/290, 77/102 and 78/665	4C	
47	84/372	3.7.84	L196, 26.7.84, p.47	The permissible sound level and exhaust system of motor vehicles	70/157 as amended by 73/350, 77/212 and 81/334		
48	84/424	3.9.84	L238, 6.9.84, p.31	The permissible sound level and exhaust system of motor vehicles	70/157 as amended by 73/350, 77/212, 81/334 and 84/372		
49	85/3	19.12.84	L2, 3.1.85, p.14	The weights, dimensions and other technical characteristics of certain road vehicles			
50	82/205	18.2.85	L90, 29.3.85, p.1	Mirrors	71/127 as amended by 79/795	10B	
51	85/210	20.3.85	L96, 3.4.85, p.25	The lead content of petrol			
52	85/647	23.12.85	L380, 31.12.85, p.1	The braking devices of certain motor vehicles and their trailers	71/320 as amended by 74/132, 75/524 and 79/489		
53	86/360	24.7.86	L217, 5.8.86, p.19	The weights, dimensions and other technical characteristics of certain road vehicles	85/3		
54	85/562	6.11.86	L327,	Mirrors	71/127 as		

1	2	3			4		
Item	Reference No.	Community Directive			Item No. In Schedule 1 to: –		
			27.11.86, p.49		amended by 79/795 and 85/205		
55	87/56	18.12.86	L24, 27.1.87, p.42	The permissible sound level and exhaust system of motor cycles	78/1015		
56	88/76	3.12.87	L36, 9.2.88, p.1	Measures to be taken against air pollution by gases from the engines of motor vehicles	70/220 as amended by 74/290, 77/102, 78/665 and 83/351	4D, 2B	
57	89/297	13.4.89	L124, 5.5.89, p.1	Lateral protection (side guards) of certain motor vehicles and their trailers			
58	88/77	3.12.87	L36, 9.2.88, p.33	Measures to be taken against the emission of gaseous pollutants from diesel engines for use in vehicles		4E	2D
59	88/194	24.3.88	L92, 9.4.88, p.47	The braking devices of certain categories of motor vehicles and their trailers	71/320 as amended by 74/132, 75/524, 79/489 and 85/647		
60	88/321	16.5.88	L147, 14.6.88, p.77	Mirrors	71/127 as amended by 79/795, 85/205 and 86/562		
61	88/195	24.3.88	L92, 9.4.88, p.50	Engine power of motor vehicles	80/1269		
62	88/366	17.5.88	L181, 12.7.88, p.40	Field of vision of motor vehicle drivers	77/649 as amended by 81/643		
63	88/218	11.4.88	L98, 15.4.88, p.48	The weights dimensions and other technical characteristics of certain road vehicles	85/3 as amended by 86/360		
64	88/436	16.6.88	L214, 6.8.88, p.1	Measures to be taken against air pollution by gases from engines of motor vehicles (restriction of particulate pollution emissions from diesel engines)	70/220 as amended by 74/290, 77/102, 78/665, 83/351 and 88/76	27	
65	89/235	13.3.89	L98, 11.4.89, p.1	The permissible sound level and exhaust system of	78/1015 as amended by 87/56		

1	2	3			4		
<i>Item</i>	<i>Reference No.</i>	<i>Community Directive</i>			<i>Item No. In Schedule 1 to: –</i>		
				motor cycles			
66	89/338	27.4.89	L142, 25.5.89, p.3	The weights dimensions and other technical characteristics of certain road vehicles	85/3 as amended by 86/360 and 88/218		
67	89/458	18.7.89	L226, 3.8.89, p.1	Measures to be taken against air pollution by emissions from motor vehicles	70/220 as amended by 74/290, 77/102, 78/665, 83/351, 88/76 and 88/436		
68	89/460	18.7.89	L226, 3.8.89, p.5	The weights dimensions and other technical characteristics of certain road vehicles	85/3 as amended by 86/360, 88/218 and 89/338		
69	89/461	18.7.89	L226, 3.8.89, p.7	The weights dimensions and other technical characteristics of certain road vehicles	85/3 as amended by 86/360, 88/218, 89/338 and 89/460		
70	90/628	30.10.90	L341, 6.12.90, p.1	Safety belts and restraint systems of motor vehicles	77/541 as amended by 81/576 and 82/319	12A	
71	90/269	30.10.90	L341, 6.12.90, p.14	Anchorage for motor vehicle safety belts	76/115 as amended by 81/575 and 82/318	12A	
72	90/630	30.10.90	L341, 6.12.90, p.20	Field of vision of motor vehicle drivers	77/649 as amended by 81/643 and 88/366		
73	91/60	4.2.91	L37, 9.2.91, p.37	The weights dimensions and other technical characteristics of certain vehicles	85/3 as amended by 86/360, 88/218, 89/338, 89/460 and 89/641		
74	91/226	27.3.91	L103, 23.4.91, p.5	Spray-suppression systems of certain categories of motor vehicles and their trailers			
75	92/7	10.2.91	L57, 2.3.92, p.29	The weights dimensions and other technical characteristics of certain road vehicles	85/3 as amended by 83/360, 88/218, 89/338, 89/460 and 89/641		
76	91/441	26.6.91	L242, 30.8.91, p.1	Measures to be taken against air	70/220 as amended by	4G	2F

1	2	3			4		
<i>Item</i>	<i>Reference No.</i>	<i>Community Directive</i>			<i>Item No. In Schedule 1 to: –</i>		
				pollution by emission from motor vehicles	74/290, 77/102, 78/665, 83/351, 88/76, 88/436 and 89/458		
77	91/542	1.10.91	L295, 25.10.91, p.1	Measures to be taken against the emission of gaseous pollutants from diesel engines for use in vehicles	88/77	4H	2G
78	92/22	31.3.92	L129, 14.5.92, p.11	Safety glazing and glazing materials on motor vehicles and their trailers			
79	92/23	31.3.92	L129, 14.5.92, p.95	Tyres of motor vehicles and their trailers and their filling			
80	92/24	31.3.92	L129, 14.5.92, p.154	Speed limitation devices or similar speed limitation onboard certain categories of motor vehicles			
81	93/59	28.6.93		Measures to be taken against air pollution by emissions from motor vehicles	70/220 as amended by 74/290, 77/102, 78/665, 83/351, 88/76, 88/436, 89/458 and 91/441	4K	2I
82	94/12	23.3.94	L100, 19.4.94, p.42	Measures to be taken against air pollution by emissions from motor vehicles	70/22 as amended by 74/290, 77/102, 78/665, 83/351, 88/76, 88/436, 89/458, 91/441 and 93/59	4L	2J
83	96/38	17.6.96	L187, 26.7.96, p.95	Anchorage for motor vehicle safety belts	76/115 as amended by 81/575, 82/318, 90/629 and 2005/41		

TABLE 2
ECE Regulations

1	2	3					4
<i>Item</i>	<i>Referen ce No.</i>	<i>ECE Regulations</i>					<i>Item No In Schedule 1 to –</i>
		(a) Numbe r	(b) Date	(c) Subject matter	(d) Date of Amendment	(a) The Type Approval (Great Britain) Regulation s	(b) The Type Approval for Goods Vehicles Regulation s
1	10	10	17.12.68	Radio interference suppression	–	2	5
2	10.01	10	17.12.68	Radio interference suppression	19.3.78	2A	5A
3	13.03	13	29.5.69	Brakes	4.1.79	13C, 13D	6A, 6B, 6D
4	13.04	13	29.5.69	Brakes	11.8.81	13C, 13D	6A, 6B, 6D
5	13.05	13	29.5.69	Brakes	26.11.84	–	–
6	13.06	13	29.5.69	Brakes	22.11.90	–	–
7	14	14	30.1.70	Anchorage for seat belts	–	–	–
8	14.01	14	30.1.70	Anchorage for seat belts	28.4.76	12A	–
9	14.02	14	30.1.70	Anchorage for seat belts	22.11.84	12A	–
9A	14.03	14	30.1.70	Anchorage for seat belts	29.1.92		
9B	14.03	14	30.1.70	Anchorage for seat belts	29.1.92	12A	
9C	14.04	14	30.1.70	Anchorage for seat belts	18.1.98		
9D	14.05	14	30/1/70	Anchorage for seat belts	4.2.99		
10	15.03	15	11.3.70	Emission of gaseous pollutants	6.3.78	4B	2
11	15.04	15	11.3.70	Emission of gaseous pollutants	20.10.81	4C	2
12	16.03	16	14.8.70	Seat belts and restraint systems	9.12.79	12A	–
13	24.01	24	23.8.71	Emission of pollutants by a diesel engine	11.9.73	5	3
14	24.02	24	23.8.71	Emission of pollutants by a diesel engine	11.2.80	5A	3A
15	24.03	24	23.8.71	Emission of pollutants by a diesel engine	20.4.86	–	–
16	26.01	26	28.4.72	External projections	11.9.73	19	–
17	30	30	1.4.75	Pneumatic tyres for motor vehicles and their trailers	–	17, 17A	–
18	30	30.01	1.4.75	Pneumatic tyres for motor vehicles and their trailers	25.9.77	17, 17A	–
19	30.02	30	1.4.75	Pneumatic tyres for motor vehicles	5.10.87	17, 17A	–

1	2	3					4
<i>Item</i>	<i>Referen ce No.</i>	<i>ECE Regulations</i>					<i>Item No In Schedule 1 to –</i>
				and their trailers			
20	34	34	25.7.75	Prevention of fire risks	–	–	–
21	34.01	34	25.7.75	Prevention of fire risks	18.1.79	–	–
22	36	36	12.11.75	Construction of public service vehicles	–	–	–
23	39	39	11.7.78	Speedometers	–	20	–
24	43	43	15.9.80	Safety glass and glazing materials	–	15B	–
25	43.01	43	15.9.80	Safety glass and glazing materials	12.11.82	15B	–
26	44	44	1.2.81	Child restraints	–	–	–
27	44.01	44	1.2.81	Child restraints	1.2.84	–	–
28	46.01	46	21.10.84	Mirrors	30.5.88	–	–
29	49	49	15.4.82	Emissions of gaseous pollutants	–	–	–
30	49.01	49	14.5.90	Emissions of gaseous pollutants	–	–	–
31	49.02	49	15.4.82	Emissions of gaseous pollutants	30.12.92	–	–
32	54	54	1.3.83	Pneumatic tyres for commercial vehicles and their trailers	–	17A	–
33	64	64	1.8.85	Vehicles with temporary-use spare wheels/tyres	–	–	–
34	78	78	15.10.88	Brakes	–	–	–
35	78.01	78	15.10.88	Brakes	22.11.90	–	–
36	83	83	5.11.89	Emissions of gaseous pollutants	–	4F	2H
37	83.01	83	5.11.89	Emissions of gaseous pollutants	30.12.92	4K	2F

SCHEDULE 2

(Article 16)

BRAKING REQUIREMENTS

1. The braking requirements referred to in Article 16(4) are set out in the Table and are to be interpreted in accordance with paragraphs 2 to 5.

TABLE

(Schedule 2)

Number	Requirement
1	<p>The vehicle shall be equipped with –</p> <ul style="list-style-type: none"> (a) one efficient braking system having 2 means of operation; (b) one efficient split braking system having one means of operation; <p>or</p> <ul style="list-style-type: none"> (c) 2 efficient braking systems each having a separate means of operation, <p>and, in the case of a vehicle first used on or after 1st January 1968, no account shall be taken of a multi-pull means of operation unless, at first application, it operates a hydraulic, electric or pneumatic device which causes the application of brakes with total braking efficiency not less than 25%.</p>
2	<p>The vehicle shall be equipped with –</p> <ul style="list-style-type: none"> (a) one efficient braking system having 2 means of operation; or (b) 2 efficient braking systems each having a separate means of operation.
3	The vehicle shall be equipped with an efficient braking system.
4	<p>The braking system shall be so designed that in the event of failure of any part (other than a fixed member or a brake shoe anchor pin) through or by means of which the force necessary to apply the brakes is transmitted, there shall still be available for application by the driver brakes sufficient under the most adverse conditions to bring the vehicle to rest within a reasonable distance. The brakes so available shall be applied to –</p> <ul style="list-style-type: none"> (a) in the case of a track-laying vehicle, one track on each side of the vehicle; (b) in the case of a wheeled motor vehicle, one wheel if the vehicle has 3 wheels and otherwise to at least half the wheels; and (c) in the case of a wheeled trailer, at least one wheel if it has only 2 wheels and otherwise at least 2 wheels. <p>This requirement applies to the braking systems of both a trailer and the vehicle by which it is being drawn except that if the drawing vehicle complies with Article 15, Community Directive 79/489, 85/647, 88/194 or 91/422 or ECE Regulation 13.03, 13.04, 13.05 or 13.06 the requirement applies only to the braking system of the drawing vehicle.</p>

Number	Requirement
	It does not apply to vehicles having split braking systems (which are subject to Article 18(5)(b)) or to road rollers. (The expressions “part” and “half the wheels” are to be interpreted in accordance with paragraphs (3) and (4) respectively).
5	The braking system shall be so designed and constructed that, in the event of the failure of any part thereof, there shall be available for application by the driver a brake sufficient under the most adverse conditions to bring the vehicle to rest within a reasonable distance.
6	The braking system of a vehicle, when drawing a trailer which complies with Article 15, Community Directive 79/489, 85/647, 88/194 or 91/422, or ECE Regulation 13.03, 13.04, 13.05 or 13.06 shall be so constructed that, in the event of a failure of any part (other than a fixed member or brake shoe anchor pin) of the service braking system of the drawing vehicle (excluding the means of operation of a split braking system) the driver can still apply brakes to at least one wheel of the trailer, if it has only 2 wheels, and otherwise to at least 2 wheels, by using the secondary braking system of the drawing vehicle. (The expression “part” is to be interpreted in accordance with paragraph 3.)
7	The application of any means of operation of a braking system shall not affect or operate the pedal or hand lever of any other means of operation.
8	The braking system shall not be rendered ineffective by the non-rotation of the engine of the vehicle or, in the case of a trailer, the engine of the drawing vehicle (steam-propelled vehicles, other than locomotives and buses, are excluded from this requirement).
9	At least one means of operation shall be capable of causing brakes to be applied directly, and not through the transmission gear, to at least half the wheels of the vehicle. This requirement does not apply to a works truck with an unladen weight not exceeding 7370 kg, or to an industrial tractor; and it does not apply to a vehicle with more than 4 wheels if – (a) the drive is transmitted to all wheels other than the steering wheels without the interposition of a differential driving gear or similar mechanism between the axles carrying the driving wheels; (b) the brakes applied by one means of operation apply directly to 2 driving wheels on opposite sides of the vehicle; and (c) the brakes applied by another means of operation act directly on all the other driving wheels. (The expression “half the wheels” is to be interpreted in accordance with paragraph (4)).
10	The brakes of a trailer shall come into operation automatically on its overrun or, in the case of a track-laying trailer drawn by a vehicle having steerable wheels at the front or a wheeled trailer, the driver of, or some other person on, the drawing vehicle or on the trailer shall be able to apply the brakes on the trailer.
11	The brakes of a trailer shall come into operation automatically on its overrun or the driver of the drawing vehicle shall be able to apply brakes to all the wheels of the trailer, using the means of operation which applies the service brakes of the drawing vehicle.
12	The brakes of the vehicle shall apply to all wheels other than the

Number	Requirement
	steering wheels.
13	The brakes of the vehicle shall apply to at least 2 wheels.
14	The brakes of the vehicle shall apply in the case of a wheeled vehicle to at least 2 wheels if the vehicle has no more than 4 wheels and to at least half the wheels if the vehicle has more than 4 wheels; and in the case of a track-laying vehicle to all the tracks.
15	The brakes shall apply to all the wheels.
16	<p>The parking brake shall be so designed and constructed that –</p> <ul style="list-style-type: none"> (a) in the case of a wheeled heavy motor car or motor car, its means of operation is independent of the means of operation of any split braking system with which the vehicle is fitted; (b) in the case of a motor vehicle other than a motor cycle or an invalid carriage, either – <ul style="list-style-type: none"> (i) it is capable of being applied by direct mechanical action without the intervention of any hydraulic, electric or pneumatic device, or (ii) the vehicle complies with requirement 15, and (c) it can at all times when the vehicle is not being driven or is left unattended be set so as – <ul style="list-style-type: none"> (i) in the case of a track-laying vehicle, to lock the tracks, and (ii) in the case of a wheeled vehicle, to prevent the rotation of at least one wheel in the case of a 3-wheeled vehicle and at least 2 wheels in the case of a vehicle with more than 3 wheels.
17	The parking brake shall be capable of being set so as effectively to prevent 2 at least of the wheels from revolving when the trailer is not being drawn.
18	<p>The parking brake shall be so designed and constructed that –</p> <ul style="list-style-type: none"> (a) in the case of a motor vehicle, its means of operation (whether multi-pull or not) is independent of the means of operation of any braking system required by Article 18 to have a total braking efficiency of not less than 50%; and (b) in the case of a trailer, its brakes can be applied and released by a person standing on the ground by a means of operation fitted to the trailer; and (c) in either case, its braking force, when the vehicle is not being driven or is left unattended (and in the case of a trailer, whether a braking force is applied by the driver using the service brakes of the drawing vehicle or by a person standing on the ground in the manner indicated in sub-paragraph (b)) can at all times be maintained in operation by direct mechanical action without the intervention of any hydraulic, electric or pneumatic device and, when so maintained, can hold the vehicle stationary on a gradient of at least 16% without the assistance of stored energy.

2. For the purposes of requirement 3 in the Table, in the case of a motor car or heavy motor car propelled by steam and not used as a bus, the engine shall be deemed to be an efficient braking system with one means of operation if the engine is capable of being reversed and, in the case of a vehicle first used on or after 1st

January 1927, is incapable of being disconnected from any of the driving wheels of the vehicle except by the sustained effort of the driver.

3. For the purpose of requirements 4 and 6 in the Table, in the case of a wheeled motor car and of a vehicle first used on or after 1st October 1938 which is a locomotive, a motor tractor, a heavy motor car or a track-laying motor car, every moving shaft which is connected to or supports any part of a braking system shall be deemed to be part of the system.
4. For the purpose of requirements 4, 9 and 14 in the Table, in determining whether brakes apply to at least half the wheels of a vehicle, not more than one front wheel shall be treated as a wheel to which brakes apply unless the vehicle is –
 - (a) a locomotive or motor tractor with more than 4 wheels;
 - (b) a heavy motor car or motor car first used before 1st October 1938;
 - (c) a motor car with an unladen weight not exceeding 1020 kg;
 - (d) a motor car which is a passenger vehicle but is not a bus;
 - (e) a works truck;
 - (f) a heavy motor car or motor car with more than 3 wheels which is equipped in respect of all its wheels with brakes which are operated by one means of operation; or
 - (g) a track-laying vehicle.
5. In this Schedule a “multi-pull means of operation” means a device forming part of a braking system which causes the muscular energy of the driver to apply the brakes of that system progressively as a result of successive applications of that device by the driver.

SCHEDULE 3

(Articles 40 and 41)

EXCLUSION OF CERTAIN VEHICLES FROM THE APPLICATION OF ARTICLE 40

PART 1

1. In this Part –

“EEC type approval certificate” means a certificate issued by a member state of the European Economic Community in accordance with Community Directive 70/220 as originally made or with any amendments which have from time to time been made before 5th September 1988;

“engine capacity” means in the case of a reciprocating engine, the nominal swept volume and, in the case of a rotary engine, double the nominal swept volume;

“relevant authority” means –

- (a) in relation to an EEC type approval certificate issued by the United Kingdom, the Secretary of State for Transport of the United Kingdom; and
- (b) in relation to an EEC type approval certificate issued by any other member state of the European Economic Community, the authority having power under the law of that state to issue that certificate.

2. The reference in this Schedule to an M1 category is a reference to a vehicle described as M1 in Council Directive 70/156/EEC of 6th February 1970 as amended at 5th September 1988.

3. A vehicle of a description in column 2 of the Table to this Part is excluded from the application of Article 40 if it is first used before the date specified in column 3 and the conditions specified in paragraph 4 are satisfied in respect to it on that date.

4. The conditions referred to in paragraph 3 are –

- (a) that the vehicle is a model in relation to which there is in force an EEC type approval certificate issued before 1st October 1989;
- (b) that the manufacturer of the vehicle has supplied to the relevant authority which issued the EEC type approval certificate, a certificate stating that adapting vehicles of that model to the fuel requirements specified in Annexes to Community Directive 88/76 would entail a change in material specification of the inlet or exhaust valve seats or a reduction in the compression ratio or an increase in the engine capacity to compensate for loss of power; and
- (c) that the relevant authority has accepted the certificate referred to in subparagraph (b).

TABLE

<i>Item</i>	<i>Description of vehicle</i>	<i>Date before which vehicle must be first used</i>
(1)	(2)	(3)
1	Vehicles with an engine capacity of less than 1400 cc.	1.4.92
2	Vehicles with an engine capacity of not less than 1400 cc and not more than 2,000 cc.	1.4.94
3	M1 category vehicles with an engine capacity of more than 2,000 cc and which – (a) are constructed or adapted to carry not more than 5 passengers excluding the driver; or (b) have a maximum gross weight of not more than 2,500 kg, not being, in either case, an off-road vehicle.	1.4.93

PART 2

Symbol indicating that vehicle can run on unleaded petrol



SCHEDULE 4

(Article 42)

GAS CONTAINERS

PART 1

1 Definitions relating to gas containers

In this Schedule, unless the context otherwise requires –

“gas container” means a container fitted to a motor vehicle or a trailer and intended for the storage of gaseous fuel for the purpose of the propulsion of the vehicle or the drawing vehicle, as the case may be;

“gas cylinder” means a container fitted to a motor vehicle or a trailer and intended for the storage of compressed gas for the purpose of the propulsion of the vehicle or the drawing vehicle, as the case may be;

“compressed gas” means a gaseous fuel under a pressure exceeding 1.0325 bar above atmospheric pressure;

“pipe line” means all pipes connecting a gas container or containers –

- (a) to the engine or the mixing device for the supply of a mixture of gas and air to the engine; and
- (b) to the filling point on the vehicle;

“pressure pipe line” means any part of a pipe line intended for the conveyance of compressed gas; and

“reducing valve” means an apparatus which automatically reduces the pressure of the gas passing through it.

2 Gas containers

Every gas container shall –

- (a) be securely attached to the vehicle in such manner as not to be liable to displacement or damage due to vibration or other cause; and
- (b) be so placed or insulated as not to be adversely affected by the heat from the exhaust system.

3 Pipe lines

- (1) Every pipe line shall be supported in such manner as to be protected from excessive vibration and strain.

- (2) No part of a pipe line shall be in such a position that it may be subjected to undue heat from the exhaust system.
- (3) Every pressure pipe line shall be made of steel solid drawn.
- (4) The maximum unsupported length of a pressure pipe line shall not exceed 920 mm.

4 Unions

- (1) Every union shall be so constructed and fitted that it will –
 - (a) not be liable to work or develop leakage when in use; and
 - (b) be readily accessible for inspection and adjustment.
- (2) No union on a pressure pipe line or on a gas cylinder shall contain a joint other than a metal to metal joint.

5 Reducing valves

Every reducing valve shall be –

- (a) so fitted as to be readily accessible; and
- (b) so constructed that there can be no escape of gas when the engine is not running.

6 Valves and cocks

- (1) Every valve or cock intended to be subject to a pressure exceeding 6.8948 bar shall be of forged steel or of brass or bronze complying with the specification contained in Part 2.
- (2) A valve or cock shall be fitted to the pipe line to enable the supply of gas from the container or containers to the mixing device to be shut off.
- (3)
 - (a) In the case of a pressure pipe line the valve or cock shall be placed between the reducing valve and the container or containers and shall be readily visible and accessible from the outside of the vehicle and a notice indicating its position and method of operation shall be affixed in a conspicuous position on the outside of the vehicle carrying the gas container or containers;
 - (b) In other cases, if the valve or cock is not so visible and accessible as indicated in sub-paragraph (a), a notice indicating its position shall be affixed in a conspicuous position on the outside of the vehicle carrying the container or containers.

7 Pressure gauges

Every pressure gauge connected to a pressure pipe line shall be so constructed as not to be liable to deterioration under the action of the particular gases employed and shall be so constructed and fitted that –

- (a) in the event of failure of such pressure gauge no gas can escape into any part of the vehicle;
- (b) it is not possible owing to leakage of gas into the casing of the pressure gauge for pressure to increase therein to such extent as to be liable to cause a breakage of the glass thereof; and
- (c) in the event of failure of such pressure gauge the supply of gas thereto may be readily cut off.

8 Charging connections

- (1) Every connection for charging a gas cylinder shall be outside the vehicle and in the case of a public service vehicle no such connection shall be within 610 mm of any entrance or exit.
- (2) An efficient shut-off valve shall be fitted as near as practicable to the filling point. Provided that in cases where compressed gas is not used a cock or an efficient non-return valve may be fitted in lieu thereof.
- (3) Where compressed gas is used an additional emergency shut-off valve shall be fitted adjacent to the valve referred to in sub-paragraph (2).
- (4) A cap shall be fitted to the gas filling point on the vehicle and where compressed gas is used this cap shall be made of steel with a metal to metal joint.

9 Trailers

- (1) Where a trailer is used for the carriage of a gas cylinder, a reducing valve shall be fitted on the trailer.
- (2) No pipe used for conveying gas from a trailer to the engine of a vehicle shall contain compressed gas.

10 Construction, etc. of system

Every part of a gas container propulsion system shall be –

- (a) so placed or protected as not to be exposed to accidental damage and shall be soundly and properly constructed of suitable and well-finished materials capable of withstanding the loads and stresses likely to be met with in operation and shall be maintained in an efficient, safe and clean condition; and
- (b) so designed and constructed that leakage of gas is not likely to occur under normal working conditions, whether or not the engine is running.

PART 2**SPECIFICATION FOR BRASS OR BRONZE VALVES****1 Manufacture of valves**

The stamping or pressing from which each valve is manufactured shall be made from bars produced by (a) extrusion, (b) rolling, (c) forging, (d) extrusion and drawing, or (e) rolling and drawing.

2 Heat treatment

Each stamping or pressing shall be heat treated so as to produce an equiaxed microstructure in the material.

3 Freedom from defects

All stampings and pressings and the bars from which they are made shall be free from cracks, laminations, hard spots, segregated materials and variations in composition.

4 Tensile test

Tensile tests shall be made on samples of stampings or pressings taken at random from any consignment. The result of the tensile test shall conform to the following conditions –

Yield Stress – Not less than 231.6 N/mm²

Ultimate Tensile Stress – Not less than 463.3 N/mm²

Elongation on 50 mm gauge length – Not less than 25%.

Note – when the gauge length is less than 50 mm the required elongation shall be proportionately reduced.

The fracture test piece shall be free from piping and other defects (see paragraph 3).

SCHEDULE 5

(Articles 42 and 103)

GAS SYSTEMS

1 Definitions

In this Schedule –

“check valve” means a device which permits the flow of gas in one direction and prevents the flow of gas in the opposite direction;

“design pressure” means the pressure which a part of a gas system has been designed and constructed safely to withstand;

“double-check valve” means a device which consists of 2 check valves in series and which permits the flow of gas in one direction and prevents the flow of gas in the opposite direction;

“exceed flow valve” means a device which automatically and instantaneously reduces to a minimum the flow of gas through the valve when the flow rate exceeds a set value;

“fixed gas container” means a gas container which is attached to a vehicle permanently and in such a manner that the container can be filled without being moved;

“gas container” means any container, not being a container for the carriage of gas as goods, which is fitted to or carried on a motor vehicle or trailer and is intended for the storage of gas for either –

- (a) the propulsion of the motor vehicle; or
- (b) the operation of a gas-fired appliance;

“high pressure” means a pressure exceeding 1.0325 bar absolute;

“high pressure pipeline” means a pipeline intended to contain gas at high pressure;

“pipeline” means any pipe or passage connecting any 2 parts of a gas propulsion system of a vehicle or of a gas-fired appliance supply system on a vehicle or any 2 points on the same part of any such system;

“portable gas container” means a gas container which may be attached to a vehicle but which can readily be removed;

“pressure relief valve” means a device which opens automatically when the pressure in the part of the gas system to which it is fitted exceeds a set value, reaches its maximum flow capacity when the set value is exceeded by 10% and closes automatically when the pressure falls below a set value; and

“reducing valve” means a device which automatically reduces the pressure of the gas passing through it, and includes regulator devices.

2 Gas containers

- (1) Every gas container shall –
 - (a) be capable of withstanding the pressure of the gas which may be stored in the container at the highest temperature which the gas is likely to reach;
 - (b) if fitted inside the vehicle be so arranged as to prevent so far as is practicable the possibility of gas entering the engine, passenger or living compartments due to leaks or venting from the container or valves, connections and gauges immediately adjacent to it, and the space containing these components shall be so ventilated and drained as to prevent the accumulation of gas;
 - (c) be securely attached to the vehicle in such a manner as not to be liable to displacement or damage due to vibration or other cause; and
 - (d) be so placed and so insulated or shielded as not to suffer any adverse effect from the heat of the exhaust system of any engine or any other source of heat.
- (2) Every portable gas container shall be either –
 - (a) hermetically sealed; or
 - (b) fitted with a valve or cock to enable the flow of gas from the container to be stopped.
- (3) Every fixed gas container shall –
 - (a) be fitted with –
 - (i) at least one pressure relief valve, and
 - (ii) at least one manually operated valve which may be extended by an internal dip tube inside the gas container so as to indicate when the container has been filled to the level corresponding to the filling ratio specified in the British Standards Institution Specification for Filling Ratios and Developed Pressure for Liquefiable and Permanent Gases (as defined, respectively, in paragraphs 3.2 and 3.5 of the said Specification) published in May 1976 under the number BS 5355; and
 - (b) be conspicuously and permanently marked with its design pressure.
- (4) If any fixed gas container is required to be fitted in a particular attitude or location, or if any device referred to in sub-paragraph (3) requires the container to be fitted in such a manner, then it shall be conspicuously and permanently marked to indicate that requirement.
- (5) If the operation of any pressure relief valve or other device referred to in sub-paragraph (3) may cause gas to be released from the gas container, an outlet shall be provided to lead such gas to the outside of the vehicle so as not to suffer any adverse effect from the heat of the exhaust system of any engine or any other source of heat, and that outlet from the pressure relief valve shall not be fitted with any other valve or cock.

3 Filling systems for fixed gas containers

- (1) Every connection for filling a fixed gas container shall be on the outside of the vehicle.

- (2) There shall be fitted to every fixed gas container either –
 - (a) a manually operated shut-off valve and an excess flow valve;
 - (b) a manually operated shut-off valve and a single check valve; or
 - (c) a double-check valve,and all parts of these valves in contact with gas shall be made entirely of suitable metal except that they may contain non-metal washers and seals provided that such washers and seals are supported and constrained by metal components.
- (3) In every case where a pipe is attached to a gas container for the purpose of filling the gas container there shall be fitted to the end of the pipe furthest from the gas container a check valve or a double-check valve.
- (4) There shall be fitted over every gas filling point on a vehicle a cap which shall –
 - (a) prevent any leakage of gas from the gas filling point;
 - (b) be secured to the vehicle by a chain or some other suitable means;
 - (c) be made of suitable material; and
 - (d) be fastened to the gas filling point by either a screw thread or other suitable means.

4 Pipelines

- (1) Every pipeline shall be fixed in such a manner and position that –
 - (a) it will not be adversely affected by the heat of the exhaust system of any engine or any other source of heat;
 - (b) it is protected from vibration and strain in excess of that which it can reasonably be expected to withstand; and
 - (c) in the case of a high pressure pipeline it is so far as is practicable accessible for inspection.
- (2) Save as provided in sub-paragraph (4), every high pressure pipeline shall be –
 - (a) a rigid line of steel, copper or copper alloy of high pressure hydraulic grade, suitable for service on road vehicles and designed for a minimum service pressure rating of not less than 75 bar absolute; and
 - (b) effectively protected against, or shielded from, or treated so as to be resistant to, external corrosion throughout its length unless it is made from material which is corrosion resistant under the conditions which it is likely to encounter in service.
- (3) No unsupported length of any high pressure pipeline shall exceed 600 mm.
- (4) Flexible hose may be used in a high pressure pipeline if –
 - (a) it is reinforced either by stainless steel wire braid or by textile braid;
 - (b) its length does not exceed 500 mm; and
 - (c) save in the case of a pipeline attached to a gas container for the purpose of filling that container the flexibility which it provides is necessary for the construction or operation of the gas system of which it forms a part.

- (5) If a high pressure pipeline or part of such a pipeline is so constructed or located that it may, in the course of its normal use (excluding the supply of fuel from a gas container) contain liquid which is prevented from flowing, a relief valve shall be incorporated in that pipeline.

5 Unions and joints

- (1) Every union and joint on a pipeline or gas container shall be so constructed and fitted that it will –
- (a) not be liable to work loose or leak when in use; and
 - (b) be readily accessible for inspection and maintenance.
- (2) Every union on a high pressure pipeline or on a gas container shall be made of suitable metal but such a union may contain non-metal washers and seals provided that such washers and seals are supported and constrained by metal components.

6 Reducing valves

Every reducing valve shall be made of suitable materials and be so fitted as to be readily accessible for inspection and maintenance.

7 Pressure relief valves

- (1) Every pressure relief valve which is fitted to any part of a gas system (including a gas container) shall –
- (a) be made entirely of suitable metal and so constructed and fitted as to ensure that the cooling effect of the gas during discharge shall not prevent its effective operation;
 - (b) be capable, under the most extreme temperatures likely to be met (including exposure to fire), of a discharge rate which prevents the pressure of the contents of the gas system from exceeding its design pressure;
 - (c) have a maximum discharge pressure not greater than the design pressure of the gas container;
 - (d) be so designed and constructed as to prevent unauthorized interference with the relief pressure setting during service; and
 - (e) have outlets which are –
 - (i) so sited that so far as is reasonably practicable in the event of an accident the valve and its outlets are protected from damage and the free discharge from such outlets is not impaired, and
 - (ii) so designed and constructed as to prevent the collection of moisture and other foreign matter which could adversely affect their performance.
- (2) The pressure at which a pressure relief valve is designed to start lifting shall be clearly and permanently marked on every such valve.
- (3) Every pressure relief valve which is fitted to a gas container shall communicate with the vapour space in the gas container and not with any liquefied gas.

8 Valves and cocks

- (1) A valve or cock shall be fitted to every supply pipeline as near as practicable to every fixed gas container and such valve or cock shall by manual operation enable the supply of gas from the gas container to the gas system to be stopped, and save as provided in sub-paragraph (2), shall –
 - (a) if fitted on the outside of the vehicle, be readily visible and accessible from the outside of the vehicle; or
 - (b) if fitted inside the vehicle be readily accessible for operation and be so arranged as to prevent so far as is practicable the possibility of gas entering the engine, passenger or living compartments due to leaks, and the space containing the valve or cock shall be so ventilated and drained as to prevent the accumulation of gas in that space.
- (2) Where a fixed gas container supplies no gas system other than a gas propulsion system and the gas container is so located that it is not practicable to make the valve or cock referred to in sub-paragraph (1) readily accessible there shall be fitted an electrically-operated valve which shall either be incorporated in the valve or cock referred to in sub-paragraph (1) or be fitted immediately downstream from it and shall –
 - (a) be constructed so as to open when the electric power is applied and to close when the electric power is cut off;
 - (b) be so fitted as to shut off the supply of gas from the gas container to the gas system when the engine is not running; and
 - (c) if fitted inside the vehicle be so arranged as to prevent as far as is practicable the possibility of gas entering the engine, passenger or living compartments due to leaks, and the space containing the valve shall be so ventilated and drained as to prevent the accumulation of gas in that space.
- (3) A notice clearly indicating the position, purpose and method of operating every valve or cock referred to in sub-paragraphs (1) and (2) shall be fixed –
 - (a) in all cases, in a conspicuous position on the outside of the vehicle; and
 - (b) in every case where the valve or cock is located inside the vehicle, in a conspicuous position adjacent to the gas container.
- (4) In the case of a high pressure pipeline for the conveyance of gas from the gas container an excess flow valve shall be fitted as near as practicable to the gas container and such valve shall operate in the event of a fracture of the pipeline or other similar failure.
- (5) All parts of every valve or cock referred to in this paragraph which are in contact with gas shall be made of suitable metal, save that they may contain non-metal washers and seals provided that such washers and seals are supported and constrained by metal components.

9 Gauges

Every gauge connected to a gas container or to a pipeline shall be so constructed as to be unlikely to deteriorate under the action of the gas used or to be used and shall be so constructed and fitted that –

- (a) no gas can escape into any part of the vehicle as a result of any failure of the gauge; and
- (b) in the event of any failure of the gauge the supply of the gas to the gauge can be readily stopped:

Provided that the requirement specified in sub-paragraph (b) shall not apply in respect of a gauge fitted as an integral part of a gas container.

10 Propulsion systems

- (1) Every gas propulsion system shall be so designed and constructed that –
 - (a) the supply of gas to the engine is automatically stopped by the operation of a valve when the engine is not running at all or is not on the supply of gas; and
 - (b) where a reducing valve is relied on to comply with sub-paragraph (a), the supply of gas to the engine is automatically stopped by the operation of an additional valve where the engine is switched off.
- (2) Where the engine of a vehicle is constructed or adapted to run on one or more fuels as alternatives to gas, the safety and efficiency of the engine and any fuel system shall not be impaired by the presence of any other fuel system.

11 Special requirements for buses

In the case of a bus there shall be fitted as near as practicable to the gas container a valve which shall stop the flow of gas into the gas supply pipeline in the event of –

- (a) the angle of tilt of the vehicle exceeding that referred to in regulation 6 of the Public Service Vehicles (Conditions of Fitness, Equipment, Use and Certification) Regulations 1981 of the United Kingdom; and
- (b) the deceleration of the vehicle exceeding 5 g.

12 Gas-fired appliances

Every part of a gas-fired appliance shall be –

- (a) so designed and constructed that leakage of gas is unlikely to occur; and
- (b) constructed of materials which are compatible both with each other and with the gas used.

13

Every gas-fired appliance shall be –

- (a) so located as to be easily inspected and maintained;
- (b) so located and either insulated or shielded that its use shall not cause or be likely to cause danger due to the presence of any flammable material;
- (c) so constructed and located as not to impose undue stress on any pipe or fitting; and
- (d) so fastened or located as not to work loose or move in relation to the vehicle.

14

With the exception of catalytic heating appliances, every appliance of the kind described in Article 102(3)(b) or (c) which is fitted to a motor vehicle shall be fitted with a flue which shall be –

- (a) connected to an outlet which is on the outside of the vehicle;
- (b) constructed and located so as to prevent any expelled matter from entering the vehicle; and
- (c) located so that it will not cause any adverse effect to, or suffer any adverse effect from, the exhaust outlet of any engine or any other source of heat.

15 General requirements

Every part of a gas propulsion system or a gas-fired appliance system, excluding the appliance itself, shall be –

- (a) so far as is practicable so located or protected as not to be exposed to accidental damage;
- (b) soundly and properly constructed of materials which are compatible with one another and with the gas used or to be used and which are capable of withstanding the loads and stresses likely to be met in operation; and
- (c) so designed and constructed that leakage of gas is unlikely to occur.

SCHEDULE 6

(Article 43)

CONSTRUCTION OF MINIBUSES

The requirements referred to in Article 43 are as follows –

1 Exhaust pipes

The outlet of every exhaust pipe fitted to a minibus shall be either at the rear or on the offside of the vehicle.

2 Doors – number and position

- (1) Every minibus shall be fitted with at least –
 - (a) one service door on the near side of the vehicle; and
 - (b) one emergency door either at the rear or on the offside of the vehicle so, however, that any emergency door fitted on the offside of the vehicle shall be in addition to the driver's door and there shall be no requirement for an emergency door on a minibus if it has a service door at the rear in addition to the service door on the near side.
- (2) No minibus shall be fitted with any door on its offside other than a driver's door and an emergency door.

3 Emergency doors

Every emergency door fitted to a minibus, whether or not required pursuant to this Order, shall –

- (a) be clearly marked, in letters not less than 25 mm high, on both the inside and the outside, "EMERGENCY DOOR" or "FOR EMERGENCY USE ONLY", and the means of its operation shall be clearly indicated on or near the door;
- (b) if hinged, open outwards;
- (c) be capable of being operated manually; and
- (d) when fully opened, give an aperture in the body of the vehicle not less than 1210 mm high nor less than 530 mm wide.

4 Power-operated doors

- (1) Every power-operated door fitted to a minibus shall –
 - (a) incorporate transparent panels so as to enable a person immediately inside the door to see any person immediately outside the door;

- (b) be capable of being operated by a mechanism controlled by the driver of the vehicle when in the driving seat;
 - (c) be capable, in the event of an emergency or a failure of the supply of power for the operation of the door, of being opened from both inside and outside the vehicle by controls which –
 - (i) over-ride all other controls,
 - (ii) are placed on, or adjacent to, the door, and
 - (iii) are accompanied by markings which clearly indicate their position and method of operation and state that they may not be used by passengers except in an emergency;
 - (d) have a soft edge so that a trapped finger is unlikely to be injured; and
 - (e) be controlled by a mechanism by virtue of which if the door when closing, meets a resistance exceeding 150 Newtons, either –
 - (i) the door will cease to close and begin to open, or
 - (ii) the closing force will cease and the door will become capable of being opened manually.
- (2) No minibus shall be equipped with a system for the storage or transmission of energy in respect of the opening or closing of any door which, either in normal operation or if the system fails, is capable of adversely affecting the operation of the vehicle's braking system.

5 Locks, handles and hinges of doors

No minibus shall be fitted with –

- (a) a door which can be locked from the outside unless, when so locked, it is capable of being opened from inside the vehicle when stationary;
- (b) a handle or other device for opening any door, other than the driver's door, from inside the vehicle unless the handle or other device is designed so as to prevent, so far as is reasonably practicable, the accidental opening of the door, and is fitted with a guard or transparent cover or so designed that it must be raised to open the door;
- (c) a door which is not capable of being opened, when not locked, from inside and outside the vehicle by a single movement of the handle or other device for opening the door;
- (d) a door in respect of which there is not a device capable of holding the door closed so as to prevent any passenger falling through the doorway;
- (e) a side door which opens outwards and is hinged at the edge nearest the rear of the vehicle except in the case of a door having more than one rigid panel;
- (f) a door, other than a power-operated door, in respect of which there is not either –
 - (i) a slam lock of the 2-stage type, or
 - (ii) a device by means of which the driver, when occupying the driver's seat, is informed if the door is not securely closed, such device being operated by movement of the handle or other device for opening the

door or, in the case of a handle or other device with a spring-return mechanism, by movement of the door as well as of the handle or other device:

Provided that the provisions of sub-paragraphs (a), (c), (d) and (f) shall not apply in respect of a rear side door forming part of a pair of doors fitted at the rear of a vehicle if that door is capable of being held securely closed by the other door of that pair.

6 View of doors

- (1) Save as provided in sub-paragraph (2), every minibus shall be fitted with mirrors or other means so that the driver, when occupying the driver's seat, can see clearly the area immediately inside and outside every service door of the vehicle.
- (2) The provisions of sub-paragraph (1) shall be deemed to be satisfied in respect of a rear service door if a person 1.3 metres tall standing 1 metre behind the vehicle is visible to the driver when occupying the driver's seat.

7 Access to doors

- (1) Save as provided in sub-paragraph (2), there shall be unobstructed access from every passenger seat in a minibus to at least 2 doors one of which must be on the nearside of the vehicle and one of which must be either at the rear or on the offside of the vehicle.
- (2) Access to one only of the doors referred to in sub-paragraph (1) may be obstructed by either or both –
 - (a) a seat which when tilted or folded does not obstruct access to that door; and
 - (b) a lifting platform or ramp which –
 - (i) does not obstruct the handle or other device on the inside for opening the door with which the platform or ramp is associated, and
 - (ii) when the door is open, can be pushed or pulled out of the way from the inside so as to leave the doorway clear for use in an emergency.

8 Grab handles and hand rails

Every minibus shall be fitted as respects every side service door with a grab handle or a hand rail to assist passengers to get on or off the vehicle.

9 Seats

- (1) No seat shall be fitted to any door of a minibus.
- (2) Every seat and every wheelchair anchorage fitted to a minibus shall be fixed to the vehicle.
- (3) No seat, other than a wheelchair, fitted to a minibus shall be less than 400 mm wide, and in ascertaining the width of a seat no account shall be taken of any arm-rests, whether or not they are folded back or otherwise put out of use.
- (4) No minibus shall be fitted with an anchorage for a wheelchair in such a manner that a wheelchair secured to the anchorage would face either side of the vehicle.

- (5) No minibus shall be fitted with a seat –
- (a) facing either side of the vehicle and immediately forward of a rear door unless the seat is fitted with an arm-rest or similar device to guard against a passenger on that seat falling through the doorway; or
 - (b) so placed that a passenger on it would, without protection, be liable to be thrown through any doorway which is provided with a power-operated door or down any steps, unless the vehicle is fitted with a screen or guard which affords adequate protection against that occurrence.

10 Electrical equipment and wiring

- (1) Save as provided in sub-paragraph (2) no minibus shall be fitted with any –
- (a) electrical circuit which is liable to carry a current exceeding that for which it was designed;
 - (b) cable for the conduct of electricity unless it is suitably insulated and protected from damage;
 - (c) electrical circuit, other than a charging circuit, which includes any equipment other than –
 - (i) a starter motor,
 - (ii) a glow plug,
 - (iii) an ignition circuit, and
 - (iv) a device to stop the vehicle's engine,unless it includes a fuse or circuit breaker so, however, that one fuse or circuit breaker may serve more than one circuit; or
 - (d) electrical circuit with a voltage exceeding 100 volts unless there is connected in each pole of the main supply of electricity which is not connected to earth a manually-operated switch which is –
 - (i) capable of disconnecting the circuit, or, if there is more than one, every circuit, from the main supply,
 - (ii) not capable of disconnecting any circuit supplying any lamp with which the vehicle is required to be fitted, and
 - (iii) located inside the vehicle in a position readily accessible to the driver.
- (2) The provisions of sub-paragraph (1) do not apply in respect of a high tension ignition circuit or a circuit within a unit of equipment.

11 Fuel tanks

No minibus shall be fitted with a fuel tank or any apparatus for the supply of fuel which is in the compartments or other spaces provided for the accommodation of the driver or passengers.

12 Lighting of steps

Every minibus shall be provided with lamps to illuminate every step at a passenger exit or in a gangway.

13 General construction and maintenance

Every minibus, including all bodywork and fittings, shall be soundly and properly constructed of suitable materials and maintained in good and serviceable condition, and shall be of such design as to be capable of withstanding the loads and stresses likely to be met in the normal operation of the vehicle.

14 Definitions

In this Schedule –

“driver’s door” means a door fitted to a minibus for use by the driver;

“emergency door” means a door fitted to a minibus for use by passengers in an emergency; and

“service door” means a door fitted to a minibus for use by passengers in normal circumstances.

SCHEDULE 7

FIRE EXTINGUISHING APPARATUS AND FIRST AID EQUIPMENT FOR MINIBUSES

PART 1

(Article 44)

Fire extinguishing apparatus

A fire extinguisher which complies in all respects with the specification for portable fire extinguishers issued by the British Standards Institution numbered BS 5423: 1977 or BS 5423: 1980 or BS 5423: 1987 and which –

- (a) has a minimum test fire rating of 8A or 21B; and
- (b) contains water or foam or contains, and is marked to indicate that it contains, halon 1211, or halon 1301.

PART 2

(Article 45)

First aid equipment

- (i) 10 antiseptic wipes, foil packed,
- (ii) one conforming disposable bandage (not less than 7.5 cm wide),
- (iii) 2 triangular bandages,
- (iv) one packet of 24 assorted adhesive dressings,
- (v) 3 large sterile unmedicated ambulance dressings not less than 15.0 cm x 20.0 cm),
- (vi) 2 sterile eye pads, with attachments,
- (vii) 12 assorted safety pins, and
- (viii) one pair of rustless blunt-ended scissors.

SCHEDULE 8

(Articles 62, 63 and 64)

MOTOR CYCLE NOISE AND MOTOR CYCLE SILENCERS**PART 1****1.**

- (1) For the purposes of this Order a vehicle meets the requirements of an item in the Table if its sound level does not exceed by more than 1dB(A) the relevant limit specified in column 2 in that item when measured under the conditions specified in column 3 in that item by the method specified in column 4 in that item using the apparatus prescribed in Article 60.
- (2) In this Part, “moped” has the same meaning as in Article 62.

TABLE

1	2		3	4
	Limits of sound level			
<i>Item</i>	<i>Mopeds</i>	<i>Vehicles other than mopeds</i>	<i>Conditions of measurement</i>	<i>Methods of measurement</i>
1	73 dB(A)	Limit determined in accordance with paragraph 2.1.1 of Annex I to Community Directive 78/1015 by reference to the cubic capacity of the vehicle	Conditions specified in paragraph 2.1.3 of Annex I to Community Directive 78/1015	Methods specified in paragraph 2.1.4 of Annex I to Community Directive 78/1015
2	73 dB(A)	First stage limit determined in accordance with paragraph 2.1.1 of Annex I to Community Directive 87/56 by reference to the cubic capacity of the vehicle	Conditions specified in paragraph 2.1.3 of Annex I to Community Directive 87/56	Methods specified in paragraph 2.1.4 of Annex I to Community Directive 87/56
3	74 dB(A)	The limit specified in item 2 plus 1 dB(A)	As in item 2	As in item 2

PART 2

2. The requirements of this paragraph are that the silencer –
 - (a) is so constructed that –
 - (i) it meets the requirements of paragraphs 3 and 4 of British Standards BS AU 193: 1983,
 - (ii) were it to be fitted to an unused vehicle of the same model as the vehicle in question, the unused vehicle would meet the requirements of paragraph 5.2 of that Standard; and
 - (b) is clearly and indelibly marked “BS AU 193/T2”.
3. The requirements of this paragraph are that the silencer –
 - (a) is so constructed that –
 - (i) it meets the requirements of paragraphs 3 and 4 of British Standard BS AU 193a: 1990;
 - (ii) were it to be fitted to an unused vehicle of the same model as the vehicle in question the unused vehicle would meet the requirements of paragraph 5.2 of that Standard; and
 - (b) is clearly and indelibly marked “BS AU 193a: 1990/T2”.
4. The requirements of this paragraph are that the silencer –
 - (a) is so constructed that –
 - (i) it meets the requirements of paragraphs 3 and 4 of British Standard BS AU 193a: 1990,
 - (ii) were it to be fitted to an unused vehicle of the same model as the vehicle in question the unused vehicle would meet the requirements of paragraph 5.3 of that Standard; and
 - (b) is clearly and indelibly marked “BS AU 193a: 1990/T3”.
5. In this Part –
 - (a) “British Standard BS AU 193: 1983” means the British Standard Specification for replacement motor cycle and moped exhaust systems published by the British Standards Institution under reference number BS AU 193: 1983;
 - (b) “British Standard BS AU 193a: 1990” means the British Standard Specification for replacement motor cycle and moped exhaust systems published by the British Standards Institution under reference number BS AU 193a: 1990.

PART 3

6. Article 63(4) shall not apply to a replacement silencer if the second requirement referred to in that Article would be met were there substituted in Part 2 –

- (a) for the references to provisions in either of the British Standard Specifications, references to equivalent provisions in a corresponding standard; and
 - (b) for the references to a mark, references to a mark made pursuant to that corresponding standard indicating that the silencer complies with those equivalent provisions.
7. In this Part “corresponding standard”, in relation to a British Standard Specification, means –
- (a) a standard or code of practice of a national standards body or equivalent body of any member State;
 - (b) any international standard recognized for use as a standard by any member State; or
 - (c) a technical specification or code of practice which, whether mandatory or not, is recognized for use as a standard by a public authority of any member State,
- where the standard code of practice, international standard or technical specification provides, in relation to motor cycles, a level of noise limitation and safety equivalent to that provided by the British Standard Specification and contains a requirement as respects the marking of silencers equivalent to that provided by that instrument.
8. A reference in this Part to a British Standard Specification is a reference to British Standard BS AU 193: 1983 or British Standard BS AU 193a: 1990; and “either of the British Standard Specifications” shall be construed accordingly.
9. In this Part, “British Standard BS AU 193: 1983” and “British Standard BS AU 193a: 1990” have the same meaning as in Part 2.

SCHEDULE 9

(Article 68(23), (24) and (27))

EMISSIONS FROM CERTAIN MOTOR VEHICLES

PART 1

Vehicles propelled by spark ignition engines

1. This Part applies to a vehicle if, when the engine is running without load at a normal idling speed, the carbon monoxide content of the exhaust emissions from the engine exceeds the relevant percentage of the total exhaust emissions from the engine by volume.
2. This Part also applies to a vehicle if, when the engine is running without load at a fast idling speed –
 - (a) the carbon monoxide content of the exhaust emissions from the engine exceeds 0.3% of the total exhaust emissions from the engine by volume;
 - (b) the hydrocarbon content of those emissions exceeds 0.02% of the total exhaust emissions from the engine by volume; or
 - (c) the lambda value is not within the relevant limits.
3. For the purposes of this Part the relevant percentage, in respect of a vehicle, is –
 - (a) if the vehicle is of a description specified in the Annex to the emissions publication, the percentage shown against that description of vehicle in column 2(a) of that Annex; or
 - (b) if the vehicle is not of such a description, 0.5%.
4. For the purposes of this Part, in the case of a vehicle of a description specified in the Annex to the emissions publication, the engine shall be regarded as running at a normal idling speed if and only if the engine is running at a rotational speed between the minimum and maximum limits shown against that description of vehicle in columns 2(b) and (c) respectively of that Annex.
5. For the purposes of this Part an engine shall be regarded as running at a fast idling speed if –
 - (a) the vehicle is of a description specified in the Annex to the emissions publication and the engine is running at a rotational speed between the minimum and maximum limits shown against that description of vehicle in columns 3(e) and (f) respectively of that Annex; or
 - (b) the vehicle is not of such a description and the engine is running at a rotational speed between 2,500 and 3,000 revolutions per minute.
6. For the purposes of this Part, the lambda value, in respect of a vehicle, shall be regarded as being within relevant limits, if and only if –

- (a) the vehicle is of a description specified in the Annex to the emissions publication and the lambda value is between the minimum and maximum limits shown against that description of vehicle in column 3(c) and (d) respectively of that Annex; or
 - (b) the vehicle is not of such a description and the lambda value is between 0.97 and 1.03.
7. In this Part –
- (a) a reference to the lambda value, in relation to a vehicle at any particular time is a reference to the ratio by mass of air to petrol vapour in the mixture entering the combustion chambers divided by 14.7; and
 - (b) “the emissions publication” is the publication entitled “In-Service Exhaust Emissions Standards for Road Vehicles – Second Edition” (ISBN 0 – 952647 – 1 – 8) published by the Department of Transport of the United Kingdom.

PART 2

Vehicles propelled by compression ignition engines

8. This Part applies to a vehicle if with free acceleration, the coefficient of absorption of the exhaust emissions from the engine immediately after leaving the exhaust system exceeds –
- (a) if the engine of the vehicle is turbo-charged, 3.0 per metre; or
 - (b) in any other case, 2.5 per metre.
9. In this Part –
- (a) “coefficient of absorption” shall be construed in accordance with paragraph 3.5 of Annex VII to Community Directive 72/306; and
 - (b) “free acceleration” has the same meaning as in Annex II to Council Directive 77/143/EEC as amended by Council Directive 884/449/EEC, Council Directive 91/225/EEC, Council Directive 91/328 and Council Directive 92/55.

SCHEDULE 10

(Article 73)

PLATES FOR CERTAIN VEHICLES

PART 1

Particulars to be shown on plate for motor vehicles (including motor vehicles forming part of articulated vehicles).

1. Manufacturer's name.
 2. Vehicle type.
 3. Engine type and power (a).
 4. Chassis or serial number.
 5. Number of axles.
 6. Maximum axle weight for each axle (b).
 7. Maximum gross weight (c).
 8. Maximum train weight (d).
- (a) The power need not be shown in the case of a motor vehicle manufactured before 1st October 1972 (in this Schedule referred to as "an excepted vehicle") and shall not be shown in the case of any motor vehicle which is propelled otherwise than by a compression ignition engine.
- (b) This weight as respects each axle is the sum of the weights to be transmitted to the road surface by all the wheels of that axle.
- (c) This weight is the sum of the weights to be transmitted to the road surface by all the wheels of the motor vehicle (including any load imposed by a trailer, whether forming part of an articulated vehicle or not, on the motor vehicle).
- (d) This weight is the sum of the weights to be transmitted to the road surface by all the wheels of the motor vehicle and of any trailer drawn, but this item need not be completed where the motor vehicle is not constructed to draw a trailer.
- (b), (c), (d) References to the weights to be transmitted to the road surface by all or any of the wheels of the vehicle or of any trailer drawn are references to the weights so to be transmitted both of the vehicle or trailer and of any load or person carried by it.

PART 2

Particulars to be shown on plate for trailers (including trailers forming part of articulated vehicles).

1. Manufacturer's name.
 2. Chassis or serial number.
 3. Number of axles.
 4. Maximum weight for each axle (a).
 5. Maximum load imposed on drawing vehicle (b).
 6. Maximum gross weight (c).
 7. Year of manufacture (d).
- (a) This weight as respects each axle is the sum of the weights to be transmitted to the road surface by all the wheels of that axle.
- (b) Only for trailers forming part of articulated vehicles or where some of the weight of the trailer or its load is to be imposed on the drawing vehicle. This item need not be completed in the case of a converter dolly.
- (c) This weight is the sum of the weights to be transmitted to the road surface by all the wheels of the trailer, including any weight of the trailer to be imposed on the drawing vehicle.
- (a), (b), (c) References to the weights to be transmitted to the road surface by all or any of the wheels of the trailer are references to the weight so to be transmitted both of the trailer and of any load or persons carried by it and references to the weights to be imposed on the drawing vehicles are references to the weights so to be imposed both of the trailer and of any load or persons carried by it except where only the load of the trailer is imposed on the drawing vehicle.
- (d) This item need not be completed in the case of a trailer manufactured before 1st April 1970.

PART 3

1. The power of an engine, which is to be shown only in the case of a compression ignition engine on the plate in respect of item 3 in Part 1, shall be the amount in kilowatts equivalent to the installed power output shown in a type test certificate issued –
 - (a) by a person authorized by the Secretary of State for Transport of the United Kingdom for the type of engine to which the engine conforms; and
 - (b) in accordance with either –
 - (i) the provisions relating to the installed brake power output specified in the British Standard Specification for the Performance of Diesel Engines for Road Vehicles published on 19th May 1971 under the number BS AU 141a: 1971,
 - (ii) the provisions relating to the net power specified in Community Directive 80/1269 but after allowance has been made for the power absorbed by such equipment, at its minimum power setting, driven by the engine of the vehicle as is fitted for the operation of the vehicle (other than its propulsion) such power being measured at the speed

corresponding to the engine speed at which maximum engine power is developed, or

- (iii) the provisions of Annex 10 of ECE Regulation 24.02 as further amended with effect from 15th February 1984 or Annex 10 of ECE Regulation 24.03 or Community Directive 88/195 relating to the method of measuring internal combustion engine net power, but after allowance has been made for the power absorbed by any disconnectable or progressive cooling fan, at its maximum setting, and by any other such equipment, at its minimum power setting, driven by the engine of the vehicle as is fitted for the operation of the vehicle (other than its propulsion), such power being measured at the speed corresponding to the engine speed at which maximum engine power is developed.

2.

- (1) The weights to be shown on the plate in relation to items 6, 7 and 8 in Part 1 and in relation to items 4, 5 and 6 in Part 2 shall be the weight limits at or below which the vehicle is considered fit for use, having regard to its design, construction and equipment and the stresses to which it is likely to be subject in use, by the Secretary of State for Transport of the United Kingdom if the vehicle is one to which the Type Approval for Goods Vehicles Regulations apply, and by the manufacturer if the vehicle is one to which those Regulations do not apply:

Provided that, where alterations are made to a vehicle which may render the vehicle fit for use at weights which exceed those referred to in this paragraph and shown on the plate –

- (a) there may be shown on the plate, in place of any of those weights, such new weights as the manufacturer of the vehicle or any person carrying on business as a manufacturer of motor vehicles or trailers (or a person duly authorized on behalf of that manufacturer or any such person) (that person being also authorized by the Inspector of Motor Traffic) considers to represent the weight limits at or below which the vehicle will then be fit for use, having regard to its design, construction and equipment and to those alterations and to the stresses to which it is likely to be subject in use; and
 - (b) the name of the person who has determined the new weights shall be shown on the plate as having made that determination and, where the person is a person authorized by the Inspector of Motor Traffic, the person's appointment shall be so shown.
- (2) In relation to a vehicle manufactured on or after 1st October 1972 in sub-paragraph (1) –
 - (a) the references to equipment shall not be treated as including a reference to the type of tyres with which the vehicle is equipped; and
 - (b) for the words “weight limits at or below” in both places where they occur there shall be substituted the words “maximum weights at”.

3.

- (1) Subject to sub-paragraph (2), weights on plates first affixed to a vehicle on or after 1st October 1972 shall be shown in kilograms and weights on plates first so affixed before that date shall be shown in tons and decimals thereof.

-
- (2) Where a new weight is first shown on a plate additional to that required in Parts 1 or 2 by virtue of the proviso to paragraph 2(1) the weight shall be shown as if it was on a plate first affixed to a vehicle on the date it was first shown.
- 4.** All letters and figures shown on that plate shall be not less than 6 mm in height.
- 5.** In this Schedule references to the manufacturer of a motor vehicle or trailer are in relation to –
- (a) a vehicle constructed with a chassis which has not previously formed part of another vehicle, references to the person by whom that chassis was made;
 - (b) any other vehicle, references to the person by whom that vehicle was constructed.

SCHEDULE 11

(Article 76)

Plates for motor cycles and mopeds

1. The plate required by Article 76 shall be firmly attached to a part of the motor cycle which is not normally subject to replacement during the life of the motor cycle.
2. The plate shall be in the form shown in the diagram in this paragraph, shall have dimensions not less than those shown in that diagram and shall show the information provided for in that diagram and detailed in the Notes to the diagram.

Diagram of Plate

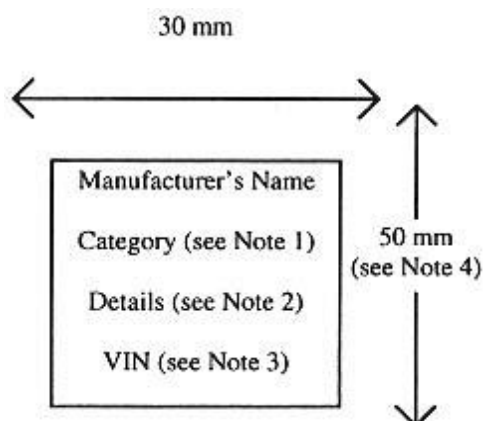

Notes:

1. The categories are “standard motor cycle” and “moped”.
2. The details are –
 - (a) for standard motor cycles –
 - (i) the engine capacity,
 - (ii) the maximum engine power, and
 - (iii) the power to weight ratio,
 provided that the details under (ii) and (iii) need not be shown for a vehicle first used before 1st January 1982;
 - (b) for mopeds –
 - (i) the engine capacity,
 - (ii) the kerbside weight, and
 - (iii) the maximum speed.
3. The vehicle identification number (VIN) shall be marked in the form used by the manufacturer to identify any one individual vehicle.

4. In the case of a plate fitted to a vehicle first used before 1st January 1982 or to a moped this dimension shall be 40 mm.
3. The information on the plate shall be shown in characters not less than 4 mm in height and in the positions on the plate indicated in the diagram.
4. No information, other than that provided in the diagram shall be marked within the rectangle which is shown in the diagram.
5. In this Schedule and, in respect of the definition of “moped”, in Article 1(1) –
“diagram” means the diagram in this Schedule;
“maximum engine power” means the maximum net power the motor cycle engine will develop, in kilowatts, when measured in accordance with the test conditions specified in the International Standard number ISO 4106 developed by the technical committee of the International Organization for Standardisation, and approved by member bodies, including the United Kingdom, and published under the reference ISO 1978 4106 – 09 – 01;
“moped” means a motor cycle which –
 - (a) has a kerbside weight not exceeding 250 kg; and
 - (b) if propelled by an internal combustion engine, has an engine with a cylinder capacity which does not exceed 50 cc; and
 - (c) is designed to have a maximum speed not exceeding 30 mph when driven under the conditions set out in paragraph 6;“power to weight ratio” means the ratio of the maximum engine power to the kerbside weight of the vehicle measured, as regards the maximum engine power, in kilowatts and, as regards the kerbside weight, in 1,000 kg;
“standard motor cycle” means a motor cycle which is not a moped.
6. A motor cycle shall be regarded as complying with paragraph (c) of the definition of “moped” in paragraph 5 if it cannot exceed 35 mph when tested under the following conditions –
 - (a) the surface on which it is tested shall be dry asphalt or concrete;
 - (b) the rider shall be a person not exceeding 75 kg in weight;
 - (c) no passenger or load shall be carried;
 - (d) the test route shall be so located that acceleration to, and deceleration from, maximum speed can take place elsewhere than on the test route itself;
 - (e) the test route shall not have a gradient exceeding 5%;
 - (f) the motor cycle shall be ridden in opposite directions along the test route and the speed recorded for the purpose of the test shall (in order to minimize the effect of wind resistance and gradient) be the average of speed shown for each direction;
 - (g) when being driven along the test route, the motor cycle shall be driven in such manner and in such gear as to achieve the maximum speed of which it is capable; and
 - (h) if the motor cycle is fitted with a device which can, without the use of specialist tools or equipment, be readily modified or removed so as to

increase its maximum speed, the test shall be carried out with the device in the modified condition or, as the case may be, without the device.

SCHEDULE 12

(Article 77)

DEPARTMENT PLATE

YEAR OF MANUFACTURE

UNLADEN WEIGHT

MAXIMUM GROSS WEIGHT

TRAIN WEIGHT

OVERALL WIDTH

OVERALL LENGTH

- (1) Figures must be –
 - (a) not less than 15 mm high;
 - (b) coloured black;
 - (c) set on a white background;
 - (d) of a stroke width of not less than 2 mm.
- (2) Plate must be not less than 15 cm by 15 cm.

SCHEDULE 13

(Articles 81, 83 and 85)

MAXIMUM PERMITTED WEIGHTS, ETC.**PART 1**

(Article 81)

Maximum permitted laden weights of trailers and heavy motor cars and motor cars not fitted with road friendly suspension; in each case not forming part of an articulated vehicle.

1. The maximum permitted laden weight of a 2 or 3 axle trailer vehicle to which this Part applies of a description specified in column 2 of Table 1 shall, for the purposes of Article 81, be the weight specified in column 3 of that item.
2. In the case of a vehicle to which this Part applies and which is not of a description specified in an item in column 2 of Table 1, the maximum permitted laden weight shall, for the purposes of Article 81, be the weight specified in column 4 of Table 2 in the item which is appropriate having regard to columns 2 and 3 of that Table.

TABLE 1

1	2	3
<i>Item</i>	<i>Description of vehicle</i>	<i>Maximum permitted laden weight (kg)</i>
1	A 2 axle motor vehicle which is a goods vehicle in which the distance between the foremost and rearmost axles is at least 3.0 m	17,000
2	A 2 axle trailer in which – (a) the 2 axles are closely spaced; and (b) the distance between the foremost axle of the trailer and the rearmost axle of the drawing vehicle is at least 4.2 m	18,000
3	A 2 axle trailer in which the distance between the foremost axle and the rearmost axle is at least 3.0 m	18,000
4	A 3 axle trailer in which – (a) the 3 axles are closely spaced; and (b) the distance between the foremost axle of the trailer and the rearmost axle of the drawing vehicle is at least 4.2 m	24,000

TABLE 2

Maximum permitted laden weights of vehicle not falling within Table 1

1	2	3	4
<i>Item</i>	<i>No. of axles</i>	<i>Distance between foremost and rearmost axles (metres)</i>	<i>Maximum permitted laden weight (kg)</i>
1	2	Less than 2.65	14,230
2	2	At least 2.65	16,260
3	3 or more	Less than 3.0	16,260
4	3 or more	At least 3.0 but less than 3.2	18,290
5	3 or more	At least 3.2 but less than 3.9	20,330
6	3 or more	At least 3.9 but less than 4.9	22,360
7	3	At least 4.9	25,000
8	4 or more	At least 4.9 but less than 5.6	25,000
9	4 or more	At least 5.6 but less than 5.9	26,420
10	4 or more	At least 4.9 but less than 6.3	28,450
11	4 or more	At least 6.3	30,000

PART 2

(Article 81)

Maximum permitted gross weights for heavy motor cars and motor cars if the driving axles are fitted with road friendly suspension etc. and in each case not forming part of an articulated vehicle.

1. Subject to paragraph 2, the maximum permitted gross weight of vehicle to which this Part applies shall, for the purposes of Article 81, be the weight shown in column 4 of the Table in the item which is appropriate, having regard to columns 2 and 3 in that Table.
2. In the case of a vehicle to which this Part applies being a 2 axle goods vehicle which has a distance between its axles of at least 3.0 m, the maximum permitted laden weight for the purposes of Article 81 shall be 17,000 kg.

TABLE

Maximum permitted laden weight

1	2	3	4
<i>Item</i>	<i>No. of axles</i>	<i>Distance between foremost and rearmost axles (metres)</i>	<i>Maximum permitted laden weight (kg)</i>
1	2	Less than 2.65	14,230
2	2	At least 2.65	16,260
3	3 or more	Less than 3.0	16,260
4	3 or more	At least 3.0 but less than 3.2	18,290
5	3 or more	At least 3.2 but less than 3.9	20,330
6	3 or more	At least 3.9 but less than 4.9	22,360
7	3 or more	At least 4.9 but less than 5.2	25,000
8	3	At least 5.2	26,000

1	2	3	4
<i>Item</i>	<i>No. of axles</i>	<i>Distance between foremost and rearmost axles (metres)</i>	<i>Maximum permitted laden weight (kg)</i>
9	4 or more	At least 5.2 but less than 6.4	The distance in metres between the foremost and rearmost axles multiplied by 5,000 rounded up to the next 10 kg
10	4 or more	At least 6.4	32,000

PART 3

(Article 81)

Maximum permitted laden weights for heavy motor cars and motor cars forming part of articulated vehicles

1	2	3	4	5
<i>Item</i>	<i>No. of axles</i>	<i>Distance between foremost and rearmost axles (metres)</i>	<i>Weight not exceeded by any axle not being the foremost or rearmost (kg)</i>	<i>Maximum permitted laden weight (kg)</i>
1	2	At least 2.0	---	14,230
2	2	At least 2.4	---	16,260
3	2	At least 2.7	---	17,000
4	3 or more	At least 3.0	8390	20,330
5	3 or more	At least 3.8	8640	22,360
6	3 or more	At least 4.0	10,500	22,500
7	3 or more	At least 4.3	9150	24,390
8	3 or more	At least 4.9	10,500	24,390

PART 4

(Article 83)

Maximum permitted laden weight of articulated vehicles

1	2		3
<i>Item</i>	<i>Relevant axle spacing (metres)</i>		<i>Maximum weight (kg)</i>
	(a) Where motor vehicle has 2 axles	(b) Where motor vehicle has more than 2 axles	
1	At least 2.0	At least 2.0	20,330
2	At least 2.2	At least 2.2	22,360
3	At least 2.6	At least 2.6	23,370
4	At least 2.9	At least 2.9	24,390

1	2		3
<i>Item</i>	<i>Relevant axle spacing (metres)</i>		<i>Maximum weight (kg)</i>
5	At least 3.2	At least 3.2	25,410
6	At least 3.5	At least 3.5	26,420
7	At least 3.8	At least 3.8	27,440
8	At least 4.1	At least 4.1	28,450
9	At least 4.4	At least 4.4	29,470
10	At least 4.7	At least 4.7	30,490
11	At least 5.0	At least 5.0	31,500
12	At least 5.3	At least 5.3	32,520
13	At least 5.5	At least 5.4	33,000
14	At least 5.8	At least 5.6	34,000
15	At least 6.2	At least 5.8	35,000
16	At least 6.5	At least 6.0	36,000
17	At least 6.7	At least 6.2	37,000
18	At least 6.9	At least 6.3	38,000

PART 5

(Article 83)

Maximum permitted laden weight of articulated vehicles

1	2	3
<i>Item</i>	<i>Type of articulated vehicle</i>	<i>Maximum weight (kg)</i>
1	Motor vehicle first used on or after 1st April 1973 and semi-trailer having a total of 5 or more axles	38,000
2	Motor vehicle with 2 axles first used on or after 1st April 1973 and semi-trailer with 2 axles while being used for international transport	35,000
3	Motor vehicle with 2 axles first used on or after 1st April 1973 in which – (a) every driving axle not being a steering axle is fitted with twin tyres; and (b) every driving axle is fitted with road friendly suspension; and a semi-trailer with 2 axles	35,000
4	Motor vehicle and semi-trailer having a total of 4 or more axles and not described in item 1, 2 or 3	32,520
5	Motor vehicle with 2 axles first used on or after 1st April 1973 in which – (a) every driving axle not being a steering axle is fitted with twin tyres; and (b) every driving axle is fitted with road friendly suspension; and a semi-trailer with 1 axle	26,000
6	Motor vehicle with 2 axles and a semi-trailer with 1 axle being a combination not described in item 5	25,000

PART 6

(Article 85)

Vehicles with 2 closely-spaced axles

1	2	3
<i>Item</i>	<i>Description of vehicle</i>	<i>Maximum permitted weight of the 2 closely-spaced axles (kg)</i>
1	A motor vehicle or trailer in which (in either case) the distance between the 2 closely-spaced axles is less than 1.3 metres	16,000
2	A vehicle being – (a) a motor vehicle in which the distance between the 2 closely-spaced axles is at least 1.3 m; or (b) a trailer in which that distance is at least 1.3 m and less than 1.5 m, not being a vehicle described in item 3 or 4	18,000
3	A motor vehicle in which the distance between the 2 closely-spaced axles is at least 1.3 m and – (a) every driving axle not being a steering axle is fitted with twin tyres; and (b) either every driving axle is fitted with road-friendly suspension or neither of the 2 closely-spaced axles has an axle weight exceeding 9,500 kg	19,000
4	A trailer in which – (a) the 2 closely-spaced axles are driven from the motor vehicle drawing the trailer and are fitted with twin tyres; and (b) either those axles are fitted with road-friendly suspension or neither of them has an axle weight exceeding 9,500 kg	19,000
5	A trailer in which the distance between the 2 closely-spaced axles is at least 1.5 m and less than 1.8 m	19,320
6	A trailer in which the distance between the 2 closely-spaced axles is at least 1.8 m	20,000

PART 7

(Article 85)

Vehicles with 3 closely-spaced axles

1	2	3
<i>Item</i>	<i>Description of vehicle</i>	<i>Maximum permitted weight of the 3 closely-spaced axles (kg)</i>
1	A vehicle in which the smallest distance between any 2 of the 3 closely-spaced axles is less than 1.3 m	21,000
2	A vehicle in which the smallest distance between any 2 of the 3 closely-spaced axles is at least 1.3 m and at least one of those axles does not have air suspension	22,500
3	A vehicle in which the smallest distance between any 2 of the 3 closely-spaced axles is at least 1.3 m and all 3 axles are fitted with air suspension	24,000

SCHEDULE 14

(Articles 87 and 88)

CONDITIONS TO BE COMPLIED WITH IN RELATION TO THE USE OF VEHICLES CARRYING WIDE OR LONG LOADS OR VEHICLES CARRYING LOADS OR HAVING FIXED APPLIANCES OR APPARATUS WHICH PROJECT

PART 1

1 Advance notice to highway authority

- (a) Before using on a road a vehicle to which this paragraph applies, the owner shall give notice of the intended use to the highway authority and the Connétable of the parish in which the owner proposes to use the vehicle. The notice shall be given so that it is received by the date after which there are at least 2 working days before the date on which the use of the vehicle is to begin, and shall include the following details –
- (i) time, date and route of the proposed journey,
 - (ii) in a case to which Article 5(14) applies, the overall length of the trailer,
 - (iii) in a case to which Article 88(2) applies, the overall length and width of the vehicle by which the load is carried and the width of the lateral projection or projecting of its load,
 - (iv) in a case to which Article 88(4)(a) applies, the overall length and width of each vehicle by which the load is carried, the length of any forward or rearward projection and, where the load rests on more than one vehicle, the distance between the vehicles,
 - (v) in a case to which Article 88(4)(b) applies, the overall length of the combination of vehicles and the length of any forward or rearward projection of the load, and
 - (vi) in a case to which Article 88(7) and (8) applies, the overall length of the vehicle and the length of any forward or rearward projection of the load or special appliance or apparatus.

The highway authority of each parish may –

- (i) accept a shorter period of notice or fewer details,
 - (ii) impose such conditions as they shall deem necessary;
- (b) the vehicle shall be used only in accordance with the details at (a) subject to any variation in the time, date or route which may be directed by –
- (i) the highway authority of each parish to the owner of the vehicle or vehicles, or

- (ii) a police or traffic officer to the driver in the interests of road safety or in order to avoid undue traffic congestion by halting the vehicle in a place on or adjacent to the road on which the vehicle is travelling.

2 Attendance

At least one person in addition to the person employed in driving a vehicle to which this paragraph applies shall be employed –

- (a) in attending to that vehicle and its load and any other vehicle drawn by that vehicle and the load carried on the vehicle so drawn; and
- (b) to give warning to the driver of the said vehicle and to any person of any danger likely to be caused to any such other person by reason of the presence of the said vehicle on the road:

Provided that, where 3 or more vehicles in respect of which the conditions in this paragraph are applicable are travelling together in convoy, it shall be a sufficient compliance with this paragraph if only the foremost and rearmost vehicles in the convoy are attended in the manner prescribed in this paragraph.

For the purposes of this paragraph when a vehicle is drawing a trailer –

- (i) any person employed in attending that vehicle or any such trailer shall be treated as being an attendant required by this paragraph so long as he is also employed to discharge the duties mentioned in this paragraph; and
- (ii) when another vehicle is used for the purposes of assisting in their propulsion on the road the person employed in driving that other vehicle shall not be treated as a person employed in attending to the first-mentioned vehicle or any vehicle drawn thereby.

3 Marking of longer projections

- (a) Every forward and rearward projection to which this paragraph applies shall be fitted with –
 - (i) an end marker, except in the case of a rearward projection which is fitted with a rear marking in accordance with the Lighting Order; and
 - (ii) where required by sub-paragraphs (c) and (d), 2 or more side markers; which shall be of the size, shape and colour described in Part 2;
- (b) the end marker shall be so fitted that –
 - (i) it is as near as is practicable in a transverse plane,
 - (ii) it is not more than 0.5 m from the extreme end of the projection,
 - (iii) the vertical distance between the lowest point of the marker and the road surface is not more than 2.5 m,
 - (iv) the horizontal distance between each marker and the end marker or, as the case may be, the rear marking carried in accordance with the Lighting Order does not exceed 1 m, and

- (v) each marker is clearly visible within a reasonable distance to a person using the road on that side of the projection;
- (c) where –
 - (i) a forward projection exceeds 4.5 m, or
 - (ii) a rearward projection exceeds 5 m,

extra side markers shall be fitted on either side of the projection so that the horizontal distance between the extreme projecting point of the vehicle from which the projection extends and the nearest point on any marker from that point, and between the nearest points of any adjacent side markers on the same side does not exceed –

- (A) 2.5 m in the case of a forward projection, or
- (B) 3.5 m in the case of a rearward projection.

For the purposes of this sub-paragraph the expression the “vehicle” shall not include any special appliance or apparatus or any part thereof which is a forward projection or a rearward projection within the meaning of Article 87;

- (d) the extra side markers required by this sub-paragraph shall also meet the requirements of sub-paragraph (c)(i), (A) and (B);
- (e) every marker fitted in accordance with this paragraph shall be kept clean and unobscured and between sunset and sunrise be illuminated by a lamp which renders it readily visible from a reasonable distance and which is so shielded that its light, except as reflected from the marker, is not visible to other persons using the road.

4 Marking of shorter projections

A projection to which this paragraph applies shall be rendered clearly visible to other persons using the road within a reasonable distance, in the case of a forward projection, from the front thereof or, in the case of a rearward projection from the rear thereof and, in either case, from either side thereof.

5 Marking of wide loads

- (a) Subject to sub-paragraph (d), every load carried on a vehicle in circumstances where this paragraph applies shall be fitted on each side and in the prescribed manner, with –
 - (i) a prescribed marker in such a position that it is visible from the front of the vehicle, and
 - (ii) a prescribed marker in such a position that it is visible from the rear of the vehicle;
- (b) for the purposes of sub-paragraph (a) –
 - (i) a marker on a side of the load is fitted in the prescribed manner if at least part of it is within 50 mm of a longitudinal plane passing through the point on that side of the load which is furthest from the axis of the vehicle, and

- (ii) a prescribed marker is a marker of the size, shape and colour described in Part 2;
- (c) every marker fitted pursuant to this paragraph shall be kept clean and between sunset and sunrise be illuminated by a lamp which renders it readily visible from a reasonable distance and which is so shielded that its light, except as reflected from the marker, is not visible to other persons using the road;
- (d) if the load does not extend beyond the longitudinal plane passing through the extreme projecting point on one side of the vehicle, it shall not be necessary for a marker to be fitted to the load on that side.

PART 2

PROJECTION MARKERS

(Schedule 14, paragraphs 3(a) and 5(b))

Diagram of end marker surface

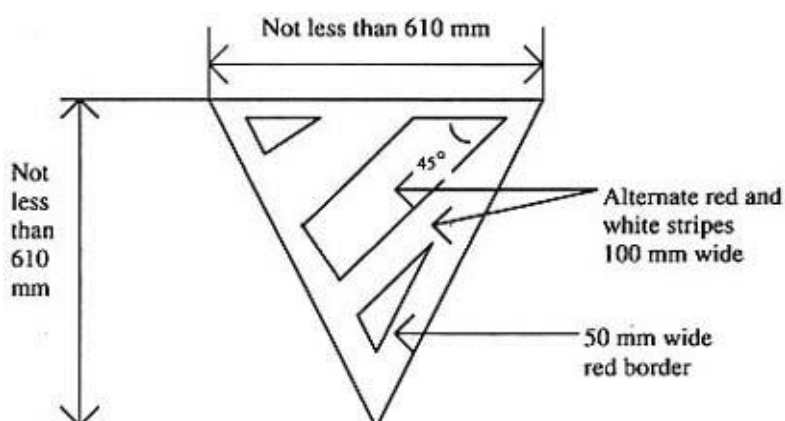
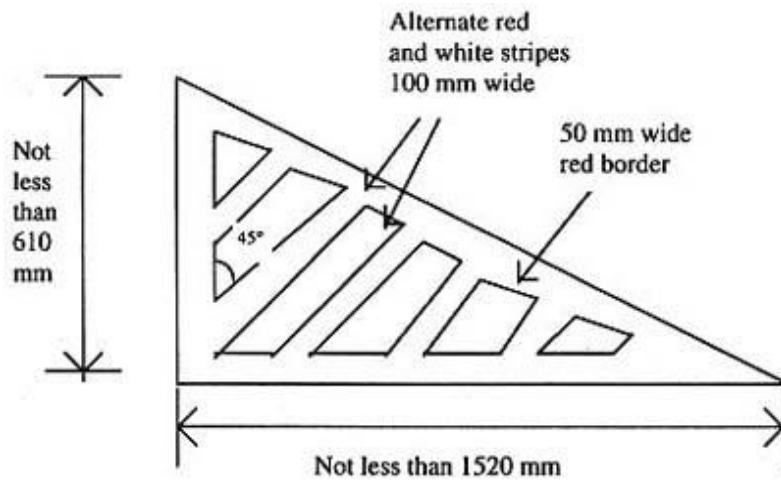

Diagram of side marker surface



SCHEDULE 15

(Article 1(1))

PLATE FOR RESTRICTED SPEED VEHICLE

1. A vehicle displays a plate in accordance with the requirements of this Schedule if a plate in respect of which the following conditions are satisfied is displayed on the vehicle in a prominent position.
2. The conditions are –
 - (a) the plate must be in the form shown in the diagram below;
 - (b) the plate must be at least 150 mm wide and at least 120 mm high;
 - (c) the figures “3” and “0” must be at least 100 mm high and 50 mm wide with a stroke width of at least 12 mm, the figures being black on a white background; and
 - (d) the border must be black and between 3 mm and 5 mm wide.



ENDNOTES

Table of Legislation History

Legislation	Year and No	Commencement
Motor Vehicles (Construction and Use) (Jersey) Order 1998	R&O.9313	1 January 1999
Motor Vehicles (Construction and Use) (Amendment) (Jersey) Order 1999	R&O.9453	1 January 2000
Motor Vehicles (Construction and Use) (Amendment No. 2) (Jersey) Order 2000	R&O.106/2000	1 January 2001
Motor Vehicles (Construction and Use) (Amendment No. 3) (Jersey) Order 2001	R&O.161/2001	1 January 2002
Motor Vehicles (Construction and Use) (Amendment No. 4) (Jersey) Order 2002	R&O.143/2002	1 January 2003
Motor Vehicles (Construction and Use) (Amendment No. 5) (Jersey) Order 2004	R&O.5/2004	2 February 2004
Motor Vehicles (Construction and Use) (Amendment No. 6) (Jersey) Order 2004	R&O.117/2004	1 January 2005
Motor Vehicles (Construction and Use) (Amendment No. 7) (Jersey) Order 2005	R&O.114/2005	1 January 2006
States of Jersey (Amendments and Construction Provisions No. 7) (Jersey) Regulations 2005	R&O.47/2005	9 December 2005
States of Jersey (Amendments and Construction Provisions No. 12) (Jersey) Regulations 2005	R&O.133/2005	9 December 2005
States of Jersey (Transfer of Functions No. 1) (Home Affairs to Transport and Technical Services) (Jersey) Regulations 2006	R&O.41/2006	1 May 2006
Motor Vehicles (Construction and Use) (Amendment No. 8) (Jersey) Order 2007	R&O.17/2007	1 February 2007
Motor Vehicles (Construction and Use) (Amendment No. 9) (Jersey) Order 2007	R&O.124/2007	1 January 2008; annulled by R&O.46/2008 , 1 April 2008
Motor Vehicles (Construction and Use) (Amendment No. 10) (Jersey) Order 2007	R&O.168/2007	1 January 2008

Legislation	Year and No	Commencement
Motor Vehicles (Construction and Use) (Amendment No. 11) (Jersey) Order 2008	R&O.162/2008	1 January 2009
Transport and Technical Services (Driver and Vehicle Standards – 2010 Fees and Miscellaneous Provisions) (Jersey) Order 2009	R&O.141/2009	1 January 2010
Transport and Technical Services (Driver and Vehicle Standards – 2011 Fees) (Jersey) Order 2010	R&O.121/2010	1 January 2011
Transport and Technical Services (Driver and Vehicle Standards – 2012 Fees) (Jersey) Order 2011	R&O.163/2011	1 January 2012
Transport and Technical Services (Driver and Vehicle Standards – 2013 Fees) (Jersey) Order 2012	R&O.134/2012	1 January 2013
Transport and Technical Services (Driver and Vehicle Standards – 2014 Fees) (Jersey) Order 2013	R&O.155/2013	1 January 2014
Transport and Technical Services (Driver and Vehicle Standards – 2015 Fees) (Jersey) Order 2014	R&O.211/2014	1 January 2015
States of Jersey (Transfer of Functions No. 8) (Miscellaneous Transfers) (Jersey) Regulations 2015	R&O.158/2015	1 January 2016
Infrastructure (Driver and Vehicle Standards – 2016 Fees) (Jersey) Order 2015	R&O.167/2015	1 January 2016
Infrastructure (Driver and Vehicle Standards – 2017 Fees) (Jersey) Order 2016	R&O.139/2016	1 January 2017
Infrastructure (Driver and Vehicle Standards – 2018 Fees) (Jersey) Order 2017	R&O.133/2017	1 January 2018
Motor Vehicles (Construction and Use) (Amendment No. 12) (Jersey) Order 2018	R&O.63/2018	14 May 2018
Armed Forces (Vehicles and Roads – Amendments) (Jersey) Regulations 2018	R&O.66/2018	30 June 2018
Infrastructure (Driver and Vehicle Standards – 2019 Fees) (Jersey) Order 2018	R&O.144/2018	1 January 2019
Motor Vehicles (Construction and Use) (Amendment No. 13) (Jersey) Order 2018	R&O.109/2018	14 May 2019

Legislation	Year and No	Commencement
Motor Vehicles (Construction and Use) (Amendment No. 14) (Jersey) Order 2019	R&O.56/2019	12 July 2019
Infrastructure (Driver and Vehicle Standards – 2020 Fees) (Jersey) Order 2019	R&O.142/2019	1 January 2020
Motor Vehicles (Wearing of Seat Belts by Children) (Jersey) Order 2020	R&O.106/2020	17 August 2020
Infrastructure (Driver and Vehicle Standards – 2021 Fees) (Jersey) Order 2020	R&O.174/2020	1 January 2021
Road Traffic (Miscellaneous Amendments – Coastguard Vehicles) (Jersey) Order 2021	R&O.66/2021	17 May 2021
Infrastructure (Driver and Vehicle Standards – 2022 Fees) (Jersey) Order 2021	R&O.165/2021	1 January 2022
Infrastructure (Driver and Vehicle Standards – 2023 Fees) (Jersey) Order 2022	R&O.102/2022	1 January 2023
Motor Vehicles (Registration Fees – Exemption for Zero Emission Vehicles) (Jersey) Order 2023	R&O.17/2023	17 February 2023
Infrastructure (Driver and Vehicle Standards – 2024 Fees) (Jersey) Order 2023	R&O.124/2023	1 January 2024
Infrastructure (Driver and Vehicle Standards – 2025 Fees) (Jersey) Order 2024	R&O.93/2024	1 January 2025

Table of Renumbered Provisions

Original	Current
Part I	Part 1
1(2), (3)	spent, omitted from this revised edition
(4)	1(2)
(5)	(3)
(6)	(4)
(7)	(5)
(8)	(6)
(9)	(7)
(10)	(8)
(11)	(9)
(12)	(10)
(13)	(11)
(14)	(12)

Original	Current
(15)	(13)
Part II	Part 2
Part III	Part 3
Part IV	Part 4
Part V	Part 5
Part VI	Part 6
122	spent, omitted from this revised edition
123	122
Schedule 1, Table I	Schedule 1, Table 1
Schedule 1, Table II	Schedule 1, Table 2
Schedule 3, Part I	Schedule 3, Part 1
Part II	Part 2
Schedule 4, Part I	Schedule 4, Part 1
Part II	Part 2
Schedule 8, Part I	Schedule 8, Part 1
Part II	Part 2
Part III	Part 3
Schedule 9, Part I	Schedule 9, Part 1
Part II	Part 2
Schedule 10, Part I	Schedule 10, Part 1
Part II	Part 2
Part III	Part 3
Schedule 13, Part I	Schedule 13, Part 1
Part II	Part 2
Part III	Part 3
Part IV	Part 4
Part V	Part 5
Part VI	Part 6
Part VII	Part 7
Schedule 14, Part I	Schedule 14, Part 1
Part II	Part 2
Schedule 16	spent, omitted from this revised edition

Table of Endnote References

¹

This Order has been amended by the States of Jersey (Amendments and Construction Provisions No. 7) (Jersey) Regulations 2005 and the States of Jersey (Amendments and Construction Provisions No. 12) (Jersey) Regulations 2005. The amendments replace all references to a Committee of the States of Jersey with a reference to a Minister of the States of Jersey, and remove and add defined terms appropriately, consequentially upon the move from a committee system of government to a ministerial system of government

This Order has been further amended by the States of Jersey (Transfer of Functions No. 1) (Home Affairs to Transport and Technical Services) (Jersey) Regulations 2006. The amendments give effect to the transfer of functions from the Minister for Home Affairs to the Minister for Transport and Technical Services

- ² Article 1(1) *amended by R&O.158/2015, R&O.66/2018*
- ³ Article 1(4) *amended by R&O.66/2018*
- ⁴ Article 2(4) *table amended by R&O.66/2018*
- ⁵ Article 2(7) *substituted by R&O.144/2018, R&O.142/2019, R&O.174/2020, R&O.165/2021, amended by R&O.102/2022, R&O.124/2023, R&O.93/2024*
- ⁶ Article 2(8) *inserted by R&O.66/2018*
- ⁷ Article 2(9) *inserted by R&O.17/2023*
- ⁸ Article 37(5) *amended by R&O.66/2021*
- ⁹ Article 46(1) *revised on 11 January 2024 by Law Revision Board item [2023/2](#)*
- ¹⁰ Article 48(5) *amended by R&O.56/2019*
- ¹¹ Article 49(2) *amended by R&O.56/2019*
- ¹² Article 49(7) *amended by R&O.106/2020*
- ¹³ Article 49(11) *amended by R&O.106/2020*
- ¹⁴ Article 50(1) *amended by R&O.56/2019*
- ¹⁵ Article 52(2) *amended by R&O.66/2018*
- ¹⁶ Article 54(2) *amended by R&O.66/2018*
- ¹⁷ Article 69(2) *revised on 11 January 2024 by Law Revision Board item [2023/2](#)*
- ¹⁸ *these 3 incomplete dates appeared thus in the original version*
- ¹⁹ Article 120(1) *substituted by R&O.63/2018*
- ²⁰ Article 120(1A) *inserted by R&O.63/2018*
- ²¹ Article 120(1B) *inserted by R&O.63/2018, amended by R&O.144/2018, R&O.142/2019, R&O.174/2020, R&O.165/2021, R&O.102/2022, R&O.93/2024*
- ²² Article 120A *inserted by R&O.63/2018*
- ²³ Article 120A *amended by R&O.109/2018*
- ²⁴ Article 120A *amended by R&O.109/2018*
- ²⁵ Article 121(1) *amended by R&O.63/2018, R&O.93/2024*
- ²⁶ Schedule 1 *amended by R&O.56/2019*